



**VILLAGE OF VILLA PARK**

**CONTRACT DOCUMENTS**

**FOR**

**2017 STREET IMPROVEMENTS**

**APRIL 21, 2017**

**PREPARED BY**



Two Pierce Place, Suite 1400  
Itasca, IL 60143  
Phone: 630.773.3900  
Fax: 630.773.3975  
[www.civiltechinc.com](http://www.civiltechinc.com)

**CIVILTECH ENGINEERING, INC.**

**ADVERTISEMENT FOR BIDS  
VILLAGE OF VILLA PARK  
Friday, April 21, 2017**

**PROJECT: 2017 STREET IMPROVEMENTS**

This project consists of various street improvements throughout the Village of Villa Park which includes hot-mix asphalt (HMA) resurfacing and HMA pavement reconstruction. The combined total length of improvements is 8,382.5 feet (1.59 miles). Roadways consisting of pavement resurfacing will have pavement patching and spot curb and gutter replacement based on field conditions. The pavement reconstruction areas (except for Washington Street) will be composed of 2" HMA surface course, 4" HMA binder course and 6" aggregate base course supported on a geotechnical fabric or geogrid. Washington Street will be composed of 2" HMA surface course, 6" HMA binder course and 8" aggregate base course supported on a geotechnical fabric. In addition, there will be sidewalk replacement at intersections to meet the standards of Public Right-of-Way Accessibility Guidelines (PROWAG), driveway reconstruction, drainage and utility improvements, pavement markings, erosion & sediment control, and landscaping.

**BID DEADLINE: TUESDAY, MAY 9, 2017, 10:00 A.M. LOCAL TIME**

The Village reserves the right to extend the Bid Deadline from this date and time to accept Bids submitted after the Bid Deadline, as the Village, in its sole discretion, determines is in the best interest of the Village.

**NOTICE:** Separate, sealed proposals for the **2017 STREET IMPROVEMENTS** project will be received by the Village of Villa Park, Illinois, at the reception desk of the Public Works Department, 11 West Home Avenue, Villa Park, Illinois, 60181, until the Bid Deadline. Immediately thereafter, the proposals will be publicly opened and read aloud at the offices of the Public Works Department. Notwithstanding the foregoing, the Village reserves the right to defer, postpone, delay, or reschedule the Bid Opening for such time and to such date as the Village, in its sole discretion, determines is in the best interest of the Village.

Proposals shall be submitted in accordance with the Bidding Documents prepared by Civiltech Engineering, Inc., 2 Pierce Place, Suite 1400, Itasca, Illinois 60143.

**BIDDER QUALIFICATIONS:** Bidders, in submitting a Bid, shall comply with all applicable Federal, State and local laws and requirements; shall provide documentation of that compliance in accordance with the requirements of the Contract Documents or as requested by the Village; and, in submitting a Bid, Bidders affirm that they are qualified under all applicable laws and requirements to do so, and agree to be bound by the determination of the Village as to Bidder's compliance and qualifications.

**BID SECURITY:** Bid security in the amount of not less than five percent (5%) of the Bid shall accompany each Bid in accordance with the Bidding Documents.

**CONTRACT SECURITY:** The Bidder to whom a Contract is awarded shall be required to furnish both a Performance Bond and a Payment Bond acceptable to the Village for one-hundred percent (100%) of the Contract Price, in accordance with the requirements of the Contract Documents.

**RIGHTS RESERVED:** The Village will select the lowest, most responsible bidder. The Village reserves the right to reject any and all Bids, to waive any informalities or technicalities in bidding, and to accept the Bid which best serves the interests of the Village. The Village shall, in its sole discretion, determine what does or does not constitute an informality or technicality, and, in submitting a Bid, Bidder agrees to be bound by that determination.

The Village may make such investigations as it deems necessary to determine the ability of the Bidder to perform the Work, and the Bidder shall furnish to the Village all such information and data for this purpose as the Village may request. The Village reserves the right to reject any Bid if the evidence submitted by, or investigation of, such Bidder fails to satisfy the Village that such Bidder is properly qualified to carry out the obligations of the Agreement and to complete the Work contemplated therein.

**WAGE RATES:** All applicable laws, ordinances, and the rules and regulations of all authorities having jurisdiction over construction of the PROJECT shall apply to the contract throughout.

**CONTRACT DOCUMENTS:** The Bidding Documents are on file for inspection at the office of the Village of Villa Park Public Works Department, 11 West Home Avenue, Villa Park, Illinois, 60181, and may also be obtained electronically in PDF format on a compact disc from the office listed above for a non-refundable fee of twenty dollars (\$20.00) per compact disc. Payments shall be made in cash or by check made payable to the "Village of Villa Park". A "not-for-bid" version of the bidding documents will also be available on the project page on the Village's website. This version is for informational purposes only, and may not be used for the preparation or submittal of a bid.

**PUBLISHED BY AUTHORITY OF THE VILLAGE OF VILLA PARK, DUPAGE COUNTY, ILLINOIS.**

BY:

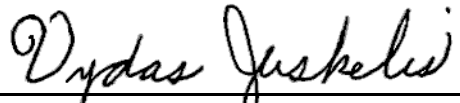
  
Vydas Juskeles, P.E.  
Director of Public Works

Local Public Agency  
Formal Contract Proposal

PROPOSAL SUBMITTED BY		
Contractor's Name		
Street	P.O.Box	
City	State	Zip Code

STATE OF ILLINOIS

COUNTY OF DUPAGE  
VILLAGE OF VILLA PARK  
 (Name of City, Village, Town or Road District)

FOR THE IMPROVEMENT OF

PROJECT NAME 2017 STREET IMPROVEMENTS  
 SECTION NO. N.A.  
 TYPES OF FUNDS LOCAL FUNDING

SPECIFICATIONS (required)

PLANS (required)

NOT FOR BID

**Note:** All proposal documents, including Proposal Guaranty Checks or Proposal Bid Bonds, should be stapled together to prevent loss when bids are processed.

RETURN WITH BID

NOTICE TO BIDDERS

County DUPAGE
Local Public Agency VILLAGE OF VILLA PARK
Section Number N.A.
Route VARIOUS

Sealed proposals for the improvement described below will be received at the office of Villa Park Public Works Department
11 West Home Avenue, Villa Park, IL 60181 until 10:00 AM on 05/09/2017

Sealed proposals will be opened and read publicly at the office of Villa Park Public Works Department
11 West Home Avenue, Villa Park, IL 60181 at 10:00 AM on 05/09/2017

DESCRIPTION OF WORK

Name 2017 Street Improvements Length: 8,382.5 feet ( 1.59 miles)
Location Various improvements throughout the Village of Villa Park
Proposed Improvement Various improvement methods consisting of HMA resurfacing, HMA reconstruction, pavement patching, curb and gutter replacement, HMA & PCC driveway reconstruction, and some utility improvements.

1. Plans and proposal forms will be available in the office of Villa Park Public Works Department in PDF format on a compact disc at a cost of \$20 per compact disc. 11 West Home Avenue, Villa Park, IL 60181 (630) 834-8505

2. [ ] Prequalification

If checked, the 2 low bidders must file within 24 hours after the letting an "Affidavit of Availability" (Form BC 57), in duplicate, showing all uncompleted contracts awarded to them and all low bids pending award for Federal, State, County, Municipal and private work. One original shall be filed with the Awarding Authority.

3. The Awarding Authority reserves the right to waive technicalities and to reject any or all proposals as provided in BLRS Special Provision for Bidding Requirements and Conditions for Contract Proposals.

4. The following BLR Forms shall be returned by the bidder to the Awarding Authority:

- a. BLR 12200: Local Public Agency Formal Contract Proposal
b. BLR 12200a Schedule of Prices
c. BLR 12230: Proposal Bid Bond (if applicable)
d. BLR 12325: Apprenticeship or Training Program Certification (do not use for federally funded projects)
e. BLR 12326: Affidavit of Illinois Business Office

5. The quantities appearing in the bid schedule are approximate and are prepared for the comparison of bids. Payment to the Contractor will be made only for the actual quantities of work performed and accepted or materials furnished according to the contract. The scheduled quantities of work to be done and materials to be furnished may be increased, decreased or omitted as hereinafter provided.

6. Submission of a bid shall be conclusive assurance and warranty the bidder has examined the plans and understands all requirements for the performance of work. The bidder will be responsible for all errors in the proposal resulting from failure or neglect to conduct an in depth examination. The Awarding Authority will, in no case be responsible for any costs, expenses, losses or changes in anticipated profits resulting from such failure or neglect of the bidder.

7. The bidder shall take no advantage of any error or omission in the proposal and advertised contract.

8. If a special envelope is supplied by the Awarding Authority, each proposal should be submitted in that envelope furnished by the Awarding Agency and the blank spaces on the envelope shall be filled in correctly to clearly indicate its contents. When an envelope other than the special one furnished by the Awarding Authority is used, it shall be marked to clearly indicate its contents. When sent by mail, the sealed proposal shall be addressed to the Awarding Authority at the address and in care of the official in whose office the bids are to be received. All proposals shall be filed prior to the time and at the place specified in the Notice to Bidders. Proposals received after the time specified will be returned to the bidder unopened.

9. Permission will be given to a bidder to withdraw a proposal if the bidder makes the request in writing or in person before the time for opening proposals.

RETURN WITH BID

PROPOSAL

County DUPAGE
Local Public Agency VILLAGE OF VILLA PARK
Section Number N.A.
Route VARIOUS

- 1. Proposal of ... for the improvement of the above section by the construction of Pavement resurfacing with HMA surface course and leveling binder, pavement reconstruction with HMA surface course, HMA binder course, and aggregate base supported by geotechnical fabric or geogrid, reconstruction of HMA & PCC driveways, replacement of combination concrete curb and gutter, pavement patching, some utility work, and all other work shown in the plans and described in contract documents.
2. The plans for the proposed work are those prepared by Civiltech Engineering, Inc. 2 Pierce Place, Suite 1400, Itasca, IL 60143 and approved by the Village of Villa Park on April 21, 2017
3. The specifications referred to herein are those prepared by the Department of Transportation and designated as "Standard Specifications for Road and Bridge Construction" and the "Supplemental Specifications and Recurring Special Provisions" thereto, adopted and in effect on the date of invitation for bids.
4. The undersigned agrees to accept, as part of the contract, the applicable Special Provisions indicated on the "Check Sheet for Recurring Special Provisions" contained in this proposal.
5. The undersigned agrees to complete the work within the contract time provided by the special provision, "Completion of Project" unless additional time is granted in accordance with the specifications.
6. A proposal guaranty in the proper amount, as specified in BLRS Special Provision for Bidding Requirements and Conditions for Contract Proposals, will be required. Bid Bonds will be allowed as a proposal guaranty. Accompanying this proposal is either a bid bond if allowed, on Department form BLR 12230 or a proposal guaranty check, complying with the specifications, made payable to: Village Treasurer of the Village of Villa Park
The amount of the check is 5% of Bid = ( ).
7. In the event that one proposal guaranty check is intended to cover two or more proposals, the amount must be equal to the sum of the proposal guaranties, which would be required for each individual proposal. If the proposal guaranty check is placed in another proposal, it will be found in the proposal for: Section Number Not Applicable
8. The successful bidder at the time of execution of the contract will be required to deposit a contract bond for the full amount of the award. When a contract bond is not required, the proposal guaranty check will be held in lieu thereof. If this proposal is accepted and the undersigned fails to execute a contract and contract bond as required, it is hereby agreed that the Bid Bond or check shall be forfeited to the Awarding Authority.
9. Each pay item should have a unit price and a total price. If no total price is shown or if there is a discrepancy between the product of the unit price multiplied by the quantity, the unit price shall govern. If a unit price is omitted, the total price will be divided by the quantity in order to establish a unit price.
10. A bid will be declared unacceptable if neither a unit price nor a total price is shown.
11. The undersigned submits herewith the schedule of prices on BLR 12200a covering the work to be performed under this contract.
12. The undersigned further agrees that if awarded the contract for the sections contained in the combinations on BLR 12200a, the work shall be in accordance with the requirements of each individual proposal for the multiple bid specified in the Schedule for Multiple Bids below.

**SCHEDULE OF PRICES**

County DUPAGE  
 Local Public Agency VILLAGE OF VILLA PARK  
 Section N.A.  
 Route VARIOUS

**Schedule for BASE BID**

(For complete information covering these items, see plans and specifications)

Item No.	Items	Unit	Quantity	Unit Price	Total
1	TEMPORARY FENCE	FOOT	3,040		
2	TREE ROOT PRUNING	EACH	124		
3	EARTH EXCAVATION	CU YD	4,560		
4	REMOVAL AND DISPOSAL OF UNSUITABLE MATERIAL	CU YD	713		
5	TRENCH BACKFILL	CU YD	300		
6	GEOTECHNICAL FABRIC FOR GROUND STABILIZATION	SQ YD	16,397		
7	SUPPLEMENTAL WATERING	UNIT	90		
8	PERIMETER EROSION BARRIER	FOOT	134		
9	INLET FILTERS	EACH	60		
10	AGGREGATE SUBGRADE IMPROVEMENT	CU YD	150		
11	AGGREGATE SUBGRADE IMPROVEMENT 12"	SQ YD	1,206		
12	AGGREGATE BASE COURSE, TYPE B	CU YD	112		
13	AGGREGATE BASE COURSE, TYPE B 6"	SQ YD	14,104		
14	AGGREGATE BASE COURSE, TYPE B 8"	SQ YD	1,300		
15	PREPARATION OF BASE	SQ YD	824		

RETURN WITH BID

Item No.	Items	Unit	Quantity	Unit Price	Total
16	AGGREGATE BASE REPAIR	TON	165		
17	BITUMINOUS MATERIALS (TACK COAT)	POUND	12,450		
18	LEVELING BINDER (MACHINE METHOD), N50	TON	358		
19	HOT-MIX ASPHALT SURFACE REMOVAL - BUTT JOINT	SQ YD	228		
20	PORTLAND CEMENT CONCRETE SURFACE REMOVAL - BUTT JOINT	SQ YD	71		
21	TEMPORARY RAMP	SQ YD	97		
22	HOT-MIX ASPHALT BINDER COURSE, IL-19.0, N50	TON	3,845		
23	HOT-MIX ASPHALT SURFACE COURSE, MIX "D", N50	TON	2,666		
24	PROTECTIVE COAT	SQ YD	5,472		
25	DETECTABLE WARNINGS	SQ FT	630		
26	DRIVEWAY PAVEMENT REMOVAL	SQ YD	3,143		
27	COMBINATION CURB AND GUTTER REMOVAL	FOOT	9,494		
28	SIDEWALK REMOVAL	SQ FT	9,007		
29	CLASS C PATCHES, 6 INCH	SQ YD	726		
30	CLASS D PATCHES, 6 INCH	SQ YD	272		
31	AGGREGATE SHOULDERS, TYPE B 6"	SQ YD	161		
32	STORM SEWERS, CLASS A, 12"	FOOT	76		
33	STORM SEWERS, CLASS A, 36"	FOOT	155		
34	STORM SEWERS, RUBBER GASKET, CLASS A, TYPE 2 36"	FOOT	151		
35	STORM SEWERS, CLASS B, 8"	FOOT	20		
36	STORM SEWERS, CLASS B, 10"	FOOT	31		
37	FIRE HYDRANTS TO BE MOVED (SPECIAL)	EACH	0	--	\$0.00
38	FIRE HYDRANT WITH AUXILIARY VALVE AND VALVE BOX	EACH	3		

**RETURN WITH BID**

Item No.	Items	Unit	Quantity	Unit Price	Total
39	CATCH BASINS, TYPE A, 4'-DIAMETER, TYPE 11 FRAME AND GRATE	EACH	7		
40	CATCH BASINS, TYPE C, TYPE 11 FRAME AND GRATE	EACH	3		
41	MANHOLES, TYPE A, 4'-DIAMETER, TYPE 1 FRAME, CLOSED LID	EACH	5		
42	MANHOLES, TYPE A, 6'-DIAMETER, TYPE 1 FRAME, CLOSED LID	EACH	1		
43	MANHOLES, TYPE A, 6'-DIAMETER, TYPE 11 FRAME AND GRATE	EACH	1		
44	MANHOLES, TYPE A, 7'-DIAMETER, TYPE 1 FRAME, CLOSED LID	EACH	2		
45	INLETS, TYPE A, TYPE 11 FRAME AND GRATE	EACH	7		
46	VALVE VAULTS, TYPE A, 4'-DIAMETER, TYPE 1 FRAME, CLOSED LID	EACH	1		
47	FRAMES AND GRATES, TYPE 11	EACH	18		
48	FRAMES AND LIDS, TYPE 1	EACH	9		
49	GUARDRAIL REMOVAL	FOOT	0	--	\$0.00
50	NON-SPECIAL WASTE DISPOSAL	CU YD	258		
51	REMOVE SIGN PANEL ASSEMBLY - TYPE A	EACH	0	--	\$0.00
52	RELOCATE SIGN PANEL ASSEMBLY - TYPE A	EACH	4		
53	TELESCOPING STEEL SIGN SUPPORT	FOOT	60		
54	THERMOPLASTIC PAVEMENT MARKING - LINE 4"	FOOT	765		
55	THERMOPLASTIC PAVEMENT MARKING - LINE 6"	FOOT	52		
56	THERMOPLASTIC PAVEMENT MARKING - LINE 24"	FOOT	227		
57	HOT-MIX ASPHALT DRIVEWAY PAVEMENT, 4"	SQ YD	582		
58	HOT-MIX ASPHALT DRIVEWAY PAVEMENT, 6"	SQ YD	150		
59	CONSTRUCTION LAYOUT	L SUM	1		
60	DRAINAGE & UTILITY STRUCTURES TO BE ADJUSTED	EACH	47		
61	DRAINAGE & UTILITY STRUCTURES TO BE RECONSTRUCTED	EACH	24		

**RETURN WITH BID**

Item No.	Items	Unit	Quantity	Unit Price	Total
62	STORM SEWER (WATER MAIN REQUIREMENTS) 10 INCH	FOOT	57		
63	STORM SEWER (WATER MAIN REQUIREMENTS) 12 INCH	FOOT	33		
64	SAWING P.C. CONCRETE PAVEMENT (FULL DEPTH)	FOOT	4,137		
65	TOPSOIL FURNISH AND PLACE, 4" (SPECIAL)	SQ YD	9,628		
66	EXPLORATION TRENCH, SPECIAL	FOOT	300		
67	SODDING, SPECIAL	SQ YD	9,628		
68	TEMPORARY ACCESS (DRIVEWAY ENTRANCE)	EACH	15		
69	TEMPORARY ACCESS (ROAD)	EACH	19		
70	PORTLAND CEMENT CONCRETE DRIVEWAY PAVEMENT, 6 INCH, SPECIAL	SQ YD	1,357		
71	PORTLAND CEMENT CONCRETE DRIVEWAY PAVEMENT, 8 INCH, SPECIAL	SQ YD	1,122		
72	PORTLAND CEMENT CONCRETE SIDEWALK 5 INCH, SPECIAL	SQ FT	8,557		
73	PORTLAND CEMENT CONCRETE SIDEWALK 8 INCH, SPECIAL	SQ FT	1,308		
74	PORTLAND CEMENT CONCRETE SURFACE REMOVAL (VARIABLE DEPTH)	SQ YD	5,503		
75	HOT-MIX ASPHALT SURFACE REMOVAL, VARIABLE DEPTH	SQ YD	2,996		
76	PAVEMENT REMOVAL (SPECIAL)	SQ YD	16,340		
77	VALVE BOXES TO BE ADJUSTED (SPECIAL)	EACH	3		
78	CONCRETE CURB (SPECIAL)	FOOT	149		
79	COMBINATION CONCRETE CURB AND GUTTER, TYPE B-6.12 (SPECIAL)	FOOT	11,067		
80	TRAFFIC CONTROL AND PROTECTION, (SPECIAL)	L SUM	1		
81	CONNECTION TO EXISTING WATER MAIN (NON PRESSURE)	EACH	3		
82	PRECONSTRUCTION VIDEO TAPING	L SUM	1		
83	SANITARY SEWER CLEAN OUT	EACH	4		
84	AND REPLACE, 6-INCH DIAMETER OR LESS	FOOT	80		

**RETURN WITH BID**

Item No.	Items	Unit	Quantity	Unit Price	Total
85	SANITARY SEWER REPAIR, REMOVE AND REPLACE, OVER 6-INCH DIAMETER	FOOT	35		
86	SANITARY MANHOLES, 4'-DIAMETER, TYPE 1 FRAME, CLOSED LID	EACH	1		
87	GEOGRID	SQ YD	1,206		
88	REMOVE DECORATIVE STONE	EACH	2		
89	WATER USAGE DEDUCTION	T GAL	100	-\$8.85	-\$885.00
90	WATER USAGE CREDIT	T GAL	100	\$8.85	\$885.00
91	CONTINGENCY ALLOWANCE	UNIT	30,000	\$1.00	\$30,000.00

<b>Bidder's Proposal for making Entire Improvements:</b>
--

(TOTAL BID)

**THE SELECTION OF LOW BIDDER WILL BE BASED ON EITHER THE BASE BID OR THE BASE & ALTERNATE BID AS DETERMINED BY THE VILLAGE**

NOT FOR BID

**SCHEDULE OF PRICES**

County DUPAGE  
 Local Public Agency VILLAGE OF VILLA PARK  
 Section N.A.  
 Route VARIOUS

**Schedule for BASE & ALTERNATE BID**

(For complete information covering these items, see plans and specifications)

Item No.	Items	Unit	Quantity	Unit Price	Total
1	TEMPORARY FENCE	FOOT	3,100		
2	TREE ROOT PRUNING	EACH	125		
3	EARTH EXCAVATION	CU YD	4,865		
4	REMOVAL AND DISPOSAL OF UNSUITABLE MATERIAL	CU YD	1,118		
5	TRENCH BACKFILL	CU YD	300		
6	GEOTECHNICAL FABRIC FOR GROUND STABILIZATION	SQ YD	17,015		
7	SUPPLEMENTAL WATERING	UNIT	97		
8	PERIMETER EROSION BARRIER	FOOT	193		
9	INLET FILTERS	EACH	60		
10	AGGREGATE SUBGRADE IMPROVEMENT	CU YD	250		
11	AGGREGATE SUBGRADE IMPROVEMENT 12"	SQ YD	1,206		
12	AGGREGATE BASE COURSE, TYPE B	CU YD	212		
13	AGGREGATE BASE COURSE, TYPE B 6"	SQ YD	14,681		
14	AGGREGATE BASE COURSE, TYPE B 8"	SQ YD	1,300		
15	PREPARATION OF BASE	SQ YD	824		

RETURN WITH BID

Item No.	Items	Unit	Quantity	Unit Price	Total
16	AGGREGATE BASE REPAIR	TON	165		
17	BITUMINOUS MATERIALS (TACK COAT)	POUND	12,580		
18	LEVELING BINDER (MACHINE METHOD), N50	TON	358		
19	HOT-MIX ASPHALT SURFACE REMOVAL - BUTT JOINT	SQ YD	269		
20	PORTLAND CEMENT CONCRETE SURFACE REMOVAL - BUTT JOINT	SQ YD	71		
21	TEMPORARY RAMP	SQ YD	97		
22	HOT-MIX ASPHALT BINDER COURSE, IL-19.0, N50	TON	3,975		
23	HOT-MIX ASPHALT SURFACE COURSE, MIX "D", N50	TON	2,735		
24	PROTECTIVE COAT	SQ YD	5,614		
25	DETECTABLE WARNINGS	SQ FT	660		
26	DRIVEWAY PAVEMENT REMOVAL	SQ YD	3,196		
27	COMBINATION CURB AND GUTTER REMOVAL	FOOT	9,516		
28	SIDEWALK REMOVAL	SQ FT	9,377		
29	CLASS C PATCHES, 6 INCH	SQ YD	726		
30	CLASS D PATCHES, 6 INCH	SQ YD	272		
31	AGGREGATE SHOULDERS, TYPE B 6"	SQ YD	214		
32	STORM SEWERS, CLASS A, 12"	FOOT	76		
33	STORM SEWERS, CLASS A, 36"	FOOT	155		
34	STORM SEWERS, RUBBER GASKET, CLASS A, TYPE 2 36"	FOOT	151		
35	STORM SEWERS, CLASS B, 8"	FOOT	20		
36	STORM SEWERS, CLASS B, 10"	FOOT	31		
37	FIRE HYDRANTS TO BE MOVED (SPECIAL)	EACH	1		
38	FIRE HYDRANT WITH AUXILIARY VALVE AND VALVE BOX	EACH	3		

**RETURN WITH BID**

Item No.	Items	Unit	Quantity	Unit Price	Total
39	CATCH BASINS, TYPE A, 4'-DIAMETER, TYPE 11 FRAME AND GRATE	EACH	7		
40	CATCH BASINS, TYPE C, TYPE 11 FRAME AND GRATE	EACH	3		
41	MANHOLES, TYPE A, 4'-DIAMETER, TYPE 1 FRAME, CLOSED LID	EACH	5		
42	MANHOLES, TYPE A, 6'-DIAMETER, TYPE 1 FRAME, CLOSED LID	EACH	1		
43	MANHOLES, TYPE A, 6'-DIAMETER, TYPE 11 FRAME AND GRATE	EACH	1		
44	MANHOLES, TYPE A, 7'-DIAMETER, TYPE 1 FRAME, CLOSED LID	EACH	2		
45	INLETS, TYPE A, TYPE 11 FRAME AND GRATE	EACH	7		
46	VALVE VAULTS, TYPE A, 4'-DIAMETER, TYPE 1 FRAME, CLOSED LID	EACH	1		
47	FRAMES AND GRATES, TYPE 11	EACH	18		
48	FRAMES AND LIDS, TYPE 1	EACH	10		
49	GUARDRAIL REMOVAL	FOOT	34		
50	NON-SPECIAL WASTE DISPOSAL	CU YD	358		
51	REMOVE SIGN PANEL ASSEMBLY - TYPE A	EACH	1		
52	RELOCATE SIGN PANEL ASSEMBLY - TYPE A	EACH	4		
53	TELESCOPING STEEL SIGN SUPPORT	FOOT	60		
54	THERMOPLASTIC PAVEMENT MARKING - LINE 4"	FOOT	765		
55	THERMOPLASTIC PAVEMENT MARKING - LINE 6"	FOOT	52		
56	THERMOPLASTIC PAVEMENT MARKING - LINE 24"	FOOT	237		
57	HOT-MIX ASPHALT DRIVEWAY PAVEMENT, 4"	SQ YD	635		
58	HOT-MIX ASPHALT DRIVEWAY PAVEMENT, 6"	SQ YD	150		
59	CONSTRUCTION LAYOUT	L SUM	1		
60	DRAINAGE & UTILITY STRUCTURES TO BE ADJUSTED	EACH	47		
61	DRAINAGE & UTILITY STRUCTURES TO BE RECONSTRUCTED	EACH	28		

**RETURN WITH BID**

Item No.	Items	Unit	Quantity	Unit Price	Total
62	STORM SEWER (WATER MAIN REQUIREMENTS) 10 INCH	FOOT	57		
63	STORM SEWER (WATER MAIN REQUIREMENTS) 12 INCH	FOOT	33		
64	SAWING P.C. CONCRETE PAVEMENT (FULL DEPTH)	FOOT	4,137		
65	TOPSOIL FURNISH AND PLACE, 4" (SPECIAL)	SQ YD	10,364		
66	EXPLORATION TRENCH, SPECIAL	FOOT	350		
67	SODDING, SPECIAL	SQ YD	10,364		
68	TEMPORARY ACCESS (DRIVEWAY ENTRANCE)	EACH	15		
69	TEMPORARY ACCESS (ROAD)	EACH	19		
70	PORTLAND CEMENT CONCRETE DRIVEWAY PAVEMENT, 6 INCH, SPECIAL	SQ YD	1,357		
71	PORTLAND CEMENT CONCRETE DRIVEWAY PAVEMENT, 8 INCH, SPECIAL	SQ YD	1,122		
72	PORTLAND CEMENT CONCRETE SIDEWALK 5 INCH, SPECIAL	SQ FT	9,554		
73	PORTLAND CEMENT CONCRETE SIDEWALK 8 INCH, SPECIAL	SQ FT	1,308		
74	PORTLAND CEMENT CONCRETE SURFACE REMOVAL (VARIABLE DEPTH)	SQ YD	5,503		
75	HOT-MIX ASPHALT SURFACE REMOVAL, VARIABLE DEPTH	SQ YD	2,996		
76	PAVEMENT REMOVAL (SPECIAL)	SQ YD	16,366		
77	VALVE BOXES TO BE ADJUSTED (SPECIAL)	EACH	3		
78	CONCRETE CURB (SPECIAL)	FOOT	149		
79	COMBINATION CONCRETE CURB AND GUTTER, TYPE B-6.12 (SPECIAL)	FOOT	11,242		
80	TRAFFIC CONTROL AND PROTECTION, (SPECIAL)	L SUM	1		
81	CONNECTION TO EXISTING WATER MAIN (NON PRESSURE)	EACH	3		
82	PRECONSTRUCTION VIDEO TAPING	L SUM	1		
83	SANITARY SEWER CLEAN OUT	EACH	4		
84	AND REPLACE, 6-INCH DIAMETER OR LESS	FOOT	80		

**RETURN WITH BID**

Item No.	Items	Unit	Quantity	Unit Price	Total
85	SANITARY SEWER REPAIR, REMOVE AND REPLACE, OVER 6-INCH DIAMETER	FOOT	35		
86	SANITARY MANHOLES, 4'-DIAMETER, TYPE 1 FRAME, CLOSED LID	EACH	1		
87	GEOGRID	SQ YD	1,206		
88	REMOVE DECORATIVE STONE	EACH	2		
89	WATER USAGE DEDUCTION	T GAL	100	-\$8.85	-\$885.00
90	WATER USAGE CREDIT	T GAL	100	\$8.85	\$885.00
91	CONTINGENCY ALLOWANCE	UNIT	30,000	\$1.00	\$30,000.00

<b>Bidder's Proposal for making Entire Improvements:</b>
--

(TOTAL BID)

**THE SELECTION OF LOW BIDDER WILL BE BASED ON EITHER THE BASE BID OR THE BASE & ALTERNATE BID AS DETERMINED BY THE VILLAGE**

NOT FOR BID

CONTRACTOR CERTIFICATIONS

County	<u>DUPAGE</u>
Local Public Agency	<u>VILLAGE OF VILLA PARK</u>
Section Number	<u>N.A.</u>
Route	<u>VARIOUS</u>

The certifications hereinafter made by the bidder are each a material representation of fact upon which reliance is placed should the Department enter into the contract with the bidder.

1. **Debt Delinquency.** The bidder or contractor or subcontractor, respectively, certifies that it is not delinquent in the payment of any tax administered by the Department of Revenue unless the individual or other entity is contesting, in accordance with the procedures established by the appropriate revenue Act, its liability for the tax or the amount of tax. Making a false statement voids the contract and allows the Department to recover all amounts paid to the individual or entity under the contract in a civil action.

2. **Bid-Rigging or Bid Rotating.** The bidder or contractor or subcontractor, respectively, certifies that it is not barred from contracting with the Department by reason of a violation of either 720 ILCS 5/33E-3 or 720 ILCS 5/33E-4.

A violation of Section 33E-3 would be represented by a conviction of the crime of bid-rigging which, in addition to Class 3 felony sentencing, provides that any person convicted of this offense or any similar offense of any state or the United States which contains the same elements as this offense shall be barred for 5 years from the date of conviction from contracting with any unit of State or local government. No corporation shall be barred from contracting with any unit of State or local government as a result of a conviction under this Section of any employee or agent of such corporation if the employee so convicted is no longer employed by the corporation and: (1) it has been finally adjudicated not guilty or (2) if it demonstrates to the governmental entity with which it seeks to contract and that entity finds that the commission of the offense was neither authorized, requested, commanded, nor performed by a director, officer or a high managerial agent in behalf of the corporation.

A violation of Section 33E-4 would be represented by a conviction of the crime of bid-rotating which, in addition to Class 2 felony sentencing, provides that any person convicted of this offense or any similar offense of any state or the United States which contains the same elements as this offense shall be permanently barred from contracting with any unit of State or local government. No corporation shall be barred from contracting with any unit of State or local government as a result of a conviction under this Section of any employee or agent of such corporation if the employee so convicted is no longer employed by the corporation and: (1) it has been finally adjudicated not guilty or (2) if it demonstrates to the governmental entity with which it seeks to contract and that entity finds that the commission of the offense was neither authorized, requested, commanded, nor performed by a director, officer or a high managerial agent in behalf of the corporation.

3. **Bribery.** The bidder or contractor or subcontractor, respectively, certifies that it has not been convicted of bribery or attempting to bribe an officer or employee of the State of Illinois or any unit of local government, nor has the firm made an admission of guilt of such conduct which is a matter of record, nor has an official, agent, or employee of the firm committed bribery or attempted bribery on behalf of the firm and pursuant to the direction or authorization of a responsible official of the firm.

4. **Interim Suspension or Suspension.** The bidder or contractor or subcontractor, respectively, certifies that it is not currently under a suspension as defined in Subpart I of Title 44 Subtitle A Chapter III Part 6 of the Illinois Administrative Code. Furthermore, if suspended prior to completion of this work, the contract or contracts executed for the completion of this work may be cancelled.

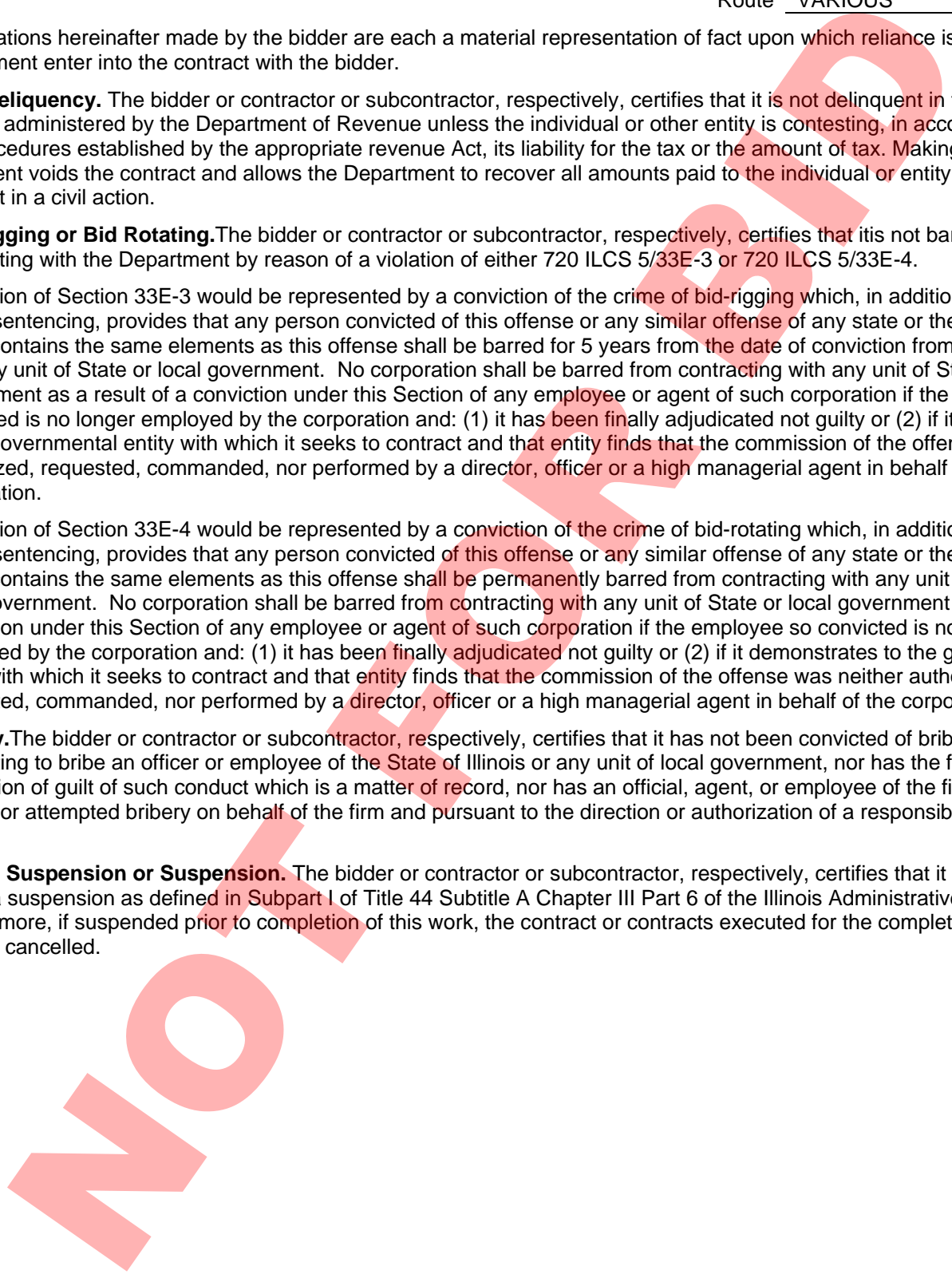

RETURN WITH BID

SIGNATURES

County DUPAGE  
Local Public Agency VILLAGE OF VILLA PARK  
Section Number N.A.  
Route VARIOUS

(If an individual)

Signature of Bidder \_\_\_\_\_

Business Address \_\_\_\_\_  
\_\_\_\_\_

(If a partnership)

Firm Name \_\_\_\_\_

Signed By \_\_\_\_\_

Business Address \_\_\_\_\_  
\_\_\_\_\_

Inset Names and Addressed of All Partners



(If a corporation)

Corporate Name \_\_\_\_\_

Signed By \_\_\_\_\_

President

Business Address \_\_\_\_\_  
\_\_\_\_\_

Inset Names of Officers



President \_\_\_\_\_

Secretary \_\_\_\_\_

Treasurer \_\_\_\_\_

Attest: \_\_\_\_\_  
Secretary

**Local Agency  
Proposal Bid Bond**

Route VARIOUS  
County DUPAGE  
Local Agency VILLAGE OF VILLA PARK  
Section N.A.

**RETURN WITH BID**

**PAPER BID BOND**

WE \_\_\_\_\_ as PRINCIPAL,  
and \_\_\_\_\_ as SURETY,  
are held jointly, severally and firmly bound unto the above Local Agency (hereafter referred to as "LA") in the penal sum of 5% of the total bid price, or for the amount specified in the proposal documents in effect on the date of invitation for bids whichever is the lesser sum. We bind ourselves, our heirs, executors, administrators, successors, and assigns, jointly pay to the LA this sum under the conditions of this instrument.

WHEREAS THE CONDITION OF THE FOREGOING OBLIGATION IS SUCH that, the said PRINCIPAL is submitting a written proposal to the LA acting through its awarding authority for the construction of the work designated as the above section.

THEREFORE if the proposal is accepted and a contract awarded to the PRINCIPAL by the LA for the above designated section and the PRINCIPAL shall within fifteen (15) days after award enter into a formal contract, furnish surety guaranteeing the faithful performance of the work, and furnish evidence of the required insurance coverage, all as provided in the "Standard Specifications for Road and Bridge Construction" and applicable Supplemental Specifications, then this obligation shall become void; otherwise it shall remain in full force and effect.

IN THE EVENT the LA determines the PRINCIPAL has failed to enter into a formal contract in compliance with any requirements set forth in the preceding paragraph, then the LA acting through its awarding authority shall immediately be entitled to recover the full penal sum set out above, together with all court costs, all attorney fees, and any other expense of recovery.

IN TESTIMONY WHEREOF, the said PRINCIPAL and the said SURETY have caused this instrument to be signed by their respective officers this \_\_\_\_\_ day of \_\_\_\_\_

**Principal**

\_\_\_\_\_  
(Company Name) \_\_\_\_\_ (Company Name)  
By: \_\_\_\_\_ By: \_\_\_\_\_  
(Signature and Title) (Signature and Title)

(If PRINCIPLE is a joint venture of two or more contractors, the company names, and authorized signatures of each contractor must be affixed.)

**Surety**

\_\_\_\_\_  
(Name of Surety) By: \_\_\_\_\_  
(Signature of Attorney-in-Fact)

STATE OF ILLINOIS,  
COUNTY OF \_\_\_\_\_  
I, \_\_\_\_\_, a Notary Public in and for said county,  
do hereby certify that \_\_\_\_\_

(Insert names of individuals signing on behalf of PRINCIPAL & SURETY)

who are each personally known to me to be the same persons whose names are subscribed to the foregoing instrument on behalf of PRINCIPAL and SURETY, appeared before me this day in person and acknowledged respectively, that they signed and delivered said instruments as their free and voluntary act for the uses and purposes therein set forth.

Given under my hand and notarial seal this \_\_\_\_\_ day of \_\_\_\_\_

My commission expires \_\_\_\_\_  
(Notary Public)

**ELECTRONIC BID BOND**

**Electronic bid bond is allowed (box must be checked by LA if electronic bid bond is allowed)**

The Principal may submit an electronic bid bond, in lieu of completing the above section of the Proposal Bid Bond Form. By providing an electronic bid bond ID code and signing below, the Principal is ensuring the identified electronic bid bond has been executed and the Principal and Surety are firmly bound unto the LA under the conditions of the bid bond as shown above. (If PRINCIPAL is a joint venture of two or more contractors, an electronic bid bond ID code, company/Bidder name title and date must be affixed for each contractor in the venture.)

\_\_\_\_\_  
Electronic Bid Bond ID Code

\_\_\_\_\_  
(Company/Bidder Name)

\_\_\_\_\_  
(Signature and Title)

\_\_\_\_\_  
Date

**Apprenticeship or Training  
Program Certification**

**Return with Bid**

Route VARIOUS  
County DUPAGE  
Local Agency VILLAGE OF VILLA PARK  
Section N.A.

**All contractors are required to complete the following certification:**

- For this contract proposal or for all groups in this deliver and install proposal.
- For the following deliver and install groups in this material proposal:

---

---

---

---

Illinois Department of Transportation policy, adopted in accordance with the provisions of the Illinois Highway Code, requires this contract to be awarded to the lowest responsive and responsible bidder. The award decision is subject to approval by the Department. In addition to all other responsibility factors, this contract or deliver and install proposal requires all bidders and all bidders' subcontractors to disclose participation in apprenticeship or training programs that are (1) approved by and registered with the United States Department of Labor's Bureau of Apprenticeship and Training, and (2) applicable to the work of the above indicated proposals or groups. Therefore, all bidders are required to complete the following certification:

- I. Except as provided in paragraph IV below, the undersigned bidder certifies that it is a participant, either as an individual or as part of a group program, in an approved apprenticeship or training program applicable to each type of work or craft that the bidder will perform with its own employees.
- II. The undersigned bidder further certifies for work to be performed by subcontract that each of its subcontractors submitted for approval either (A) is, at the time of such bid, participating in an approved, applicable apprenticeship or training program; or (B) will, prior to commencement of performance of work pursuant to this contract, establish participation in an approved apprenticeship or training program applicable to the work of the subcontract.
- III. The undersigned bidder, by inclusion in the list in the space below, certifies the official name of each program sponsor holding the Certificate of Registration for all of the types of work or crafts in which the bidder is a participant and that will be performed with the bidder's employees. Types of work or craft that will be subcontracted shall be included and listed as subcontract work. The list shall also indicate any type of work or craft job category for which there is no applicable apprenticeship or training program available.

---

---

---

---

IV. Except for any work identified above, any bidder or subcontractor that shall perform all or part of the work of the contract or deliver and install proposal solely by individual owners, partners or members and not by employees to whom the payment of prevailing rates of wages would be required, check the following box, and identify the owner/operator workforce and positions of ownership.

---

---

---

---

The requirements of this certification and disclosure are a material part of the contract, and the contractor shall require this certification provision to be included in all approved subcontracts. The bidder is responsible for making a complete report and shall make certain that each type of work or craft job category that will be utilized on the project is accounted for and listed. The Department at any time before or after award may require the production of a copy of each applicable Certificate of Registration issued by the United States Department of Labor evidencing such participation by the contractor and any or all of its subcontractors. In order to fulfill the participation requirement, it shall not be necessary that any applicable program sponsor be currently taking or that it will take applications for apprenticeship, training or employment during the performance of the work of this contract or deliver and install proposal.

Bidder: \_\_\_\_\_ By: \_\_\_\_\_ (Signature)  
Address: \_\_\_\_\_ Title: \_\_\_\_\_

NOT FOR

RETURN WITH BID

Affidavit of Illinois Business Office

County DUPAGE  
Local Public Agency VILLAGE OF VILLA PARK  
Section Number N.A.  
Route VARIOUS

State of \_\_\_\_\_ )  
County of \_\_\_\_\_ ) ss.

I, \_\_\_\_\_ of \_\_\_\_\_, \_\_\_\_\_,  
(Name of Affiant) (City of Affiant) (State of Affiant)

being first duly sworn upon oath, states as follows:

1. That I am the \_\_\_\_\_ of \_\_\_\_\_ bidder.  
officer or position
2. That I have personal knowledge of the facts herein stated.
3. That, if selected under this proposal, \_\_\_\_\_, will maintain a  
(bidder)  
business office in the State of Illinois which will be located in \_\_\_\_\_ County, Illinois.
4. That this business office will serve as the primary place of employment for any persons employed in the construction contemplated by this proposal.
5. That this Affidavit is given as a requirement of state law as provided in Section 30-22(8) of the Illinois Procurement Code.

\_\_\_\_\_  
(Signature)  
\_\_\_\_\_  
(Print Name of Affiant)

This instrument was acknowledged before me on \_\_\_\_\_ day of \_\_\_\_\_, \_\_\_\_\_.

(SEAL)

\_\_\_\_\_  
(Signature of Notary Public)

## Affidavit of Availability For the Letting of 05/09/2017

**Instructions:** Complete this form by either typing or using black ink. "Authorization to Bid" will not be issued unless both sides of this form are completed in detail. Use additional forms as needed to list all work.

### Part I. Work Under Contract

List below all work you have under contract as either a prime contractor or a subcontractor. It is required to include all pending low bids not yet awarded or rejected. In a joint venture, list only that portion of the work which is the responsibility of your company. The uncompleted dollar value is to be based upon the most recent engineer's or owners estimate, and must include work subcontracted to others. If no work is contracted, show **NONE**.

	1	2	3	4	Awards Pending	
Contract Number						
Contract With						
Estimated Completion Date						
Total Contract Price						Accumulated Totals
Uncompleted Dollar Value if Firm is the Prime Contractor						
Uncompleted Dollar Value if Firm is the Subcontractor						
<b>Total Value of All Work</b>						

### Part II. Awards Pending and Uncompleted Work to be done with your own forces.

List below the uncompleted dollar value of work for each contract and awards pending to be completed with your own forces. All work subcontracted to others will be listed on the reverse of this form. In a joint venture, list only that portion of the work to be done by your company. If no work is contracted, show **NONE**.

						Accumulated Totals
Earthwork						
Portland Cement Concrete Paving						
HMA Plant Mix						
HMA Paving						
Clean & Seal Cracks/Joints						
Aggregate Bases & Surfaces						
Highway, R.R. and Waterway Structures						
Drainage						
Electrical						
Cover and Seal Coats						
Concrete Construction						
Landscaping						
Fencing						
Guardrail						
Painting						
Signing						
Cold Milling, Planning & Rotomilling						
Demolition						
Pavement Markings (Paint)						
Other Construction (List)						
						\$ 0.00
<b>Totals</b>						

Disclosure of this information is **REQUIRED** to accomplish the statutory purpose as outlined in the "Illinois Procurement Code." Failure to comply will result in non-issuance of an "Authorization To Bid." This form has been approved by the State Forms Management Center.

**Part III. Work Subcontracted to Others.**

For each contract described in Part I, list all the work you have subcontracted to others.

	1	2	3	4	Awards Pending
Subcontractor					
Type of Work					
Subcontract Price					
Amount Uncompleted					
Subcontractor					
Type of Work					
Subcontract Price					
Amount Uncompleted					
Subcontractor					
Type of Work					
Subcontract Price					
Amount Uncompleted					
Subcontractor					
Type of Work					
Subcontract Price					
Amount Uncompleted					
Subcontractor					
Type of Work					
Subcontract Price					
Amount Uncompleted					
Subcontractor					
Type of Work					
Subcontract Price					
Amount Uncompleted					
Total Uncompleted					

I, being duly sworn, do hereby declare that this affidavit is a true and correct statement relating to ALL uncompleted contracts of the undersigned for Federal, State, County, City and private work, including ALL subcontract work, ALL pending low bids not yet awarded or rejected and ALL estimated completion dates.

Subscribed and sworn to before me  
 this \_\_\_\_\_ day of \_\_\_\_\_, \_\_\_\_\_ Type or Print Name \_\_\_\_\_  
 Officer or Director Title

Signed \_\_\_\_\_

Notary Public

My commission expires \_\_\_\_\_

(Notary Seal)

Company \_\_\_\_\_

Address \_\_\_\_\_

**Local Public Agency  
Formal Contract**

PROPOSAL SUBMITTED BY		
Contractor's Name		
Street	P.O. Box	
City	State	Zip Code

STATE OF ILLINOIS

COUNTY DUPAGE  
VILLAGE OF VILLA PARK  
(Name of City, Village, Town or Road District)

FOR THE IMPROVEMENT OF  
PROJECT NAME 2017 STREET IMPROVEMENTS  
SECTION NO. N.A.  
TYPES OF FUNDS LOCAL FUNDING

- SPECIFICATIONS (required)       PLANS (required)       CONTRACT BOND (when required)

**NOT FOR BID**

County DUPAGE  
Local Public Agency VILLAGE OF VILLA PARK  
Section Number N.A.  
Route VARIOUS

1. THIS AGREEMENT, made and concluded the \_\_\_\_\_ day of \_\_\_\_\_, \_\_\_\_\_  
Month and Year  
between the \_\_\_\_\_ Village of Villa Park  
acting by and through its Board of Trustees known as the party of the first part, and  
\_\_\_\_\_ his/their executors, administrators, successors or assigns,  
known as the party of the second part.

2. Witnesseth: That for and in consideration of the payments and agreements mentioned in the Proposal hereto attached, to be made and performed by the party of the first part, and according to the terms expressed in the Bond referring to these presents, the party of the second part agrees with said party of the first part at his/their own proper cost and expense to do all the work, furnish all materials and all labor necessary to complete the work in accordance with the plans and specifications hereinafter described, and in full compliance with all of the terms of this agreement and the requirements of the Engineer under it.

3. And it is also understood and agreed that the LPA Formal Contract Proposal, Special Provisions, Affidavit of Illinois Business Office, Apprenticeship or Training Program Certification, and Contract Bond hereto attached, and the Plans for Route: VARIOUS, in the Village of Villa Park, approved by the Village of Villa Park on April 21, 2017, are essential documents of this  
Date  
contract and are a part hereof.

4. IN WITNESS WHEREOF, The said parties have executed these presents on the date above mentioned.

Attest: \_\_\_\_\_ The Village of Villa Park  
\_\_\_\_\_  
Village Clerk By \_\_\_\_\_  
Party of the First Part

(Seal) \_\_\_\_\_  
*(If a Corporation)*  
Corporate Name \_\_\_\_\_

By \_\_\_\_\_  
President Party of the Second Part  
*(If a Co-Partnership)*

Attest: \_\_\_\_\_  
\_\_\_\_\_  
Secretary

Partners doing Business under the firm name of

\_\_\_\_\_  
Party of the Second Part

*(If an individual)*

\_\_\_\_\_  
Party of the Second Part



Route VARIOUS  
 County DUPAGE  
 Local Agency VILLAGE OF VILLA PARK  
 Section N.A.

We , \_\_\_\_\_

a/an)  Individual  Co-partnership  Corporation organized under the laws of the State of \_\_\_\_\_ ,  
as PRINCIPAL, and \_\_\_\_\_

\_\_\_\_\_ as SURETY,

are held and firmly bound unto the above Local Agency (hereafter referred to as "LA") in the penal sum of \_\_\_\_\_

\_\_\_\_\_ Dollars ( \_\_\_\_\_ ), lawful money of the United States, well and truly to be paid unto said LA, for the payment of which we bind ourselves, our heirs, executors, administrators, successors, jointly to pay to the LA this sum under the conditions of this instrument.

WHEREAS THE CONDITION OF THE FOREGOING OBLIGATION IS SUCH that, the said Principal has entered into a written contract with the LA acting through its awarding authority for the construction of work on the above section, which contract is hereby referred to and made a part hereof, as if written herein at length, and whereby the said Principal has promised and agreed to perform said work in accordance with the terms of said contract, and has promised to pay all sums of money due for any labor, materials, apparatus, fixtures or machinery furnished to such Principal for the purpose of performing such work and has further agreed to pay all direct and indirect damages to any person, firm, company or corporation suffered or sustained on account of the performance of such work during the time thereof and until such work is completed and accepted; and has further agreed that this bond shall inure to the benefit of any person, firm, company or corporation to whom any money may be due from the Principal, subcontractor or otherwise for any such labor, materials, apparatus, fixtures or machinery so furnished and that suit may be maintained on such bond by any such person, firm, company or corporation for the recovery of any such money.

NOW THEREFORE, if the said Principal shall well and truly perform said work in accordance with the terms of said contract, and shall pay all sums of money due or to become due for any labor, materials, apparatus, fixtures or machinery furnished to him for the purpose of constructing such work, and shall commence and complete the work within the time prescribed in said contract, and shall pay and discharge all damages, direct and indirect, that may be suffered or sustained on account of such work during the time of the performance thereof and until the said work shall have been accepted, and shall hold the LA and its awarding authority harmless on account of any such damages and shall in all respects fully and faithfully comply with all the provisions, conditions and requirements of said contract, then this obligation to be void; otherwise to remain in full force and effect.

IN TESTIMONY WHEREOF, the said PRINCIPAL and the said SURETY have caused this instrument to be signed by their respective officers this \_\_\_\_\_ day of \_\_\_\_\_ A.D. \_\_\_\_\_

**PRINCIPAL**

\_\_\_\_\_  
(Company Name)

\_\_\_\_\_  
(Company Name)

By: \_\_\_\_\_  
(Signature & Title)

By: \_\_\_\_\_  
(Signature & Title)

Attest: \_\_\_\_\_  
(Signature & Title)

Attest: \_\_\_\_\_  
(Signature & Title)

(If PRINCIPAL is a joint venture of two or more contractors, the company names and authorized signature of each contractor must be affixed.)

STATE OF ILLINOIS,

COUNTY OF \_\_\_\_\_

I, \_\_\_\_\_, a Notary Public in and for said county, do hereby certify that

\_\_\_\_\_  
(Insert names of individuals signing on behalf of PRINCIPAL)

who are each personally known to me to be the same persons whose names are subscribed to the foregoing instrument on behalf of PRINCIPAL, appeared before me this day in person and acknowledged respectively, that they signed and delivered said instrument as their free and voluntary act for the uses and purposes therein set forth.

Given under my hand and notarial seal this \_\_\_\_\_ day of \_\_\_\_\_ A.D. \_\_\_\_\_

My commission expires \_\_\_\_\_ Notary Public (SEAL)

**SURETY**

\_\_\_\_\_  
(Name of Surety)

By: \_\_\_\_\_  
(Signature of Attorney-in-Fact)

STATE OF ILLINOIS.

COUNTY OF \_\_\_\_\_

I, \_\_\_\_\_, a Notary Public in and for said county, do hereby certify that

\_\_\_\_\_  
(Insert names of individuals signing on behalf of SURETY)

who are each personally known to me to be the same persons whose names are subscribed to the foregoing instrument on behalf of SURETY, appeared before me this day in person and acknowledged respectively, that they signed and delivered said instrument as their free and voluntary act for the uses and purposes therein set forth.

Given under my hand and notarial seal this \_\_\_\_\_ day of \_\_\_\_\_ A.D. \_\_\_\_\_

My commission expires \_\_\_\_\_ Notary Public (SEAL)

Approved this \_\_\_\_\_ day of \_\_\_\_\_, A.D. 2017

Attest: \_\_\_\_\_  
\_\_\_\_\_  
Village Clerk

\_\_\_\_\_  
Village of Villa Park  
(Awarding Authority)  
\_\_\_\_\_  
(Chairman/Mayor/President)



**VILLAGE OF VILLA PARK**

**CONTRACT DOCUMENTS**

**FOR**

**2017 STREET IMPROVEMENTS**

**SPECIAL PROVISIONS**

**NOT FOR BID**

**INDEX OF SPECIAL PROVISIONS**

<b>TITLE</b>	<b>PAGE NO.</b>
DEFINITIONS.....	4
LOCATION OF PROJECT .....	4
DESCRIPTION OF PROJECT .....	5
<b><u>GENERAL SPECIAL PROVISIONS</u></b>	
QUALIFICATIONS OF BIDDERS.....	6
BID PRICE LIMITATIONS.....	8
BID TO REMAIN SUBJECT TO ACCEPTANCE.....	8
SUBCONTRACTORS .....	8
COMPLETION OF PROJECT .....	9
COMPLETION OF PROJECT – INTERIM DEADLINES.....	9
FINAL INSPECTION .....	10
WORKING HOURS.....	10
HOLIDAYS .....	10
PUBLIC CONVENIENCE AND SAFETY (D-1).....	11
INSURANCE .....	11
MAINTENANCE WARRANTY.....	11
MOBILIZATION .....	12
CONSTRUCTION SAFETY AND HEALTH STANDARDS.....	12
PORTABLE TOILET.....	12
MAINTENANCE OF ROADWAYS .....	13
KEEPING ROADS OPEN TO TRAFFIC .....	13
RESPONSIBILITY FOR VANDALISM.....	13
CONCRETE WASHOUT FACILITY .....	13
USE OF FIRE HYDRANTS .....	14
OPERATION OF WATER DISTRIBUTION FACILITIES.....	15
PROTECTION OF EXISTING DRAINAGE FACILITIES DURING CONSTRUCTION .....	15
DRAINAGE AND INLET PROTECTION UNDER TRAFFIC (D-1) .....	16
BRACING AND SHEETING .....	17
EARTHWORK.....	17
FRICTION AGGREGATE (D-1).....	18
HMA MIXTURE DESIGN REQUIREMENTS (D-1).....	21
RECLAIMED ASPHALT PAVEMENT AND RECLAIMED ASPHALT SHINGLES (D-1) .....	27

**2017 STREET IMPROVEMENTS  
VILLAGE OF VILLA PARK**

GROUND TIRE RUBBER (GTR) MODIFIED ASPHALT BINDER (D-1).....	36
FRAMES, GRATES, AND LIDS .....	38
ADJUSTING RINGS.....	38
SALVAGE AND DISPOSAL OF EXISTING MATERIALS .....	39
DATE OF MANUFACTURE .....	39
TRAFFIC CONTROL PLAN .....	39

**PAY ITEM SPECIAL PROVISIONS**

PAY ITEM #2 – TREE ROOT PRUNING .....	40
PAY ITEMS #10 & #11 – AGGREGATE SUBGRADE IMPROVEMENT (D-1) .....	40
PAY ITEM #17 – BITUMINOUS MATERIALS (TACK COAT).....	42
PAY ITEM #19 – HOT-MIX ASPHALT SURFACE REMOVAL – BUTT JOINT .....	43
PAY ITEM #20 – PORTLAND CEMENT CONCRETE SURFACE REMOVAL – BUTT JOINT .....	43
PAY ITEMS #29 & #30 – CLASS C & D PATCHES.....	44
PAY ITEMS #32 & #33 – STORM SEWERS, CLASS A .....	44
PAY ITEMS #35 & #36 – STORM SEWERS, CLASS B .....	44
PAY ITEM #37 – FIRE HYDRANTS TO BE MOVED (SPECIAL) .....	45
PAY ITEM #38 – FIRE HYDRANTS WITH AUXILIARY VALVE AND VALVE BOX.....	46
PAY ITEM #46 – VALVE VAULTS, TYPE A .....	48
PAY ITEMS #57 & #58 – HOT-MIX ASPHALT DRIVEWAY PAVEMENT.....	49
PAY ITEM #60 – DRAINAGE AND UTILITY STRUCTURES TO BE ADJUSTED.....	49
PAY ITEM #61 – DRAINAGE AND UTILITY STRUCTURES TO BE RECONSTRUCTED .....	50
PAY ITEMS #62 & #63 – STORM SEWER (WATER MAIN REQUIREMENTS).....	50
PAY ITEM #64 – SAWING P.C. CONCRETE PAVEMENT (FULL DEPTH).....	51
PAY ITEM #65 – TOPSOIL FURNISH AND PLACE, 4” (SPECIAL).....	51
PAY ITEM #66 – EXPLORATION TRENCH, SPECIAL .....	51
PAY ITEM #67 – SODDING, SPECIAL.....	52
PAY ITEM #68 –TEMPORARY ACCESS (DRIVEWAY ENTRANCE).....	52
PAY ITEM #69 –TEMPORARY ACCESS (ROAD) .....	53
PAY ITEMS #70 & #71 – PORTLAND CEMENT CONCRETE DRIVEWAY PAVEMENT .....	54
PAY ITEMS #72 & #73 – PORTLAND CEMENT CONCRETE SIDEWALK.....	55
PAY ITEM #74 – PORTLAND CEMENT CONCRETE SURFACE REMOVAL (VARIABLE DEPTH) .....	55
PAY ITEM #75 – HOT-MIX ASPHALT SURFACE REMOVAL, VARIABLE DEPTH.....	56
PAY ITEM #76 – PAVEMENT REMOVAL (SPECIAL).....	57
PAY ITEM #77 – VALVE BOXES TO BE ADJUSTED (SPECIAL) .....	57
PAY ITEM #78 – CONCRETE CURB (SPECIAL).....	58

PAY ITEM #79 – COMBINATION CONCRETE CURB AND GUTTER, TYPE B-6.12 (SPECIAL) ..	58
PAY ITEM #80 – TRAFFIC CONTROL AND PROTECTION, (SPECIAL) .....	60
PAY ITEM #81 – CONNECTION TO EXISTING WATER MAIN (NON PRESSURE).....	62
PAY ITEM #82 – PRECONSTRUCTION VIDEO TAPING.....	63
PAY ITEM #83 – SANITARY SEWER CLEAN OUT .....	65
PAY ITEMS #84 & #85 – SANITARY SEWER REPAIR, REMOVE AND REPLACE.....	65
PAY ITEM #86 – SANITARY MANHOLES.....	67
PAY ITEM #87 – GEOGRID.....	67
PAY ITEM #88 – REMOVE DECORATIVE STONE .....	69
PAY ITEM #89 – WATER USAGE DEDUCTION.....	69
PAY ITEM #90 – WATER USAGE CREDIT .....	70
PAY ITEM #91 – CONTINGENCY ALLOWANCE.....	70

**APPENDIX 1:**

- INDEX FOR SUPPLEMENTAL SPECIFICATIONS AND RECURRING SPECIAL PROVISIONS
- CHECK SHEET FOR RECURRING SPECIAL PROVISIONS
- BDE SPECIAL PROVISIONS
- LOCAL ROADS SPECIAL PROVISIONS
- DUPAGE COUNTY PREVAILING WAGES

**APPENDIX 2:**

- IDOT STANDARD DRAWINGS

**APPENDIX 3:**

- AMENDING THE REQUIREMENTS OF BIDDERS FOR CONSTRUCTION PROJECTS
- IRMA CONTRACTUAL INSURANCE GUIDELINES

**APPENDIX 4:**

- SWPPP & IEPA FORMS

**APPENDIX 5:**

- PAVEMENT CORES AND SOIL BORINGS
- LPC 663 CCDD CERTIFICATION

**PROJECT SPECIAL PROVISIONS  
FOR  
2017 STREET IMPROVEMENTS**

The following Special Provisions supplement the “Standard Specifications for Road and Bridge Construction”, adopted April 1, 2016 (referred to hereinafter as the Standard Specifications); the “Supplemental Specifications and Recurring Special Provisions”, adopted January 1, 2017; the latest edition of the “Illinois Manual on Uniform Traffic Control Devices For Streets and Highways” (IMUTCD); and the “Standard Specifications for Water and Sewer Construction in Illinois”, 7<sup>th</sup> Edition, 2014 (hereinafter referred to as the Water and Sewer Specifications). In case of conflict with any part, or parts, of said Specifications, the said Special Provisions shall take precedence and shall govern. Where no conflict exists, the said Specifications shall apply to this Contract as if repeated in their entirety herein.

**DEFINITIONS**

**Contractor.** The individual, firm, partnership, joint venture, or corporation contracting with the Village of Villa Park for performance of prescribed work.

**Department, Owner or Village.** The Village of Villa Park, DuPage County, Illinois.

**Engineer.** The Resident Engineer who is the authorized representative of the Village of Villa Park in immediate charge of the engineering details of a construction project.

**Notice to Proceed.** Notice to proceed is defined as one of the following events, whichever occurs first:

- a.) 10 calendar days after the Contract has been signed by both parties;
- b.) The day a written Notice to Proceed is issued by the Village; or
- c.) The day that construction materials or equipment are delivered to the job site.

**LOCATION OF PROJECT**

The proposed work is officially known as the “2017 Street Improvements”. The project involves various improvements in multiple locations throughout the Village of Villa Park, County of DuPage, State of Illinois:

<b>Street Improvement</b>	<b>Starting Limit</b>		<b>Ending Limit</b>		<b>Notes</b>
ADAMS	FROM	ADDISON	TO	ARDMORE	GAP MICHIGAN
GRANT	FROM	TERRY	TO	MONROE	-
CROSS	FROM	TERRY	TO	JULIA	-
RIDGE	FROM	ADDISON	TO	HARVARD	MULTIPLE GAPS
SUNSET	FROM	ADDISON	TO	YALE	MULTIPLE GAPS
HARVARD	FROM	IL ROUTE 64	TO	DEAD-END	-

HARVARD	FROM	1025 N. HARVARD	TO	BELDEN	ALTERNATE
BELDEN	FROM	HARVARD	TO	DEAD-END	ALTERNATE
WASHINGTON	FROM	IL ROUTE 83	TO	DEAD-END	-
SITE PLAN	FIRE STATION PAVEMENT				-
SITE PLAN	GOLF COURSE PARKING LOT				-

**DESCRIPTION OF PROJECT**

The scope of work includes a variety of roadway improvement methods ranging from pavement resurfacing to pavement reconstruction. The majority of the roadways are being reconstructed with new HMA pavement and curb and gutter. The remainder of the roadways are being resurfaced with varying levels of pavement patching and curb and gutter replacement based on field conditions. There are 2 proposed site plan improvements included in this contract. Also, this contract includes an alternate bid for the construction and connection of Belden Avenue with Harvard Avenue.

In general, the work required for the various types of improvements described above are as follows:

- **Pavement Resurfacing** – The existing HMA or PCC surface will be removed and a new HMA surface with leveling binder will be installed. The existing pavement base and curb and gutter will be inspected for any necessary pavement patching and spot repairs of the curb and gutter. Partial reconstruction of HMA & PCC driveway aprons may be required if curb and gutter is replaced in front of them.
- **Partial Pavement Reconstruction** – The existing HMA pavement will be removed and a new HMA surface and binder course will be installed. To meet the existing surface profile with the new HMA pavement, removal of some existing aggregate base course material may be needed. Before the exiting aggregate base is prepared for HMA pavement construction, aggregate base spot repairs may be needed as determined by the Engineer in the field. This work will also include the replacement of combination concrete curb and gutter along with partial reconstruction of HMA & PCC driveway aprons.
- **Pavement Reconstruction** – The existing pavement and curb and gutter will be removed. HMA & PCC driveway aprons will be partially reconstructed. The reconstruction section will be composed of a new combination concrete curb and gutter, Type B-6.12 or Type B-4.12 with 4” of aggregate base course supported on top of geotechnical fabric or geogrid. The proposed pavement will have 2” of HMA surface course, 4” of HMA binder course, and 6” of aggregate base course supported on top of geotechnical fabric or geogrid. Washington Street will be the only reconstructed roadway which will consist of a thicker pavement structure composed of 2” HMA surface course, 6” HMA binder course, and 8” aggregate base course supported on geotechnical fabric.

Certain streets will need some sanitary and drainage improvements. Grant Avenue and Cross Street will require the replacement of an existing 36” corrugated metal pipe sewer system which goes through private property and Terry Lane. Sidewalks at intersections will need to be replaced and re-graded to meet the Public Right-of-Way Accessibility Guidelines (PROWAG) which includes detectable warnings at curb ramps. Further work will include the installation of erosion control measures, landscaping, pavement markings, sign panel relocation, and all other collateral work performed as shown in the plans and described herein.

## GENERAL SPECIAL PROVISIONS

### QUALIFICATIONS OF BIDDERS

Bidders will comply with all applicable Federal, State and local laws and requirements, and will further meet the qualifications prescribed in this and other applicable portions of these provisions.

Bidder, in submitting a Bid, certifies that Bidder is in compliance with all applicable Federal, State and local laws and requirements, and that Bidder further meets the qualifications prescribed in this and other applicable portions of these provisions. Engineer's determination as to the compliance and qualifications of the Bidder will be final, and Bidder, in submitting a Bid, agrees to be bound by that determination.

Bidder, in submitting a Bid, certifies that Bidder is in compliance with the following requirements and qualifications. Bidder further certifies that Bidder is able to provide written evidence of Bidder's compliance with the following requirements and qualifications. Bidder shall, upon request by Engineer, submit such written evidence within five (5) calendar days of the Engineer's request, as well as any other written evidence which Engineer may deem necessary for the purpose of evaluating Bidder's qualifications.

- (a) Bidder shall be qualified to do business in the State of Illinois.
- (b) Bidder shall possess either a valid Federal Employer Tax Identification Number (FEIN) or a valid Social Security Number (SSN).
- (c) Bidder shall be able to provide a street address and description of the Bidder's place of business, and the mailing address of the business, if different from the street address.
- (d) Bidder shall be able to provide the number of years Bidder has been engaged in the contracting business under the present firm name, and the name of the state where incorporated.
- (e) Bidder shall be able to provide a list of the property and equipment available to the Bidder.
- (f) Bidder shall be able to provide a financial statement demonstrating that the Bidder has the financial resources to meet all obligations related to the Work.
- (g) Bidder shall maintain insurance policies with the coverages required by the Contract, and with the minimum limits of coverage required by the Contract. Bidder shall be able to provide current certificate(s) of insurance for the insurance policies held by Bidder, demonstrating that Bidder holds insurance policies with the coverages required by the contract, and with the minimum limits of coverage required by the Contract.
- (h) Bidder shall have constructed a minimum of three (3) projects of a similar nature in the immediate past five (5) years. Bidder shall be able to provide a list of all projects of a similar nature constructed by Bidder in the immediate past five (5) years, which list shall contain the minimum of three (3) such projects, which list shall provide a description and the location(s) of all such projects, and shall contain the Bidder's performance record and references, as well as the names and current contact information, including addresses and telephone numbers, of

**2017 STREET IMPROVEMENTS  
VILLAGE OF VILLA PARK**

persons who acted as owners' representatives for those projects and who have knowledge of those projects, and whom Bidder agrees the Village may contact for the purpose of verifying Bidder's performance and references.

- (i) Bidder shall be able to provide a list of three (3) references (name, address and telephone number) with knowledge of the integrity and business practices of the bidder. Such references may not be persons who have been employed by Bidder as employees.
- (j) Bidder shall be able to provide a list of projects presently under Contract, the awarded Contract amount of each, the approximate adjusted Contract amount of each (if applicable), and the dollar amount or percent of completion of each.
- (k) Bidder shall be able to provide a list of Contracts which have resulted in lawsuits, whether against Bidder as a prime contractor, against Bidder as a subcontractor, or against Bidder as a party in any other capacity; or against subcontractors or suppliers performing work for Bidder or under Contract held by Bidder.
- (l) Bidder shall be able to provide a list of Contracts defaulted.
- (m) Bidder shall be able to provide a statement indicating whether or not Bidder has ever filed bankruptcy.
- (n) Bidder shall be able to provide a list of all officers of the firm, which list shall also indicate those officers who, while in the employ of the firm or in the employ of previous firms, were associated with Contracts which resulted in lawsuits, Contracts defaulted, or firms which filed for bankruptcy.
- (o) Bidder shall maintain personnel guaranteed to be employed in the responsible charge of the Work, which personnel possess sufficient technical experience to ensure the satisfactory completion of the Work. Bidder shall be able to provide the names and technical experience of such personnel, as well as statements as to whether the personnel have or have not performed satisfactorily on other contracts of like nature and magnitude or comparable difficulty at similar rate of progress.
- (p) Bidder shall be able to provide a list of subcontractors and suppliers anticipated to be employed by Bidder for the purpose of completing the Work, including the firm name, street address and description of place of business; mailing address of business (if different); phone, fax and e-mail contact information of business; name of primary contact; and a list of any projects or contracts for which Bidder currently owes monies to said firm, which list shall include a description of the project or contract, the amount currently due to said firm, the period of time for which those monies have been owed, and the expected date of payment of those monies.
- (q) Bidder shall participate in active apprenticeship and training programs approved by and registered with the United States Department of Labor Bureau of Apprenticeship and Training for each of the trades of work contemplated under the Contract. Bidder shall be able to provide evidence of Bidder's participation in such apprenticeship and training programs.
- (r) Bidder shall only employ subcontractors who meet the requirements prescribed in this section and other sections of these specifications.

- (s) Bidder shall be able to provide such other information as may assist the Village in determining whether the Bidder is adequately prepared to fulfill the Contract.

These requirements and qualifications are not intended to discourage bidding, to make it difficult for qualified Bidders to submit Bids, or to discourage beginning contractors. The purpose of these requirements and qualifications is to allow the Village to obtain sufficient information about Bidder's financial state, available equipment, personnel, and previous work experience so that the Village may mitigate the hazards involved in awarding contracts to parties who may not be qualified to perform the Work as specified.

A copy of Village of Villa Park Ordinance No. 3733, amending the requirements of bidders for construction projects, is provided in Appendix 3.

### **BID PRICE LIMITATIONS**

The bid price for TRAFFIC CONTROL AND PROTECTION shall not exceed 5 percent of the total bid price. If the bid price for TRAFFIC CONTROL AND PROTECTION exceeds 5 percent of the total bid price, the Village may reject the Bid.

The bid price for CONSTRUCTION LAYOUT shall not exceed 2 percent of the total bid price. If the bid price for CONSTRUCTION LAYOUT exceeds 2 percent of the total bid price, the Village may reject the Bid.

The bid price for PRECONSTRUCTION VIDEO TAPING shall not exceed 1 percent of the total bid price. If the bid price for PRECONSTRUCTION VIDEO TAPING exceeds 1 percent of the total bid price, the Village may reject the Bid.

Bidder, in submitting a Bid, certifies that the Bid is in compliance with these requirements. The Village's determination as to whether or not to reject a Bid that does not comply with these requirements will be final, and Bidder, in submitting a Bid, agrees to be bound by that determination.

### **BID TO REMAIN SUBJECT TO ACCEPTANCE**

All bids shall remain subject to acceptance by the Village for a period of 60 calendar days from the date of the bid opening. The Village may extend the acceptance period by up to an additional 60 calendar days upon written notice to all bidders by the Village. The Village may, in its sole discretion, release any bid and return the bid bond prior to the end of the acceptance period.

### **SUBCONTRACTORS**

Add the following paragraph to the end of Article 108.01 of the Standard Specifications:

"The apparent low Bidder shall submit to the Village within 7 calendar days after the receipt of bids, a list of the names of Bidder's proposed subcontractors and material suppliers along with a description of the work to be performed or the materials to be supplied by each."

## COMPLETION OF PROJECT

All work shall be substantially completed and the roadways fully open to traffic as specified with these contract documents, less punch list items, within **108 calendar days** of Notice to Proceed.

Punch list items, including Final Inspection per Article 105.13 of the Standard Specifications, are to be completed within 14 calendar days of substantial completion. In the event the Contractor does not complete the work within the specified calendar days allotted by the contract, then Article 108.09 of the Standard Specifications shall apply except that “working days” will be replaced with “calendar days” in the specified article. Liquidated damages will accrue at a per calendar day rate defined by the table in Article 108.09 of the Standard Specifications.

## COMPLETION OF PROJECT – INTERIM DEADLINES

In order to minimize the duration a roadway is left unpaved, the Contractor will construct the roadway in a timely manner as defined in this special provision for the various types of improvements:

For roadways to be reconstructed, the Contractor shall install the proposed curb and gutter, aggregate base course, and HMA binder course within the following calendar days:

- Adams Street – 28 calendar days
- Cross Street – 21 calendar days
- Grant Avenue – 21 calendar days
- Sunset Drive (in front of school) – 21 calendar days
- Harvard Avenue (dead end) – 21 calendar days
- Washington Street – 21 calendar days

For roadways to be resurfaced, the Contractor shall perform pavement patching, repair curb and gutter, and install HMA leveling binder within the following calendar days:

- Sunset Drive – 21 calendar days
- Ridge Road – 21 calendar days
- Harvard Avenue – 21 calendar days

The countdown of calendar days for a specific roadway will begin when removal operations begin for that specific roadway. Removal operations for reconstruction areas shall be defined as the removal of pavement and curb and gutter. Removal operations for resurfacing areas shall be defined as the removal of existing pavement surface. The duration of calendar days are specific to each roadway and cannot be combined cumulatively. If the Contractor chooses to begin work on multiple roadways at the same time, then the countdown of calendar days will be initiated for multiple roadways at the same time.

Sunset Drive between Harvard Avenue and Yale Avenue is located in front of a school. Construction operations for this area will not begin until school is out of session for summer break and must be completed before school resumes operation. Construction operations shall only be performed in this area between June 1, 2017 and August 11, 2017.

Failure to complete this work within the calendar day durations and timeframes specified above will result in liquidated damages which will accrue at a per calendar day rate as defined by the Special

Provision "Completion of Project" described herein.

## FINAL INSPECTION

Final inspection shall be in accordance with Article 105.13 of the Standard Specifications, except as modified herein.

Revise the second paragraph of Article 105.13 to read:

"If the inspection discloses any work, in whole or in part, as being unsatisfactory, the Engineer will give the Contractor the necessary instructions for correction of same, and the Contractor shall comply with such instructions within 14 calendar days of receipt of such instructions. The Contractor shall give the Engineer not less than 48 hours notice, in writing, prior to beginning any such corrective work. Upon completion of all corrective work, the Contractor shall give the Engineer notice in writing. Upon receipt of such notice, the Engineer will make another inspection which shall constitute the final inspection provided the work has been satisfactorily completed. In such event, the Engineer will notify the Contractor in writing of the date of final inspection."

## WORKING HOURS

Working hours will be between 7:00 A.M. and 5:00 P.M., Monday through Friday, excluding legal holidays as designated by the Contract.

Contractor will not permit the performance of work outside these working hours without Owner's written consent, which may be given after prior written request to Engineer, except as otherwise required for the safety of persons or the work or property at the site or adjacent thereto, and except as otherwise stated in the contract documents.

If Contractor permits the performance of work outside these working hours, Contractor will compensate Owner for the costs of inspection and other services provided by Engineer. Owner will determine the rates at which such inspection and other services are to be compensated. Owner will determine the interval or intervals at which billing will take place, and may, at Owner's discretion, submit invoices for payment to Contractor, or deduct the costs from any monies due or to become due to the Contractor from Owner.

## HOLIDAYS

Revise the list of legal holidays in Article 107.09 of the Standard Specifications to read:

New Year's Day  
Easter  
Memorial Day  
Independence Day  
Labor Day

Thanksgiving Day  
Thanksgiving Friday  
Christmas Eve  
Christmas Day  
New Year's Eve

**PUBLIC CONVENIENCE AND SAFETY (D-1)**

Effective: May 1, 2012

Revised: July 15, 2012

Add the following to the end of the fourth paragraph of Article 107.09:

“If the holiday is on a Saturday or Sunday, and is legally observed on a Friday or Monday, the length of Holiday Period for Monday or Friday shall apply.”

Add the following sentence after the Holiday Period table in the fourth paragraph of Article 107.09:

“The Length of Holiday Period for Thanksgiving shall be from 5:00 AM the Wednesday prior to 11:59 PM the Sunday After”

Delete the fifth paragraph of Article 107.09 of the Standard Specifications:

“On weekends, excluding holidays, roadways with Average Daily Traffic of 25,000 or greater, all lanes shall be open to traffic from 3:00 P.M. Friday to midnight Sunday except where structure construction or major rehabilitation makes it impractical.”

**INSURANCE**

Insurance and indemnification shall be according to applicable sections of the Standard Specifications, and shall also be according to the “IRMA Contractual Insurance Guidelines”, incorporated herein as Appendix 3. If a conflict is determined to exist between the requirements prescribed in the Standard Specifications and the requirements prescribed in the IRMA Contractual Insurance Guidelines, such conflict will be resolved as follows:

- a. If a particular type of insurance coverage is required by one standard but not by both, that type of insurance coverage will be required.
- b. If the minimum limits of insurance coverage required by one standard differ from those required by the other standard, the higher minimum limits of insurance coverage will prevail.
- c. If any other conflicts are determined to exist between the requirements prescribed in the two standards, the stricter of the two requirements will prevail. Owner will make the final determination as to what constitutes a stricter requirement.

**MAINTENANCE WARRANTY**

The Contractor shall execute and deliver to the Village, before final payment will be issued, a written warranty, in a form satisfactory to the Village, which guarantees that all work is in accordance with the contract and will not be defective. This warranty shall guarantee all work for a period of 1 year from the date of final inspection.

The Contractor shall furnish a warranty bond in an amount equal to 10 percent of the final contract amount, or \$200,000, whichever is greater, by a surety satisfactory to the Village to guarantee Contractor’s warranty to repair defective work.

If, within the warranty period, the Village determines any work to be defective, a written notice of such deficiency will be sent to the Contractor by certified mail.

The Contractor shall, within 14 calendar days of receipt of the notice of deficiency, and without cost to the Village, correct or repair such defective work, or remove and replace the defective work in accordance with the contract requirements for the item or items in question.

If Contractor desires an extension of time to complete the corrective work, Contractor shall make such request in writing within 10 calendar days of receipt of the notice of deficiency. After the Contractor has filed a request for an extension of time, the Village will notify the Contractor, in writing, whether or not such extension will be approved.

Should the Contractor fail to complete the corrective work within the 14 calendar days or within such extended time as may have been allowed, the Contractor shall be liable and shall pay to the Village the amount shown in the Schedule of Deductions for Each Day of Overrun in Contract Time, not as a penalty but as liquidated damages, for each day of overrun beyond the 14 calendar days or such extended time as may have been allowed

## **MOBILIZATION**

**Description.** Mobilization shall be performed in accordance with Section 671 of the Standard Specifications, with the following modifications:

**Basis of Payment.** Mobilization will not be paid for separately but shall be considered as included in the unit bid prices of the contract, and additional compensation will not be allowed.

## **CONSTRUCTION SAFETY AND HEALTH STANDARDS**

It is a condition of this contract and shall be made a condition of each subcontract entered into pursuant to this contract that the Contractor and any Subcontractor shall not require any laborer or mechanic employed in performance of the contract to work in surroundings or under working conditions which are unsanitary, hazardous or dangerous to their health or safety, as determined under Federal Construction Safety and Health Standards.

## **PORTABLE TOILET**

**Description.** Contractor shall furnish a portable toilet meeting Federal, State and local health department requirements stocked with lavatory and sanitary supplies at all times. The portable toilet shall be provided at a location approved by the Engineer. The portable toilet shall be maintained in a clean and sanitary condition and shall be emptied as needed.

**Basis of Payment.** This work will not be paid for separately but shall be considered as included in the unit bid prices of the contract, and additional compensation will not be allowed.

## MAINTENANCE OF ROADWAYS

Effective: September 30, 1985

Revised: November 1, 1996

Beginning on the date that work begins on this project, the Contractor shall assume responsibility for normal maintenance of all existing roadways within the limits of the improvement. This normal maintenance shall include all repair work deemed necessary by the Engineer, but shall not include snow removal operations. Traffic control and protection for maintenance of roadways will be provided by the Contractor as required by the Engineer.

If items of work have not been provided in the contract, or otherwise specified for payment, such items, including the accompanying traffic control and protection required by the Engineer, will be paid for in accordance with Article 109.04 of the "Standard Specifications".

## KEEPING ROADS OPEN TO TRAFFIC

All roads shall remain open to traffic unless otherwise shown on the contract plans. When necessary to close one lane because of construction, the Contractor shall maintain one-way traffic during construction hours with the use of signs and flaggers as shown on the Traffic Control Standards. Two lanes of traffic will be maintained during nights and weekends when no construction activities are being carried on.

## RESPONSIBILITY FOR VANDALISM

The Contractor shall be responsible for the protection of all equipment and materials. Any equipment or materials which are stolen, missing, damaged or vandalized shall be the Contractor's responsibility to repair or replace as needed at no additional cost to the contract.

The Contractor shall be responsible for the defacement of any concrete pours before they have set up. Concrete pavement, sidewalk, driveway, or curbing that has been defaced, in the opinion of the Engineer, shall be removed and replaced by the Contractor at Contractor's own expense.

## CONCRETE WASHOUT FACILITY

**Description.** The Contractor shall take sufficient precautions to prevent pollution of streams, lakes, reservoirs, and wetlands with fuels, oils, bitumens, calcium chloride, or other harmful materials according to Article 107.23 of the Standard Specifications.

**General.** To prevent pollution by residual concrete and/or the by-product of washing out the concrete trucks, concrete washout facilities shall be constructed and maintained on any project which includes cast-in-place concrete items. The concrete washout shall be constructed, maintained, and removed according to this special provision.

The concrete washout facility shall be constructed on the job site in accordance with Illinois Urban Manual practice standard for Temporary Concrete Washout Facility (Code 954). The Contractor may elect to use a pre-fabricated portable concrete washout structure. The Contractor shall submit a plan for the concrete washout facility, to the Engineer for approval, a minimum of 10 calendar days before the first concrete pour. The working concrete washout facility shall be in place before any delivery of

concrete to the site. The Contractor shall ensure that all concrete washout activities are limited to the designated area.

The concrete washout facility shall be located no closer than 50 feet from any environmentally sensitive areas, such as water bodies, wetlands, and/or other areas indicated on the Plans. Adequate signage shall be placed at the washout facility and elsewhere as necessary to clearly indicate the location of the concrete washout facility to the operators of concrete trucks.

The concrete washout facility shall be adequately sized to fully contain the concrete washout needs of the project. The contents of the concrete washout facility shall not exceed 75% of the facility capacity. Once the 75% capacity is reached, concrete placement shall be discontinued until the facility is cleaned out. Hardened concrete shall be removed and properly disposed of outside the right-of-way. Slurry shall be allowed to evaporate, or shall be removed and properly disposed of outside the right-of-way. The Contractor shall immediately replace damaged basin liners or other washout facility components to prevent leakage of concrete waste from the washout facility. Concrete washout facilities shall be inspected by the Contractor after each use. Any and all spills shall be reported to the Engineer and cleaned up immediately. The Contractor shall remove the concrete washout facility when it is no longer needed.

**Basis of Payment.** This work will not be paid for separately but shall be considered as included in the unit bid prices of the contract, and additional compensation will not be allowed.

#### USE OF FIRE HYDRANTS

Revise Article 107.18 of the Standard Specifications to read:

**“107.18 Use of Fire Hydrants.** If Contractor requires water for the completion of construction operations, and desires to obtain water from the Village, the Contractor shall make written application to the Village. If such application is approved by the Village, the Contractor shall obtain water from the fire hydrant located at 100 West Home Avenue, adjacent to the Village of Villa Park Fleet Maintenance Garage. Contractor’s use of said hydrant and methods of obtaining water shall be in compliance with all applicable ordinances, rules, and regulations concerning such use. Contractor shall furnish all labor and equipment necessary to make a connection to said hydrant, and to obtain and transport water.

Prior to obtaining water, Contractor shall make written application to the Village for temporary use of a hydrant meter. If the application for temporary use of a hydrant meter is approved, the Contractor shall provide a deposit of three-thousand dollars (\$3,000.00) to the Village for the temporary use of said hydrant meter, which deposit will be held by the Village until such time that the meter is returned to the Village by the Contractor in satisfactory condition. Contractor shall use said hydrant meter when obtaining water, and shall comply with all conditions for the use of said meter. Contractor shall return the hydrant meter to the Village within 24 hours of project completion and within 24 hours of any request by the Village that the hydrant meter be returned.

If Contractor makes application for temporary use of a hydrant meter and the application is not approved, Contractor shall make record of the quantity of water obtained, along with the date and time obtained, and shall report such information after each use to the Village of Villa Park Public Works Department, 11 West Home Avenue. If such use takes place outside of the normal working hours of the Public Works Department, Contractor shall report such information immediately upon the commencement of normal working hours.

Contractor shall not use, operate or obtain water from any hydrants other than the hydrant prescribed. Contractor shall not obtain water from the Village for construction operations or activities not under contract with the Village.

If a water main break occurs and the Village determines that the water main break is a result of Contractor's use of a hydrant, the Village may require the Contractor to repair the water main break in accordance with all applicable construction standards and requirements and at no cost to the contract, or may repair the water main break by other means and invoice the Contractor for reimbursement of the Village's costs.

Water usage will be measured according to the Special Provisions WATER USAGE DEDUCTION and WATER USAGE CREDIT."

### **OPERATION OF WATER DISTRIBUTION FACILITIES**

Contractor shall not operate any water distribution facilities, including, but not limited to, valves or hydrants. If Contractor requires the operation of such facilities, Contractor shall provide a minimum of 48 hours notice to the Village and the Village will operate such facilities.

### **PROTECTION OF EXISTING DRAINAGE FACILITIES DURING CONSTRUCTION**

Unless otherwise noted in the contract plans, the existing drainage facilities shall remain in use during the period of construction.

Locations of existing drainage structures and sewers as shown on the contract plans are approximate. Prior to commencement of work, the Contractor, at his own expense, shall determine the exact location of existing structures which are within the proposed construction site.

All drainage structures are to be kept free from any debris resulting from construction operations. All work and materials necessary to prevent accumulation of debris in the drainage structure resulting from construction operations shall be removed at the Contractor's own expense, and no extra compensation will be allowed.

Unless reconstruction or adjustment of an existing manhole, catch basin, or inlet is called for in the contract plans or ordered by the Engineer, the proposed work shall meet the existing elevations of these structures. Should reconstruction or adjustment of a drainage structure be required by the Engineer in the field, the necessary work and payment shall be done in accordance with Section 602 and Article 104.02 respectively, of the Standard Specifications.

Existing frames and grates are to remain unless otherwise noted in the contract plans or as directed by the Engineer. Frames and grates that are missing or damaged prior to construction shall be replaced. The type of replacements frame or grate shall be determined by the Engineer, and replacement and payment for same shall be in accordance with Section 604 and Article 104.02 respectively, of the Standard Specifications unless otherwise noted in the plans or special provisions.

**DRAINAGE AND INLET PROTECTION UNDER TRAFFIC (D-1)**

Effective: April 1, 2011

Revised: April 2, 2011

Add the following to Article 603.02 of the Standard Specifications:

- “(i) Temporary Hot-Mix Asphalt (HMA) Ramp (Note 1) ..... 1030
- “(j) Temporary Rubber Ramps (Note 2)

Note 1. The HMA shall have maximum aggregate size of 3/8 in. (95 mm).

Note 2. The rubber material shall be according to the following.

Property	Test Method	Requirement
Durometer Hardness, Shore A	ASTM D 2240	75 ±15
Tensile Strength, psi (kPa)	ASTM D 412	300 (2000) min
Elongation, percent	ASTM D 412	90 min
Specific Gravity	ASTM D 792	1.0 - 1.3
Brittleness, °F (°C)	ASTM D 746	-40 (-40)”

Revise Article 603.07 of the Standard Specifications to read:

**603.07 Protection Under Traffic.** After the casting has been adjusted and the Class PP concrete has been placed, the work shall be protected by a barricade and two lights according to Article 701.17(e)(3)b.

When castings are under traffic before the final surfacing operation has been started, properly sized temporary ramps shall be placed around the drainage and/or utility castings according to the following methods.

- (a) Temporary Asphalt Ramps. Temporary hot-mix asphalt ramps shall be placed around the casting, flush with its surface and decreasing to a featheredge in a distance of 2 ft. (600 mm) around the entire surface of the casting.
- (b) Temporary Rubber Ramps. Temporary rubber ramps shall only be used on roadways with permanent posted speeds of 40 mph or less and when the height of the casting to be protected meets the proper sizing requirements for the rubber ramps as shown below.

Dimension	Requirement
Inside Opening	Outside dimensions of casting + 1 in. (25 mm)
Thickness at inside edge	Height of casting ± 1/4 in. (6 mm)
Thickness at outside edge	1/4 in. (6 mm) max.
Width, measured from inside opening to outside edge	8 1/2 in. (215 mm) min

Placement shall be according to the manufacturer's specifications.

Temporary ramps for castings shall remain in place until surfacing operations are undertaken within the immediate area of the structure. Prior to placing the surface course, the temporary ramp shall be removed. Excess material shall be disposed of according to Article 202.03."

## BRACING AND SHEETING

**Description.** The Contractor, if necessary, shall furnish, place and maintain all bracing and sheeting to safeguard adjacent utilities, as well as the work done under this contract.

**Construction Methods.** If at any time the method being used by the Contractor for supporting any material, highway or utility structure adjacent to any excavation is not reasonably safe, in the opinion of the Engineer, the Engineer may require and the Contractor shall provide additional bracing and support necessary to furnish the added degree of safety required by the Engineer. The Contractor shall provide such additional bracing and support by any method approved by the Engineer, as he may elect to use, but the taking of such added precautions shall in no way relieve the Contractor of his sole and final responsibility for the safety of lives, work and structures.

**Basis of Payment.** The cost of such required bracing and sheeting will not be paid for separately but shall be considered as included in the unit bid prices of the contract, and additional compensation will not be allowed.

## EARTHWORK

**Description.** The Village did a detailed soil investigation and analysis during the design phase of this project to determine the presence of any non-special waste material. The LPC 662 & 663 forms along with pertinent exhibits showing the extent of non-special waste material have been included in Appendix 5. This work shall be performed in accordance with Sections 202 and 669 of the Standard Specifications, with the following modifications:

The Contractor is expected to coordinate with the soil disposal site the soil results found in Appendix 5 prior to any excavation operations. The Contractor is also expected to keep the clean construction demolition debris (CCDD) material separate from the non-special waste material indicated by their locations shown in the soil exhibits found in Appendix 5. The Contractor is not allowed to claim the entire project site as non-special waste disposal just because one sample location was tested and displayed non-special waste material.

The Village will not be responsible for any additional soil disposal costs if the soil disposal site chosen by the Contractor rejects loads due to photoionization readings. Photoionization detector (PID) readings are not acceptable results for determining classification of the excavated material. Should a licensed landfill reject any load, analytical chemical testing shall be performed on the excavated material by an IEPA National Environmental Laboratory Accreditation Program (NELAP) approved laboratory on representative samples obtained in accordance with standard IEPA protocol and frequencies. The analytical chemical testing shall be completed by a qualified, independent testing agency hired and paid for by the Contractor. SW-846 Analytical Laboratory Procedures (USEPA) methods will be used for analysis. If the test results are inconclusive, or when the test results indicate levels that do not exceed the Residential Tier 1 Soil and/or Class One Groundwater Remediation

Objectives (SRO & GRO) presented in 35 Illinois Administrative Code 742 (IAC) the removal and disposal of the excavated material shall be classified as EARTH EXCAVATION or REMOVAL AND DISPOSAL OF UNSUITABLE MATERIAL as defined in Section 202 of the Standard Specifications and further defined below. The Contractor shall be responsible for transporting this material to a site that will accept the material. No additional compensation will be allowed for this testing, transportation or disposal.

When test results indicate that the materials exceed said SROs and GROs objectives, the material shall be classified as Non-Special Waste. All costs for excavation, testing, transportation and disposal of Non-Special Waste shall be included in the contract unit price for NON-SPECIAL WASTE DISPOSAL.

Disposal operations shall only proceed with the authorization of the Engineer. The Village has the right to require that **all** sampling be performed in the presence of the Engineer or the Village's authorized representative.

**Method of Measurement.** No adjustment to the awarded contract unit prices for EARTH EXCAVATION, REMOVAL AND DISPOSAL OF UNSUITABLE MATERIAL and NON-SPECIAL WASTE DISPOSAL pay items will be allowed because of changes to quantities based on actual field conditions. At locations where existing pavement removal and excavation is indicated in the plans, or as otherwise directed by the Engineer, it may be necessary to remove underlying unsuitable soils. It is understood and agreed that the actual need for removal of unsuitable material will be determined in the field at the time of construction by the Engineer.

**Basis of Payment.** Earth excavation will be paid for at the contract unit price per cubic yard for EARTH EXCAVATION. Removal and disposal of unsuitable and/or unstable material will be paid for at the contract unit price per cubic yard for REMOVAL AND DISPOSAL OF UNSUITABLE MATERIAL. The excavation, testing, transportation, and disposal of soil and other materials from an excavation determined to be contaminated as described above and indicated in Appendix 5 will be paid for at the contract unit price per cubic yard for NON-SPECIAL WASTE DISPOSAL. All prices shall include other items of work included under the general heading of Earthwork for which no payment item is included in the contract.

**FRICITION AGGREGATE (D-1)**

Effective: January 1, 2011

Revised: April 29, 2016

Revise Article 1004.03(a) of the Standard Specification to read:

**1004.03 Coarse Aggregate for Hot-Mix Asphalt (HMA).** The aggregate shall be according to Article 1004.01 and the following.

(a) **Description.** The coarse aggregate for HMA shall be according to the following table.

Use	Mixture	Aggregates Allowed
-----	---------	--------------------

**2017 STREET IMPROVEMENTS  
VILLAGE OF VILLA PARK**

Use	Mixture	Aggregates Allowed
Class A	Seal or Cover	<u>Allowed Alone or in Combination</u> <sup>5/</sup> : Gravel Crushed Gravel Carbonate Crushed Stone Crystalline Crushed Stone Crushed Sandstone Crushed Slag (ACBF) Crushed Steel Slag Crushed Concrete
HMA Low ESAL	Stabilized Subbase or Shoulders	<u>Allowed Alone or in Combination</u> <sup>5/</sup> : Gravel Crushed Gravel Carbonate Crushed Stone Crystalline Crushed Stone Crushed Sandstone Crushed Slag (ACBF) Crushed Steel Slag <sup>1/</sup> Crushed Concrete
HMA High ESAL Low ESAL	Binder IL-19.0 or IL-19.0L  SMA Binder	<u>Allowed Alone or in Combination</u> <sup>5/ 6/</sup> : Crushed Gravel Carbonate Crushed Stone <sup>2/</sup> Crystalline Crushed Stone Crushed Sandstone Crushed Slag (ACBF) Crushed Concrete <sup>3/</sup>
HMA High ESAL Low ESAL	C Surface and Leveling Binder IL-9.5 or IL-9.5L  SMA Ndesign 50 Surface	<u>Allowed Alone or in Combination</u> <sup>5/</sup> : Crushed Gravel Carbonate Crushed Stone <sup>2/</sup> Crystalline Crushed Stone Crushed Sandstone Crushed Slag (ACBF) Crushed Steel Slag <sup>4/</sup> Crushed Concrete <sup>3/</sup>
HMA High ESAL	D Surface and Leveling Binder IL-9.5  SMA Ndesign 50 Surface	<u>Allowed Alone or in Combination</u> <sup>5/</sup> : Crushed Gravel Carbonate Crushed Stone (other than Limestone) <sup>2/</sup> Crystalline Crushed Stone Crushed Sandstone Crushed Slag (ACBF) Crushed Steel Slag <sup>4/</sup> Crushed Concrete <sup>3/</sup>
		<u>Other Combinations Allowed:</u>

**2017 STREET IMPROVEMENTS  
VILLAGE OF VILLA PARK**

Use	Mixture	Aggregates Allowed	
		<i>Up to...</i>	<i>With...</i>
		25% Limestone	Dolomite
		50% Limestone	Any Mixture D aggregate other than Dolomite
		75% Limestone	Crushed Slag (ACBF) or Crushed Sandstone
HMA High ESAL	E Surface IL-9.5  SMA Ndesign 80 Surface	<u>Allowed Alone or in Combination</u> <sup>5/ 6/</sup> :	
		Crystalline Crushed Stone Crushed Sandstone Crushed Slag (ACBF) Crushed Steel Slag  No Limestone.	
		<u>Other Combinations Allowed:</u>	
		<i>Up to...</i>	<i>With...</i>
		50% Dolomite <sup>2/</sup>	Any Mixture E aggregate
75% Dolomite <sup>2/</sup>	Crushed Sandstone, Crushed Slag (ACBF), Crushed Steel Slag, or Crystalline Crushed Stone		
75% Crushed Gravel <sup>2/</sup> or Crushed Concrete <sup>3/</sup>	Crushed Sandstone, Crystalline Crushed Stone, Crushed Slag (ACBF), or Crushed Steel Slag		
HMA High ESAL	F Surface IL-9.5  SMA Ndesign 80 Surface	<u>Allowed Alone or in Combination</u> <sup>5/ 6/</sup> :	
		Crystalline Crushed Stone Crushed Sandstone Crushed Slag (ACBF) Crushed Steel Slag No Limestone.	
		<u>Other Combinations Allowed:</u>	
<i>Up to...</i>	<i>With...</i>		

Use	Mixture	Aggregates Allowed	
		50% Crushed Gravel <sup>2/</sup> , Crushed Concrete <sup>3/</sup> , or Dolomite <sup>2/</sup>	Crushed Sandstone, Crushed Slag (ACBF), Crushed Steel Slag, or Crystalline Crushed Stone

- 1/ Crushed steel slag allowed in shoulder surface only.
- 2/ Carbonate crushed stone (limestone) and/or crushed gravel shall not be used in SMA Ndesign 80. In SMA Ndesign 50, carbonate crushed stone shall not be blended with any of the other aggregates allowed alone in Ndesign 50 SMA binder or Ndesign 50 SMA surface.
- 3/ Crushed concrete will not be permitted in SMA mixes.
- 4/ Crushed steel slag shall not be used as leveling binder.
- 5/ When combinations of aggregates are used, the blend percent measurements shall be by volume.”
- 6/ Combining different types of aggregate will not be permitted in SMA Ndesign 80.”

**HMA MIXTURE DESIGN REQUIREMENTS (D-1)**

Effective: January 1, 2013

Revised: April 1, 2016

**1) Design Composition and Volumetric Requirements**

Revise the table in Article 406.06(d) of the Standard Specifications to read:

"MINIMUM COMPACTED LIFT THICKNESS	
Mixture Composition	Thickness, in. (mm)
IL-4.75	3/4 (19)
SMA-9.5, IL-9.5, IL-9.5L	1 1/2 (38)
SMA-12.5	2 (50)
IL-19.0, IL-19.0L	2 1/4 (57)"

Revise the table in Article 1004.03(c) of the Standard Specifications to read:

“Use	Size/Application	Gradation No.
Class A-1, 2, & 3	3/8 in. (10 mm) Seal	CA 16
Class A-1	1/2 in. (13 mm) Seal	CA 15
Class A-2 & 3	Cover	CA 14
HMA High ESAL	IL-19.0 IL-9.5	CA 11 <sup>1/</sup> CA 16, CA 13 <sup>3/</sup>
HMA Low ESAL	IL-19.0L IL-9.5L Stabilized Subbase or Shoulders	CA 11 <sup>1/</sup> CA 16
SMA <sup>2/</sup>	1/2 in. (12.5mm) Binder & Surface IL 9.5 Surface	CA13 <sup>3/</sup> , CA14 or CA16  CA16, CA 13 <sup>3/</sup>

1/ CA 16 or CA 13 may be blended with the gradations listed.

2/ The coarse aggregates used shall be capable of being combined with stone sand, slag sand, or steel slag sand meeting the FA/FM 20 gradation and mineral filler to meet the approved mix design and the mix requirements noted herein.

3/ CA 13 shall be 100 percent passing the 1/2 in. (12.5mm) sieve.

Revise Article 1004.03(e) of the Supplemental Specifications to read:

“(e) Absorption. For SMA the coarse aggregate shall also have water absorption ≤ 2.0 percent.”

Revise the last paragraph of Article 1102.01 (a) (5) of the Standard Specifications to read:

“IL-4.75 and Stone Matrix Asphalt (SMA) mixtures which contain aggregate having absorptions greater than or equal to 2.0 percent, or which contain steel slag sand, shall have minimum surge bin storage plus haul time of 1.5 hours.”

Revise the nomenclature table in Article 1030.01 of the Standard Specifications to read:

“High ESAL	IL-19.0 binder; IL-9.5 surface; IL-4.75; SMA-12.5, SMA-9.5
Low ESAL	IL-19.0L binder; IL-9.5L surface; Stabilized Subbase (HMA) <sup>1/</sup> ; HMA Shoulders <sup>2/</sup>

1/ Uses 19.0L binder mix.

2/ Uses 19.0L for lower lifts and 9.5L for surface lift.”

Revise Article 1030.02 of the Standard Specifications and Supplemental Specifications to read:

“1030.02 **Materials.** Materials shall be according to the following.

Item .....	Article/Section
(a) Coarse Aggregate .....	1004.03
(b) Fine Aggregate .....	1003.03
(c) RAP Material .....	1031
(d) Mineral Filler .....	1011
(e) Hydrated Lime .....	1012.01
(f) Slaked Quicklime (Note 1)	
(g) Performance Graded Asphalt Binder (Note 2) .....	1032
(h) Fibers (Note 3)	
(i) Warm Mix Asphalt (WMA) Technologies (Note 4)	

Note 1. Slaked quicklime shall be according to ASTM C 5.

Note 2. The asphalt binder shall be an SBS PG 76-28 when the SMA is used on a full-depth asphalt pavement and SBS PG 76-22 when used as an overlay, except where modified herein. The asphalt binder shall be an Elvaloy or SBS PG 76-22 for IL-4.75, except where modified herein. The elastic recovery shall be a minimum of 80.

Note 3. A stabilizing additive such as cellulose or mineral fiber shall be added to the SMA mixture according to Illinois Modified AASHTO M 325. The stabilizing additive shall meet the Fiber Quality Requirements listed in Illinois Modified AASHTO M 325. Prior to approval and use of fibers, the Contractor shall submit a notarized certification by the producer of these materials stating they meet these requirements. Reclaimed Asphalt Shingles (RAS) may be used in Stone Matrix Asphalt (SMA) mixtures designed with an SBA polymer modifier as a fiber additive if the mix design with RAS included meets AASHTO T305 requirements. The RAS shall be from a certified source that produces either Type I or Type 2. Material shall meet requirements noted herein and the actual dosage rate will be determined by the Engineer.

Note 4. Warm mix additives or foaming processes shall be selected from the current Bureau of Materials and Physical Research Approved List, “Warm Mix Asphalt Technologies”.

Revise Article 1030.04(a)(1) of the Standard Specifications and the Supplemental Specifications to read:

“(1) High ESAL Mixtures. The Job Mix Formula (JMF) shall fall within the following limits.

High ESAL, MIXTURE COMPOSITION (% PASSING) <sup>1/</sup>										
Sieve Size	IL-19.0 mm		SMA <sup>4/</sup> IL-12.5 mm		SMA <sup>4/</sup> IL-9.5 mm		IL-9.5 mm		IL-4.75 mm	
	min	max	min	max	min	max	min	max	min	max
1 1/2 in. (37.5 mm)										
1 in. (25 mm)		100								
3/4 in. (19 mm)	90	100		100						
1/2 in. (12.5 mm)	75	89	80	100		100		100		100
3/8 in. (9.5 mm)				65	90	100	90	100		100
#4 (4.75 mm)	40	60	20	30	36	50	34	69	90	100
#8 (2.36 mm)	20	42	16	24 <sup>5/</sup>	16	32 <sup>5/</sup>	34 <sup>6/</sup>	52 <sup>2/</sup>	70	90
#16 (1.18 mm)	15	30					10	32	50	65
#30 (600 μm)			12	16	12	18				
#50 (300 μm)	6	15					4	15	15	30
#100 (150 μm)	4	9					3	10	10	18
#200 (75 μm)	3	6	7.0	9.0 <sup>3/</sup>	7.5	9.5 <sup>3/</sup>	4	6	7	9 <sup>3/</sup>
Ratio Dust/Asphalt Binder		1.0		1.5		1.5		1.0		1.0

1/ Based on percent of total aggregate weight.

2/ The mixture composition shall not exceed 44 percent passing the #8 (2.36 mm) sieve for surface courses with Ndesign = 90.

3/ Additional minus No. 200 (0.075 mm) material required by the mix design shall be mineral filler, unless otherwise approved by the Engineer.

4/ The maximum percent passing the #635 (20 μm) sieve shall be ≤ 3 percent.

5/ When establishing the Adjusted Job Mix Formula (AJMF) the percent passing the #8 (2.36 mm) sieve shall not be adjusted above the percentage stated on the table.

6/ When establishing the Adjusted Job Mix Formula (AJMF) the percent passing the #8 (2.36 mm) sieve shall not be adjusted below 34 percent.

Revise Article 1030.04(b)(1) of the Standard Specifications to read:

“(1) High ESAL Mixtures. The target value for the air voids of the HMA shall be 4.0 percent and for IL-4.75 it shall be 3.5 percent at the design number of gyrations. The VMA and VFA of the HMA design shall be based on the nominal maximum size of the aggregate in the mix, and shall conform to the following requirements.

VOLUMETRIC REQUIREMENTS High ESAL				
Ndesign	Voids in the Mineral Aggregate (VMA), % minimum			Voids Filled with Asphalt Binder (VFA), %
	IL-19.0	IL-9.5	IL-4.75 <sup>1/</sup>	
50	13.5	15.0	18.5	65 – 78 <sup>2/</sup>
70				65 - 75
90				

1/ Maximum Draindown for IL-4.75 shall be 0.3 percent

2/ VFA for IL-4.75 shall be 72-85 percent”

Replace Article 1030.04(b)(3) of the Standard Specifications with the following:

“(3) SMA Mixtures.

Volumetric Requirements SMA <sup>1/</sup>			
Ndesign	Design Air Voids Target %	Voids in the Mineral Aggregate (VMA), % min.	Voids Filled with Asphalt (VFA), %
80 <sup>4/</sup>	3.5	17.0 <sup>2/</sup>	75 - 83
		16.0 <sup>3/</sup>	

1/ Maximum draindown shall be 0.3 percent. The draindown shall be determined at the JMF asphalt binder content at the mixing temperature plus 30 °F.

2/ Applies when specific gravity of coarse aggregate is  $\geq 2.760$ .

3/ Applies when specific gravity of coarse aggregate is  $< 2.760$ .

4/ Blending of different types of aggregate will not be permitted. For surface course, the coarse aggregate can be crushed steel slag, crystalline crushed stone or crushed sandstone. For binder course, coarse aggregate shall be crushed stone (dolomite), crushed gravel, crystalline crushed stone, or crushed sandstone.

Add to the end of Article 1030.05 (d) (2) a. of the Standard Specifications:

“During production, the Contractor shall test SMA mixtures for draindown according to AASHTO T305 at a frequency of 1 per day of production.”

Delete last sentence of the second paragraph of Article 1102.01(a) (4) b. 2.

Add to the end of Article 1102.01 (a) (4) b. 2.:

“As an option, collected dust (baghouse) may be used in lieu of manufactured mineral filler according to the following:

- (a.) Sufficient collected dust (baghouse) is available for production of the SMA mix for the entire project.
- (b.) A mix design was prepared based on collected dust (baghouse).

## 2) Design Verification and Production

Revise Article 1030.04 (d) of the Standard Specifications to read:

“(d) Verification Testing. High ESAL, IL-4.75, and SMA mix designs submitted for verification will be tested to ensure that the resulting mix designs will pass the required criteria for the Hamburg Wheel Test (IL mod AASHTO T-324) and the Tensile Strength Test (IL mod AASHTO T-283). The Department will perform a verification test on gyratory specimens compacted by the Contractor. If the mix fails the Department’s verification test, the Contractor shall make the necessary changes to the mix and resubmit compacted specimens to the Department for verification. If the mix fails again, the mix design will be rejected.

All new and renewal mix designs will be required to be tested, prior to submittal for Department verification and shall meet the following requirements:

- (1)Hamburg Wheel Test criteria. The maximum allowable rut depth shall be 0.5 in. (12.5 mm). The minimum number of wheel passes at the 0.5 in. (12.5 mm) rut depth criteria shall be based on the high temperature binder grade of the mix as specified in the mix requirements table of the plans.

Illinois Modified AASHTO T 324 Requirements <sup>1/</sup>

Asphalt Binder Grade	# Repetitions	Max Rut Depth (mm)
PG 70 -XX (or higher)	20,000	12.5
PG 64 -XX (or lower)	10,000	12.5

1/ When produced at temperatures of 275 ± 5 °F (135 ± 3 °C) or less, loose Warm Mix Asphalt shall be oven aged at 270 ± 5 °F (132 ± 3 °C) for two hours prior to gyratory compaction of Hamburg Wheel specimens.

Note: For SMA Designs (N-80) the maximum rut depth is 6.0 mm at 20,000 repetitions.  
For IL 4.75mm Designs (N-50) the maximum rut depth is 9.0mm at 15,000 repetitions.

- (2) Tensile Strength Criteria. The minimum allowable conditioned tensile strength shall be 60 psi (415 kPa) for non-polymer modified performance graded (PG) asphalt binder and 80 psi (550 kPa) for polymer modified PG asphalt binder. The maximum allowable unconditioned tensile strength shall be 200 psi (1380 kPa)."

Production Testing. Revise first paragraph of Article 1030.06(a) of the Standard Specifications to read:

- "(a) High ESAL, IL-4.75, WMA, and SMA Mixtures. For each contract, a 300 ton (275 metric tons) test strip, except for SMA mixtures it will be 400 ton (363 metric ton), will be required at the beginning of HMA production for each mixture with a quantity of 3000 tons (2750 metric tons) or more according to the Manual of Test Procedures for Materials "Hot Mix Asphalt Test Strip Procedures".

Add the following after the sixth paragraph in Article 1030.06 (a) of the Standard Specifications:

"The Hamburg Wheel test shall also be conducted on all HMA mixtures from a sample taken within the first 500 tons (450 metric tons) on the first day of production or during start up with a split reserved for the Department. The mix sample shall be tested according to the Illinois Modified AASHTO T 324 and shall meet the requirements specified herein. Mix production shall not exceed 1500 tons (1350 metric tons) or one day's production, whichever comes first, until the testing is completed and the mixture is found to be in conformance. The requirement to cease mix production may be waived if the plant produced mixture demonstrates conformance prior to start of mix production for a contract.

If the mixture fails to meet the Hamburg Wheel criteria, no further mixture will be accepted until the Contractor takes such action as is necessary to furnish a mixture meeting the criteria"

Method of Measurement:

Add the following after the fourth paragraph of Article 406.13 (b):

"The plan quantities of SMA mixtures shall be adjusted using the actual approved binder and surface Mix Design's  $G_{mb}$ ."

Basis of Payment.

Replace the fourth paragraph of Article 406.14 of the Standard Specifications with the following:

"Stone matrix asphalt will be paid for at the contract unit price per ton (metric ton) for POLYMERIZED HOT-MIX ASPHALT SURFACE COURSE, STONE MATRIX ASPHALT, of the mixture composition and Ndesign specified; and POLYMERIZED HOT-MIX ASPHALT BINDER COURSE, STONE MATRIX ASPHALT, of the mixture composition and Ndesign specified."

## **RECLAIMED ASPHALT PAVEMENT AND RECLAIMED ASPHALT SHINGLES (D-1)**

Effective: November 1, 2012

Revise: April 1, 2017

Revise Section 1031 of the Standard Specifications to read:

**“SECTION 1031. RECLAIMED ASPHALT PAVEMENT AND RECLAIMED ASPHALT SHINGLES**

**1031.01 Description.** Reclaimed asphalt pavement and reclaimed asphalt shingles shall be according to the following.

- (a) Reclaimed Asphalt Pavement (RAP). RAP is the material resulting from cold milling or crushing an existing hot-mix asphalt (HMA) pavement. RAP will be considered processed FRAP after completion of both crushing and screening to size. The Contractor shall supply written documentation that the RAP originated from routes or airfields under federal, state, or local agency jurisdiction.
- (b) Reclaimed Asphalt Shingles (RAS). Reclaimed asphalt shingles (RAS). RAS is from the processing and grinding of preconsumer or post-consumer shingles. RAS shall be a clean and uniform material with a maximum of 0.5 percent unacceptable material, as defined in Bureau of Materials and Physical Research Policy Memorandum, “Reclaimed Asphalt Shingle (RAS) Sources”, by weight of RAS. All RAS used shall come from a Bureau of Materials and Physical Research approved processing facility where it shall be ground and processed to 100 percent passing the 3/8 in. (9.5 mm) sieve and 90 percent passing the #4 (4.75 mm) sieve. RAS shall meet the testing requirements specified herein. In addition, RAS shall meet the following Type 1 or Type 2 requirements.
  - (1) Type 1. Type 1 RAS shall be processed, preconsumer asphalt shingles salvaged from the manufacture of residential asphalt roofing shingles.
  - (2) Type 2. Type 2 RAS shall be processed post-consumer shingles only, salvaged from residential, or four unit or less dwellings not subject to the National Emission Standards for Hazardous Air Pollutants (NESHAP).

**1031.02 Stockpiles.** RAP and RAS stockpiles shall be according to the following.

- (a) RAP Stockpiles. The Contractor shall construct individual, sealed RAP stockpiles meeting one of the following definitions. Additional processed RAP (FRAP) shall be stockpiled in a separate working pile, as designated in the QC Plan, and only added to the sealed stockpile when test results for the working pile are complete and are found to meet tolerances specified herein for the original sealed FRAP stockpile. Stockpiles shall be sufficiently separated to prevent intermingling at the base. All stockpiles (including unprocessed RAP and FRAP) shall be identified by signs indicating the type as listed below (i.e. “Non- Quality, FRAP -#4 or Type 2 RAS”, etc...).
- (1) Fractionated RAP (FRAP). FRAP shall consist of RAP from Class I, Superpave HMA (High and Low ESAL) or equivalent mixtures. The coarse aggregate in FRAP shall be crushed aggregate and may represent more than one aggregate type and/or quality, but shall be at least C quality. All FRAP shall be processed prior to testing and sized into fractions with the separation occurring on or between the #4 (4.75 mm) and 1/2 in. (12.5 mm) sieves. Agglomerations shall be minimized such that 100 percent of the RAP in the coarse fraction shall pass the maximum sieve size specified for the mix the FRAP will be used in.

- (2) Restricted FRAP (B quality) stockpiles shall consist of RAP from Class I, Superpave (High ESAL), or HMA (High ESAL). If approved by the Engineer, the aggregate from a maximum 3.0 in. (75 mm) single combined pass of surface/binder milling will be classified as B quality. All millings from this application will be processed into FRAP as described previously.
- (3) Conglomerate. Conglomerate RAP stockpiles shall consist of RAP from Class I, Superpave HMA (High and Low ESAL) or equivalent mixtures. The coarse aggregate in this RAP shall be crushed aggregate and may represent more than one aggregate type and/or quality, but shall be at least C quality. This RAP may have an inconsistent gradation and/or asphalt binder content prior to processing. All conglomerate RAP shall be processed (FRAP) prior to testing. Conglomerate RAP stockpiles shall not contain steel slag or other expansive material as determined by the Department.
- (4) Conglomerate "D" Quality (DQ). Conglomerate DQ RAP stockpiles shall consist of RAP from HMA shoulders, bituminous stabilized subbases or Superpave (Low ESAL)/HMA (Low ESAL) IL-19.0L binder mixture. The coarse aggregate in this RAP may be crushed or round but shall be at least D quality. This RAP may have an inconsistent gradation and/or asphalt binder content. Conglomerate DQ RAP stockpiles shall not contain steel slag or other expansive material as determined by the Department.
- (5) Non-Quality. RAP stockpiles that do not meet the requirements of the stockpile categories listed above shall be classified as "Non-Quality".

RAP or FRAP containing contaminants, such as earth, brick, sand, concrete, sheet asphalt, bituminous surface treatment (i.e. chip seal), pavement fabric, joint sealants, plant cleanout etc., will be unacceptable unless the contaminants are removed to the satisfaction of the Engineer. Sheet asphalt shall be stockpiled separately.

- (b) RAS Stockpiles. Type 1 and Type 2 RAS shall be stockpiled separately and shall be sufficiently separated to prevent intermingling at the base. Each stockpile shall be signed indicating what type of RAS is present.

However, a RAS source may submit a written request to the Department for approval to blend mechanically a specified ratio of Type 1 RAS with Type 2 RAS. The source will not be permitted to change the ratio of the blend without the Department prior written approval. The Engineer's written approval will be required, to mechanically blend RAS with any fine aggregate produced under the AGCS, up to an equal weight of RAS, to improve workability. The fine aggregate shall be "B Quality" or better from an approved Aggregate Gradation Control System source. The fine aggregate shall be one that is approved for use in the HMA mixture and accounted for in the mix design and during HMA production.

Records identifying the shingle processing facility supplying the RAS, RAS type, and lot number shall be maintained by project contract number and kept for a minimum of three years.

**1031.03 Testing.** FRAP and RAS testing shall be according to the following.

- (a) FRAP Testing. When used in HMA, the FRAP shall be sampled and tested either during processing or after stockpiling. It shall also be sampled during HMA production.

- (1) During Stockpiling. For testing during stockpiling, washed extraction samples shall be run at the minimum frequency of one sample per 500 tons (450 metric tons) for the first 2000 tons (1800 metric tons) and one sample per 2000 tons (1800 metric tons) thereafter. A minimum of five tests shall be required for stockpiles less than 4000 tons (3600 metric tons).
- (2) Incoming Material. For testing as incoming material, washed extraction samples shall be run at a minimum frequency of one sample per 2000 tons (1800 metric tons) or once per week, whichever comes first.
- (3) After Stockpiling. For testing after stockpiling, the Contractor shall submit a plan for approval to the District proposing a satisfactory method of sampling and testing the RAP/FRAP pile either in-situ or by restocking. The sampling plan shall meet the minimum frequency required above and detail the procedure used to obtain representative samples throughout the pile for testing.

Before extraction, each field sample of FRAP, shall be split to obtain two samples of test sample size. One of the two test samples from the final split shall be labeled and stored for Department use. The Contractor shall extract the other test sample according to Department procedure. The Engineer reserves the right to test any sample (split or Department-taken) to verify Contractor test results.

- (b) RAS Testing. RAS shall be sampled and tested during stockpiling according to Bureau of Materials and Physical Research Policy Memorandum, "Reclaimed Asphalt Shingle (RAS) Sources". The Contractor shall also sample as incoming material at the HMA plant.

- (1) During Stockpiling. Washed extraction and testing for unacceptable materials shall be run at the minimum frequency of one sample per 200 tons (180 metric tons) for the first 1000 tons (900 metric tons) and one sample per 1000 tons (900 metric tons) thereafter. A minimum of five samples are required for stockpiles less than 1000 tons (900 metric tons). Once a  $\leq 1000$  ton (900 metric ton), five-sample/test stockpile has been established it shall be sealed. Additional incoming RAS shall be in a separate working pile as designated in the Quality Control plan and only added to the sealed stockpile when the test results of the working pile are complete and are found to meet the tolerances specified herein for the original sealed RAS stockpile.
- (2) Incoming Material. For testing as incoming material at the HMA plant, washed extraction shall be run at the minimum frequency of one sample per 250 tons (227 metric tons). A minimum of five samples are required for stockpiles less than 1000 tons (900 metric tons). The incoming material test results shall meet the tolerances specified herein.

The Contractor shall obtain and make available all test results from start of the initial stockpile sampled and tested at the shingle processing facility in accordance with the facility's QC Plan.

Before extraction, each field sample shall be split to obtain two samples of test sample size. One of the two test samples from the final split shall be labeled and stored for Department use. The Contractor shall extract the other test sample according to Department procedures. The Engineer reserves the right to test any sample (split or Department-taken) to verify Contractor test results.

**1031.04 Evaluation of Tests.** Evaluation of test results shall be according to the following.

- (a) Evaluation of FRAP Test Results. All test results shall be compiled to include asphalt binder content, gradation and, when applicable (for slag),  $G_{mm}$ . A five test average of results from the original pile will be used in the mix designs. Individual extraction test results run thereafter, shall be compared to the average used for the mix design, and will be accepted if within the tolerances listed below.

Parameter	FRAP
No. 4 (4.75 mm)	± 6 %
No. 8 (2.36 mm)	± 5 %
No. 30 (600 μm)	± 5 %
No. 200 (75 μm)	± 2.0 %
Asphalt Binder	± 0.3 %
$G_{mm}$	± 0.03 <sup>1/</sup>

- 1/ For stockpile with slag or steel slag present as determined in the current Manual of Test Procedures Appendix B 21, "Determination of Reclaimed Asphalt Pavement Aggregate Bulk Specific Gravity".

If any individual sieve and/or asphalt binder content tests are out of the above tolerances when compared to the average used for the mix design, the FRAP stockpile shall not be used in Hot-Mix Asphalt unless the FRAP representing those tests is removed from the stockpile. All test data and acceptance ranges shall be sent to the District for evaluation.

The Contractor shall maintain a representative moving average of five tests to be used for Hot-Mix Asphalt production.

With the approval of the Engineer, the ignition oven may be substituted for extractions according to the ITP, "Calibration of the Ignition Oven for the Purpose of Characterizing Reclaimed Asphalt Pavement (RAP)" or Illinois Modified AASHTO T-164-11, Test Method A.

- (b) Evaluation of RAS Test Results. All of the test results, with the exception of percent unacceptable materials, shall be compiled and averaged for asphalt binder content and gradation. A five test average of results from the original pile will be used in the mix designs. Individual test results run thereafter, when compared to the average used for the mix design, will be accepted if within the tolerances listed below.

Parameter	RAS
No. 8 (2.36 mm)	± 5 %
No. 16 (1.18 mm)	± 5 %
No. 30 (600 μm)	± 4 %
No. 200 (75 μm)	± 2.5 %
Asphalt Binder Content	± 2.0 %

If any individual sieve and/or asphalt binder content tests are out of the above tolerances when compared to the average used for the mix design, the RAS shall not be used in Hot-Mix Asphalt unless the RAS representing those tests is removed from the stockpile. All test data and acceptance ranges shall be sent to the District for evaluation.

- (c) Quality Assurance by the Engineer. The Engineer may witness the sampling and splitting conduct assurance tests on split samples taken by the Contractor for quality control testing a minimum of once a month.

The overall testing frequency will be performed over the entire range of Contractor samples for asphalt binder content and gradation. The Engineer may select any or all split samples for assurance testing. The test results will be made available to the Contractor as soon as they become available.

The Engineer will notify the Contractor of observed deficiencies.

Differences between the Contractor's and the Engineer's split sample test results will be considered acceptable if within the following limits.

Test Parameter	Acceptable Limits of Precision	
% Passing: <sup>1/</sup>	FRAP	RAS
1/2 in.	5.0%	
No. 4	5.0%	
No. 8	3.0%	4.0%
No. 30	2.0%	4.0%
No. 200	2.2%	4.0%
Asphalt Binder Content	0.3%	3.0%
G <sub>mm</sub>	0.030	

1/ Based on washed extraction.

In the event comparisons are outside the above acceptable limits of precision, the Engineer will immediately investigate.

- (d) Acceptance by the Engineer. Acceptable of the material will be based on the validation of the Contractor's quality control by the assurance process.

**1031.05 Quality Designation of Aggregate in RAP and FRAP.**

- (a) RAP. The aggregate quality of the RAP for homogeneous, conglomerate, and conglomerate "D" quality stockpiles shall be set by the lowest quality of coarse aggregate in the RAP stockpile and are designated as follows.

- (1) RAP from Class I, Superpave/HMA (High ESAL), or (Low ESAL) IL-9.5L surface mixtures are designated as containing Class B quality coarse aggregate.
- (2) RAP from Superpave/HMA (Low ESAL) IL-19.0L binder mixture is designated as Class D quality coarse aggregate.
- (3) RAP from Class I, Superpave/HMA (High ESAL) binder mixtures, bituminous base course mixtures, and bituminous base course widening mixtures are designated as containing Class C quality coarse aggregate.

(4) RAP from bituminous stabilized subbase and BAM shoulders are designated as containing Class D quality coarse aggregate.

(b) FRAP. If the Engineer has documentation of the quality of the FRAP aggregate, the Contractor shall use the assigned quality provided by the Engineer.

If the quality is not known, the quality shall be determined as follows. Fractionated RAP stockpiles containing plus #4 (4.75 mm) sieve coarse aggregate shall have a maximum tonnage of 5,000 tons (4,500 metric tons). The Contractor shall obtain a representative sample witnessed by the Engineer. The sample shall be a minimum of 50 lb (25 kg). The sample shall be extracted according to Illinois Modified AASHTO T 164 by a consultant laboratory prequalified by the Department for the specified testing. The consultant laboratory shall submit the test results along with the recovered aggregate to the District Office. The cost for this testing shall be paid by the Contractor. The District will forward the sample to the Bureau of Materials and Physical Research Aggregate Lab for MicroDeval Testing, according to ITP 327. A maximum loss of 15.0 percent will be applied for all HMA applications. The fine aggregate portion of the fractionated RAP shall not be used in any HMA mixtures that require a minimum of "B" quality aggregate or better, until the coarse aggregate fraction has been determined to be acceptable thru a MicroDeval Testing.

**1031.06 Use of FRAP and/or RAS in HMA.** The use of FRAP and/or RAS shall be the Contractor's option when constructing HMA in all contracts.

(a) FRAP. The use of FRAP in HMA shall be as follows.

(1) Coarse Aggregate Size (after extraction). The coarse aggregate in all FRAP shall be equal to or less than the nominal maximum size requirement for the HMA mixture to be produced.

(2) Steel Slag Stockpiles. FRAP stockpiles containing steel slag or other expansive material, as determined by the Department, shall be homogeneous and will be approved for use in HMA (High ESAL and Low ESAL) mixtures regardless of lift or mix type.

(3) Use in HMA Surface Mixtures (High and Low ESAL). FRAP stockpiles for use in HMA surface mixtures (High and Low ESAL) shall have coarse aggregate that is Class B quality or better. FRAP shall be considered equivalent to limestone for frictional considerations unless produced/screened to minus 3/8 inch.

(4) Use in HMA Binder Mixtures (High and Low ESAL), HMA Base Course, and HMA Base Course Widening. FRAP stockpiles for use in HMA binder mixtures (High and Low ESAL), HMA base course, and HMA base course widening shall be FRAP in which the coarse aggregate is Class C quality or better.

(5) Use in Shoulders and Subbase. FRAP stockpiles for use in HMA shoulders and stabilized subbase (HMA) shall be FRAP, Restricted FRAP, conglomerate, or conglomerate DQ.

(b) RAS. RAS meeting Type 1 or Type 2 requirements will be permitted in all HMA applications as specified herein.

(c) FRAP and/or RAS Usage Limits. Type 1 or Type 2 RAS may be used alone or in conjunction with FRAP in HMA mixtures up to a maximum of 5.0 percent by weight of the total mix.

When FRAP is used alone or FRAP is used in conjunction with RAS, the percent of virgin asphalt binder replacement (ABR) shall not exceed the amounts indicated in the table below for a given N Design.

**Max Asphalt Binder Replacement for FRAP with RAS Combination**

HMA Mixtures <sup>1/ 2/ 4/</sup>	Maximum % ABR		
	Binder/Leveling Binder	Surface	Polymer Modified <sup>3/</sup>
30L	50	40	30
50	40	35	30
70	40	30	30
90	40	30	30
4.75 mm N-50			40
SMA N-80			30

- 1/ For Low ESAL HMA shoulder and stabilized subbase, the percent asphalt binder replacement shall not exceed 50 % of the total asphalt binder in the mixture.
- 2/ When the binder replacement exceeds 15 % for all mixes, except for SMA and IL-4.75, the high and low virgin asphalt binder grades shall each be reduced by one grade (i.e. 25 % binder replacement using a virgin asphalt binder grade of PG64-22 will be reduced to a PG58-28). When constructing full depth HMA and the ABR is less than 15 %, the required virgin asphalt binder grade shall be PG64-28.
- 3/ When the ABR for SMA or IL-4.75 is 15 % or less, the required virgin asphalt binder shall be SBS PG76-22 and the elastic recovery shall be a minimum of 80. When the ABR for SMA or IL-4.75 exceeds 15%, the virgin asphalt binder grade shall be SBS PG70-28 and the elastic recovery shall be a minimum of 80.
- 4/ When FRAP or RAS is used alone, the maximum percent asphalt binder replacement designated on the table shall be reduced by 10 %.

**1031.07 HMA Mix Designs.** At the Contractor's option, HMA mixtures may be constructed utilizing RAP/FRAP and/or RAS material meeting the detailed requirements specified herein.

- (a) FRAP and/or RAS. FRAP and /or RAS mix designs shall be submitted for verification. If additional FRAP or RAS stockpiles are tested and found to be within tolerance, as defined under "Evaluation of Tests" herein, and meet all requirements herein, the additional FRAP or RAS stockpiles may be used in the original design at the percent previously verified.
- (b) RAS. Type 1 and Type 2 RAS are not interchangeable in a mix design. A RAS stone bulk specific gravity (Gsb) of 2.300 shall be used for mix design purposes.

**1031.08 HMA Production.** HMA production utilizing FRAP and/or RAS shall be as follows.

To remove or reduce agglomerated material, a scalping screen, gator, crushing unit, or comparable sizing device approved by the Engineer shall be used in the RAS and FRAP feed system to remove or reduce oversized material. If material passing the sizing device adversely affects the mix production or quality of the mix, the sizing device shall be set at a size specified by the Engineer.

If during mix production, corrective actions fail to maintain FRAP, RAS or QC/QA test results within control tolerances or the requirements listed herein the Contractor shall cease production of the mixture containing FRAP or RAS and conduct an investigation that may require a new mix design.

- (a) RAS. RAS shall be incorporated into the HMA mixture either by a separate weight depletion system or by using the RAP weigh belt. Either feed system shall be interlocked with the aggregate feed or weigh system to maintain correct proportions for all rates of production and batch sizes. The portion of RAS shall be controlled accurately to within  $\pm 0.5$  percent of the amount of RAS utilized. When using the weight depletion system, flow indicators or sensing devices shall be provided and interlocked with the plant controls such that the mixture production is halted when RAS flow is interrupted.
- (b) HMA Plant Requirements. HMA plants utilizing FRAP and/or RAS shall be capable of automatically recording and printing the following information.

(1) Dryer Drum Plants.

- a. Date, month, year, and time to the nearest minute for each print.
- b. HMA mix number assigned by the Department.
- c. Accumulated weight of dry aggregate (combined or individual) in tons (metric tons) to the nearest 0.1 ton (0.1 metric ton).
- d. Accumulated dry weight of RAS and FRAP in tons (metric tons) to the nearest 0.1 ton (0.1 metric ton).
- e. Accumulated mineral filler in revolutions, tons (metric tons), etc. to the nearest 0.1 unit.
- f. Accumulated asphalt binder in gallons (liters), tons (metric tons), etc. to the nearest 0.1 unit.
- g. Residual asphalt binder in the RAS and FRAP material as a percent of the total mix to the nearest 0.1 percent.
- h. Aggregate RAS and FRAP moisture compensators in percent as set on the control panel. (Required when accumulated or individual aggregate and RAS and FRAP are printed in wet condition.)
- i. When producing mixtures with FRAP and/or RAS, a positive dust control system shall be utilized.
- j. Accumulated mixture tonnage.
- k. Dust Removed (accumulated to the nearest 0.1 ton (0.1 metric ton))

- (2) Batch Plants.
- a. Date, month, year, and time to the nearest minute for each print.
  - b. HMA mix number assigned by the Department.
  - c. Individual virgin aggregate hot bin batch weights to the nearest pound (kilogram).
  - d. Mineral filler weight to the nearest pound (kilogram).
  - f. RAS and FRAP weight to the nearest pound (kilogram).
  - g. Virgin asphalt binder weight to the nearest pound (kilogram).
  - h. Residual asphalt binder in the RAS and FRAP material as a percent of the total mix to the nearest 0.1 percent.

The printouts shall be maintained in a file at the plant for a minimum of one year or as directed by the Engineer and shall be made available upon request. The printing system will be inspected by the Engineer prior to production and verified at the beginning of each construction season thereafter.

**1031.09 RAP in Aggregate Surface Course and Aggregate Wedge Shoulders, Type B.** The use of RAP or FRAP in aggregate surface course and aggregate shoulders shall be as follows.

- (a) Stockpiles and Testing. RAP stockpiles may be any of those listed in Article 1031.02, except "Non-Quality" and "FRAP". The testing requirements of Article 1031.03 shall not apply. RAP used shall be according to the current Bureau of Materials and Physical Research Policy Memorandum, "Reclaimed Asphalt Pavement (RAP) for Aggregate Applications".
- (b) Gradation. The RAP material shall meet the gradation requirements for CA 6 according to Article 1004.01(c), except the requirements for the minus No. 200 (75 µm) sieve shall not apply. The sample for the RAP material shall be air dried to constant weight prior to being tested for gradation."

**GROUND TIRE RUBBER (GTR) MODIFIED ASPHALT BINDER (D-1)**

Effective: June 26, 2006

Revised: April 1, 2016

Add the following to the end of article 1032.05 of the Standard Specifications:

"(c) Ground Tire Rubber (GTR) Modified Asphalt Binder. A quantity of 10.0 to 14.0 percent GTR (Note 1) shall be blended by dry unit weight with a PG 64-28 to make a GTR 70-28 or a PG 58-28 to make a GTR 64-28. The base PG 64-28 and PG 58-28 asphalt binders shall meet the requirements of Article 1032.05(a). Compatible polymers may be added during production. The GTR modified asphalt binder shall meet the requirements of the following table.

<b>Test</b>	<b>Asphalt Grade GTR 70-28</b>	<b>Asphalt Grade GTR 64-28</b>
Flash Point (C.O.C.), AASHTO T 48, °F (°C), min.	450 (232)	450 (232)
Rotational Viscosity, AASHTO T 316 @ 275 °F (135 °C), Poises, Pa·s, max.	30 (3)	30 (3)
Softening Point, AASHTO T 53, °F (°C), min.	135 (57)	130 (54)
Elastic Recovery, ASTM D 6084, Procedure A (sieve waived) @ 77 °F, (25 °C), aged, ss, 100 mm elongation, 5 cm/min., cut immediately, %, min.	65	65

Note 1. GTR shall be produced from processing automobile and/or light truck tires by the ambient grinding method. GTR shall not exceed 1/16 in. (2 mm) in any dimension and shall contain no free metal particles or other materials. A mineral powder (such as talc) meeting the requirements of AASHTO M 17 may be added, up to a maximum of four percent by weight of GTR to reduce sticking and caking of the GTR particles. When tested in accordance with Illinois modified AASHTO T 27, a 50 g sample of the GTR shall conform to the following gradation requirements:

<b>Sieve Size</b>	<b>Percent Passing</b>
No. 16 (1.18 mm)	100
No. 30 (600 μm)	95 ± 5
No. 50 (300 μm)	> 20

Add the following to the end of Note 1. of article 1030.03 of the Standard Specifications:

“A dedicated storage tank for the Ground Tire Rubber (GTR) modified asphalt binder shall be provided. This tank must be capable of providing continuous mechanical mixing throughout by continuous agitation and recirculation of the asphalt binder to provide a uniform mixture. The tank shall be heated and capable of maintaining the temperature of the asphalt binder at 300 °F to 350 °F (149 °C to 177 °C). The asphalt binder metering systems of dryer drum plants shall be calibrated with the actual GTR modified asphalt binder material with an accuracy of ± 0.40 percent.”

Revise 1030.02(c) of the Standard Specifications to read:

“(c) RAP Materials (Note 5) .....1031”

Add the following note to 1030.02 of the Standard Specifications:

Note 5. When using reclaimed asphalt pavement and/or reclaimed asphalt shingles, the maximum asphalt binder replacement percentage shall be according to the most recent special provision for recycled materials.

## FRAMES, GRATES, AND LIDS

Frames, grates, lids and all other castings furnished under this contract shall be in accordance with Section 602 and Section 604 of the Standard Specifications, except as modified herein.

Castings shall conform to ASTM A48 Class 30. Castings shall be free of cracks, holes, swells, cold shuts, and patches. Castings shall not be coated or painted.

Frames, grates, lids and other castings shall be furnished in accordance with the following:

Type 1 frames and closed lids shall be Neenah R-1713 self-sealing or approved equal.

Type 1 frames and open lids shall be Neenah R-1713 or approved equal.

Type 11 frames and grates located in barrier curb and gutter shall be Neenah R-3281-A with curb box or approved equal.

Type 11 frames and grates located in depressed curb and gutter shall be Neenah R-3281-A with depressed curb grate or approved equal.

All other castings not specified above shall be as shown on the plans or as directed by the Engineer. If any of the castings specified are not compatible in the field due to frame height or other constraints, the Contractor shall propose an alternate casting to the Engineer for approval and shall furnish the alternate casting if approved.

Frames, grates, lids and other castings located within curb ramps or crosswalks shall be substituted with ADA compliant castings.

All closed lid castings furnished under this contract shall be self-sealing, gasketed, watertight, and shall have machined bearing surfaces and concealed pick holes. The top surface of all closed lids shall be embossed with the words "VILLAGE OF VILLA PARK". The top surface of closed lids shall also be embossed with the word "SANITARY", "STORM", or "WATER" as appropriate.

Enviro-curb logos on curb boxes for Type 11 frames and grates shall have the words "DUMP NO WASTE" and "DRAINS TO RIVER" or "DRAINS TO WATERWAY" cast into the top of all curb boxes.

This work will not be paid for separately but shall be included in the cost of all pay items that include the furnishing of frames, grates, lids, or other castings.

## ADJUSTING RINGS

All drainage and utility structures which are constructed, reconstructed, or adjusted as a part of this contract shall have adjusting rings installed between the topmost section of the structure and the casting.

Each structure shall be fitted with a minimum of one adjusting ring and a maximum of two adjusting rings. The topmost adjusting ring on each structure shall be rubber. The second adjusting ring on each structure, if needed, shall be precast concrete with steel reinforcement. The total height of all adjusting rings on a single structure shall be a minimum of 2 in. and a maximum of 12 in.

The mating faces of adjusting rings shall be smooth, parallel, and free of cracks, chips, spalling, or casting irregularities. Rubber mastic shall be installed between each joint.

Adjusting rings will not be paid for separately but shall be included in the cost of the items to which this work pertains.

### **SALVAGE AND DISPOSAL OF EXISTING MATERIALS**

Existing manufactured materials which are removed and are not to be reused, including, but not limited to, frames, grates, lids, castings, sign posts, sign panels, fire hydrants, valves, stops, and fittings, shall remain the property of the Village unless the Engineer waives this requirement as specified herein.

Existing manufactured materials which are removed and are not to be reused will be inspected by the Engineer. Materials which are determined by the Engineer to be in satisfactory condition shall remain the property of the Village and shall be delivered by the Contractor to the Village of Villa Park Public Works Department yard located at 51 South Ardmore Avenue in Villa Park. Delivery shall be made during the normal working hours of the Village of Villa Park Public Works Department and the Contractor shall coordinate the day, time, and other details of delivery with the Village.

Materials which are determined by the Engineer to be in unsatisfactory condition shall become the property of the Contractor and shall be removed from the site by the end of the workday and properly disposed of by the Contractor.

The delivery or disposal of materials will not be paid for separately but shall be included in the cost of all items that include removal of existing materials.

### **DATE OF MANUFACTURE**

All manufactured materials furnished under this contract, including, but not limited to, frames, grates, lids, castings, fire hydrants, pipe, drainage and utility structures, valves, stops, and fittings, shall have been manufactured no earlier than January 1 of the calendar year in which they are to be installed.

### **TRAFFIC CONTROL PLAN**

Traffic Control shall be according to the applicable sections of the Standard Specifications, the Supplemental Specifications, the "Illinois Manual on Uniform Traffic Control Devices for Streets and Highways", any special details and Highway Standards contained in the plans, and the Special Provisions contained herein.

Special attention is called to Article 107.09 of the Standard Specifications and the following Highway Standards, Details, Quality Standard for Work Zone Traffic Control Devices, Recurring Special Provisions and Special Provisions contained herein, relating to traffic control.

### **STANDARDS:**

- 701011-04 Off-Rd Moving Operations, 2L, 2W, Day Only
- 701301-04 Lane Closure, 2L, 2W, Short Time Operations

701311-03 Lane Closure, 2L, 2W, Moving Operations - Day Only  
701501-06 Urban Lane Closure, 2L, 2W, Undivided  
701801-06 Sidewalk, Corner or Crosswalk Closure  
701901-06 Traffic Control Devices

DETAILS:

Traffic Control and Protection for Side Roads, Intersections, and Driveways (TC-10)  
District One Typical Pavement Markings (TC-13)

SPECIAL PROVISIONS:

LRS 3 – Work Zone Traffic Control Surveillance  
“Public Convenience and Safety”  
“Maintenance of Roadways”  
“Keeping Roads Open to Traffic”

**PAY ITEM SPECIAL PROVISIONS**

**PAY ITEM #2 – TREE ROOT PRUNING**

**Description.** This work shall be performed in accordance with Section 201 of the Standard Specifications, with the following modifications:

Work under this item shall consist of pruning tree root structures using disc blade trenching equipment, trench backfilling and mulching. Pruning will be required where construction activities will encroach upon critical root zone areas as designated by the Engineer.

The trench width for root pruning shall not exceed 6". Root pruning shall be to a depth of not less than 18". All pruning operations shall be completed prior to beginning any work which would disturb the root zone. The trench shall be backfilled and loosely compacted. Immediately following the completion of root pruning activities, Contractor shall erect protective fencing around those trees designated on the plans, so as to enclose the remainder of the critical root zone as shown in the construction details.

**Method of Measurement.** This work shall also include all fertilizer nutrients and supplemental watering as described in Article 201.06. These items will not be measured for payment separately but shall be considered as included in the cost of TREE ROOT PRUNING.

**Basis of Payment.** Work under this item shall be paid for at the contract unit price per each for TREE ROOT PRUNING.

**PAY ITEMS #10 & #11 – AGGREGATE SUBGRADE IMPROVEMENT (D-1)**

Effective: February 22, 2012  
Revised: April 1, 2016

Add the following Section to the Standard Specifications:

**“SECTION 303. AGGREGATE SUBGRADE IMPROVEMENT**

**303.01 Description.** This work shall consist of constructing an aggregate subgrade improvement.

**303.02 Materials.** Materials shall be according to the following.

Item	Article/Section
(a) Coarse Aggregate .....	1004.07
(b) Reclaimed Asphalt Pavement (RAP) (Notes 1, 2 and 3) .....	1031

Note 1. Crushed RAP, from either full depth or single lift removal, may be mechanically blended with aggregate gradation CS 01 but shall not exceed 40 percent by weight of the total product. The top size of the Coarse RAP shall be less than 4 in. (100 mm) and well graded.

Note 2. RAP having 100 percent passing the 1 1/2 in (37.5 mm) sieve and being well graded, may be used as capping aggregate in the top 3 in. (75 mm) when aggregate gradation CS 01 is used in lower lifts. When RAP is blended with any of the coarse aggregates, the blending shall be done with mechanically calibrated feeders. The final product shall not contain more than 40 percent by weight of RAP.

Note 3. The RAP used for aggregate subgrade improvement shall be according to the current Bureau of Materials and Physical Research Policy Memorandum, “Reclaimed Asphalt Pavement (RAP) for Aggregate Applications”.

**303.03 Equipment.** The vibratory machine shall be according to Article 1101.01, or as approved by the Engineer. The calibration for the mechanical feeders shall have an accuracy of ± 2.0 percent of the actual quantity of material delivered.

**303.04 Soil Preparation.** The stability of the soil shall be according to the Department’s Subgrade Stability Manual for the aggregate thickness specified.

**303.05 Placing Aggregate.** The maximum nominal lift thickness of aggregate gradation CS 01 shall be 24 in. (600 mm).

**303.06 Capping Aggregate.** The top surface of the aggregate subgrade shall consist of a 3 in. (75 mm) of aggregate gradations CA 06 or CA 10. When Reclaimed Asphalt Pavement (RAP) is used, it shall be crushed and screened where 100 percent is passing the 1 1/2 in. (37.5 mm) sieve and being well graded. RAP that has been fractionated to size will not be permitted for use in capping. Capping aggregate will not be required when the aggregate subgrade improvement is used as a cubic yard pay item for undercut applications. When RAP is blended with any of the coarse aggregates, the blending shall be done with mechanically calibrated feeders.

**303.07 Compaction.** All aggregate lifts shall be compacted to the satisfaction of the Engineer. If the moisture content of the material is such that compaction cannot be obtained, sufficient water shall be added so that satisfactory compaction can be obtained.

**303.08 Finishing and Maintenance of Aggregate Subgrade Improvement.** The aggregate subgrade improvement shall be finished to the lines, grades, and cross sections shown on the plans, or as directed by the Engineer. The aggregate subgrade improvement shall be maintained in a smooth and compacted condition.

**303.09 Method of Measurement.** This work will be measured for payment according to Article 311.08.

**303.10 Basis of Payment.** This work will be paid for at the contract unit price per cubic yard (cubic meter) for AGGREGATE SUBGRADE IMPROVEMENT or at the contract unit price per square yard (square meter) for AGGREGATE SUBGRADE IMPROVEMENT, of the thickness specified.

Add the following to Section 1004 of the Standard Specifications:

**“1004.07 Coarse Aggregate for Aggregate Subgrade Improvement.** The aggregate shall be according to Article 1004.01 and the following.

- (a) Description. The coarse aggregate shall be crushed gravel, crushed stone, or crushed concrete. The top 12 inches of the aggregate subgrade improvement shall be 3 inches of capping material and 9 inches of crushed gravel, crushed stone or crushed concrete. In applications where greater than 36 inches of subgrade material is required, rounded gravel, meeting the CS01 gradation, may be used beginning at a depth of 12 inches below the bottom of pavement.
- (b) Quality. The coarse aggregate shall consist of sound durable particles reasonably free of deleterious materials. Non-mechanically blended RAP may be allowed up to a maximum of 5.0 percent.
- (c) Gradation.
  - (1) The coarse aggregate gradation for total subgrade thicknesses of 12 in. (300 mm) or greater shall be CS 01.

COARSE AGGREGATE SUBGRADE GRADATIONS					
Grad No.	Sieve Size and Percent Passing				
	8"	6"	4"	2"	#4
CS 01	100	97 ± 3	90 ± 10	45 ± 25	20 ± 20

COARSE AGGREGATE SUBGRADE GRADATIONS (Metric)					
Grad No.	Sieve Size and Percent Passing				
	200 mm	150 mm	100 mm	50 mm	4.75 mm
CS 01	100	97 ± 3	90 ± 10	45 ± 25	20 ± 20

- (2) The 3 in. (75 mm) capping aggregate shall be gradation CA 6 or CA 10.

**PAY ITEM #17 – BITUMINOUS MATERIALS (TACK COAT)**

**Description.** This work shall be performed in accordance with Section 406 of the Standard Specifications, with the following modifications:

Bituminous tack coat shall be placed at least one hour in advance of the placement of HMA, but no more than forty-eight hours in advance of the placement of HMA. If Contractor places tack coat more

than forty-eight hours in advance of the placement of HMA, the tack coat will not be measured for payment, and Contractor will place tack coat again in accordance with this provision. Tack coat will not be placed on weekends or on legal holidays unless permitted by the Engineer. Tack coat will not be placed before weekends or legal holidays when placement of HMA is not expected to take place until after the weekend or legal holiday, unless permitted by the Engineer.

**Basis of Payment.** This work will be paid for at the contract unit price per pound of residual asphalt for BITUMINOUS MATERIALS (TACK COAT).

#### **PAY ITEM #19 – HOT-MIX ASPHALT SURFACE REMOVAL – BUTT JOINT**

**Description.** This work shall consist of constructing a butt joint and a satisfactory transition between pavement being removed and pavement remaining in place, in accordance with Articles 406.08 and 440.04 of the Standard Specifications, with the following modifications:

Contractor shall saw the joint between pavement remaining and pavement being removed, with a concrete sawing machine. Depth shall be as shown in the plans or construction details. This work shall be done in such a manner that a straight joint will be secured, and this work shall be considered as included in the unit bid price of this item.

The removal of existing pavement surface shall be according to Section 440 of the Standard Specifications. Should any pavement be damaged by removal operations beyond the construction limits shown in the plans to a degree sufficient to warrant replacement in Engineer's judgment, Contractor shall replace it in kind for no additional payment.

**Method of Measurement.** Surface removal will be measured in place and the area computed in square yards. The square yards measured will be paid for only once, regardless of the number of passes needed to remove the material.

**Basis of Payment.** This work will be paid for at the contract unit price per square yard for HOT-MIX ASPHALT SURFACE REMOVAL - BUTT JOINT.

#### **PAY ITEM #20 – PORTLAND CEMENT CONCRETE SURFACE REMOVAL – BUTT JOINT**

**Description.** This work shall consist of constructing a butt joint and a satisfactory transition between pavement being removed and pavement remaining in place, in accordance with Articles 406.08 of the Standard Specifications, with the following modifications:

Contractor shall saw the joint between pavement remaining and pavement being removed, with a concrete sawing machine. Depth shall be as shown in the plans or construction details. This work shall be done in such a manner that a straight joint will be secured, and this work shall be considered as included in the unit bid price of this item.

The removal of existing pavement surface shall be according to Section 440 of the Standard Specifications. Should any pavement be damaged by removal operations beyond the construction limits shown in the plans to a degree sufficient to warrant replacement in Engineer's judgment, Contractor shall replace it in kind for no additional payment.

**Method of Measurement.** Surface removal will be measured in place and the area computed in

square yards. The square yards measured will be paid for only once, regardless of the number of passes needed to remove the material.

**Basis of Payment.** This work will be paid for at the contract unit price per square yard for PORTLAND CEMENT CONCRETE SURFACE REMOVAL - BUTT JOINT.

#### **PAY ITEMS #29 & #30 – CLASS C & D PATCHES**

**Description.** This work shall be performed in accordance with Section 442 and Article 701.17(e) of the Standard Specifications, with the following modifications:

Pavement patching shall not exceed half the roadway width at a time. Pavement patching will not be quantified by type or types of patching areas. The class of patch shall only specify a depth.

All patches shall be saw cut full-depth prior to removal of the existing pavement. Saw cuts shall be completed no more than three days prior to removal of the existing pavement. Saw cutting shall be included in all pavement patching regardless of class specified. Jointing shall be included in all PCC pavement patching.

**Basis of Payment.** This work will be paid for at the contract unit price per square yard for CLASS C PATCHES or CLASS D PATCHES, of the thickness specified.

#### **PAY ITEMS #32 & #33 – STORM SEWERS, CLASS A**

**Description.** This work shall consist of installing storm sewers in accordance with Section 550 of the Standard Specifications, with the following modifications:

**Materials.** The kinds of materials permitted for “CLASS A” storm sewers shall only be reinforced concrete sewer pipe. The designation of “type” which refers to the fill height over the top of the pipe will not be classified in the plans. Instead, the Contractor shall use the rims and inverts provided in the plans to determine the appropriate fill height and strength class of reinforced concrete pipe according to ASTM C76 and Article 550.03 of the Standard Specifications. Should a run of pipe encounter multiple fill heights over the pipe, the more conservative strength class shall be used for the entire pipe run.

**Basis of Payment.** When CLASS A storm sewers are specified, this work will be paid for at the contract unit price per foot for STORM SEWERS, CLASS A, of the diameter specified.

#### **PAY ITEMS #35 & #36 – STORM SEWERS, CLASS B**

**Description.** This work shall consist of installing storm sewers in accordance with Section 550 of the Standard Specifications, with the following modifications:

**Materials.** The kinds of materials permitted for “CLASS B” storm sewers shall only be polyvinyl chloride (PVC) pipe. The PVC pipe shall have a Standard Dimension Ratio (SDR) of 26 conforming to ASTM D2241 with gasket joints conforming to ASTM D3212. If PVC pipe material per ASTM D2241 is not available, then an alternate material designation can be requested to the Engineer for approval. All supplied pipes and fittings must be from the same manufacturer. Connections to

existing sewer lines shall be made using non-shear Fernco RC Series or Mission Flex-Seal adjustable repair couplings equipped with stainless steel bands.

**Basis of Payment.** When CLASS B storm sewers are specified, this work will be paid for at the contract unit price per foot for STORM SEWERS, CLASS B, of the diameter specified.

**PAY ITEM #37 – FIRE HYDRANTS TO BE MOVED (SPECIAL)**

**Description.** This work shall consist of moving and adjusting existing fire hydrants with auxiliary valves and valve boxes as shown in the plans or as directed by the Engineer according to Sections 561 and 564 of the Standard Specifications and Sections 41 and 45 of the Water and Sewer Specifications, with the following modifications:

This work shall also include the removal and disposal of the existing 6" lead pipe and the installation of a new 6" ductile iron pipe necessary to make the connection between the existing water main tee and the proposed fire hydrant location.

**Materials.** Fire hydrant barrel extensions, if permitted, shall be AMERICAN Flow Control Waterous Series and shall be a maximum of 18 in.

Ductile iron pipe shall be Class 52 or 54 conforming to the requirements of ANSI/AWWA-C111/A21.11 and ANSI/AWWA-C151/A21.51. The pipe shall be cement mortar lined and tar coated in accordance with AWWA C104. Each length of pipe furnished shall be clearly marked to indicate pipe size, pipe class and material designation. Joints for water main installed in open trench shall be mechanical or push-on.

**Installation.** Fire hydrants shall be installed so that the standpipe is plumb. The center of the lowest nozzle shall be placed at least 18 in. but not more than 24 in. above finished grade. The breakable flanges shall be positioned 2 in. above finished grade. The nearest part of the hydrant shall be at least 3 ft. but not more than 8 ft. behind the back of curb. The nearest part of the hydrant shall be at least 3 ft. from all paved surfaces. Where hydrants are to be installed adjacent to a roadway they shall be placed so that the pumper nozzle faces the roadway and is perpendicular to the direction of travel of the roadway. Where hydrants are not to be installed adjacent to a roadway they shall be placed according to the plans or as directed by the Engineer.

Fire hydrants and auxiliary valves shall be set on a firm foundation of precast concrete blocks and shall be thrust blocked. Additional precast concrete bricks shall be placed under the auxiliary valve as needed. Thrust blocking shall consist of Class SI concrete cast in place against the fittings and the undisturbed earth on any side or sides of the excavation where thrust is expected to occur. A minimum of ¼ cu. yd. of concrete shall be used for the thrust blocking. The dimensions of the thrust blocking shall be determined by the Engineer. Thrust blocking may also consist of the placement of precast concrete blocks at the discretion of the Engineer. Additional precast concrete blocks shall be placed on the bottom, back and sides of the hydrant as directed by the Engineer to hold the hydrant solid and vertical. All blocks, bricks and thrust blocking shall be placed such that the pipe, joints and fittings shall be accessible for future repair and so that the hydrant drain holes are not blocked.

Joint restraints shall be installed on all mechanical fittings. Stainless steel threaded tie rods shall be installed between the fire hydrant barrel and the tee fitting on the water main. Barrel extensions will only be permitted at the discretion of the Engineer.

Hydrants shall be braced during backfilling. The area around the base of the hydrant shall be backfilled with a minimum of 1 cu. yd. of washed stone. The washed stone shall be covered with polyethylene sheeting prior to further backfilling. Backfill material shall be placed in lifts not exceeding 6 in. in thickness, loose measurement, and compacted in a manner approved by the Engineer.

Hydrants not in service shall be covered with plastic bags until the hydrants are in service.

Water main piping installed in open trench shall be placed a minimum of 5.5 feet below finished grade or as directed by the Engineer to achieve the necessary clearance from underground utilities or other obstructions.

Considered included in the cost of this item when constructing water main are the following items:

- Construction of water main in "short" tunnels not exceeding five feet in length, past utilities, tree roots, or other obstructions.
- Construction of all required thrust blocking, and other appurtenant work called for by the contract.
- All testing, gas chlorination, sampling, and other work considered incidental as described in the Water and Sewer Specifications. The opening or closing of existing water system valves by contractor to facilitate filling, flushing, testing, etc. shall be done only with the approval and under the supervision of Engineer or Village representative.
- All fittings necessary to make the connections.

All watermain shall be thoroughly flushed and then subjected to a 2 hour pressure and leakage test at 150 PSI by the Contractor and shall be chlorinated in accordance with Village Standards and the Water and Sewer Specifications. Make-up water shall be supplied from an open drum, and the volume of water used shall not exceed that allowed by the Water and Sewer Specifications.

The watermain shall be installed on course aggregate bedding (CA-11) with a minimum thickness of 6 inches. The bedding material shall be placed and compacted to the spring line of the pipe. Blocking of any kind for grade is not permitted.

**Basis of Payment.** This work will be paid for at the contract unit price per each for FIRE HYDRANTS TO BE MOVED (SPECIAL). Excavation, bedding and backfilling of fire hydrants and ductile iron pipe will not be paid for separately but shall be included in the cost of this work.

#### **PAY ITEM #38 – FIRE HYDRANTS WITH AUXILIARY VALVE AND VALVE BOX**

**Description.** This work shall consist of constructing fire hydrants with auxiliary valves and valve boxes at the locations shown on the plans or as directed by the Engineer. This work shall be performed in accordance with applicable portions of Sections 561 and 564 of the Standard Specifications, the construction details provided in the plans and Sections 41 and 45 of the Water and Sewer Specifications, with the following modifications:

This work shall also include the 6" ductile iron pipe necessary to make the connection between the existing water main and the proposed fire hydrant location.

**Materials.** Fire hydrants shall be AMERICAN Flow Control 5-¼" Waterous Pacer Fire Hydrant Model WB67-250, conforming with ANSI/AWWA C502, 6' - 0" bury depth, with all stainless steel trim, above-ground breakable flanges, and auxiliary resilient wedge gate valve and valve box. Hydrants

shall be fitted with DDP-arrangement nozzle sections with one 4-½ in. pumper nozzle and two 2-½ in. hose nozzles with National Standard threads and a National Standard operating nut.

Fire hydrants shall be factory painted red, prime coated with an epoxy, and finish coated with a two-part polyurethane top coat. Hydrants that are not factory painted red will be considered unacceptable and will be rejected.

Fire hydrants which are to be constructed on existing water mains where a 6' - 0" bury depth is incompatible with the depth of the existing water main may be substituted with a fire hydrant of a different bury depth as approved by the Engineer.

Auxiliary valves shall be AMERICAN Flow Control Series 2500 Resilient Wedge Gate Valves conforming with ANSI/AWWA C515, with flanged and mechanical joint ends, 6 in. diameter. All trim bolts shall be stainless steel.

Valve boxes shall have a cover embossed with the word "WATER". Mechanical joint restraints shall be EBAA Iron, Inc., MEGALUG Mechanical Joint Restraints for Ductile Iron Pipe, or approved equal.

Valve box stabilizer grips shall be by BLR Enterprises, Inc., or approved equal.

All hardware and fasteners to be installed below grade shall be stainless steel. Bolts and threaded rods shall be Type 304 stainless steel and nuts and washers shall be Type 300 stainless steel.

Fire hydrant barrel extensions, if permitted, shall be AMERICAN Flow Control Waterous Series and shall be a maximum of 18 in.

Ductile iron pipe shall be Class 52 or 54 conforming to the requirements of ANSI/AWWA-C111/A21.11 and ANSI/AWWA-C151/A21.51. The pipe shall be cement mortar lined and tar coated in accordance with AWWA C104. Each length of pipe furnished shall be clearly marked to indicate pipe size, pipe class and material designation. Joints for water main installed in open trench shall be mechanical or push-on.

**Installation.** Fire hydrants shall be installed so that the standpipe is plumb. The center of the lowest nozzle shall be placed at least 18 in. but not more than 24 in. above finished grade. The breakable flanges shall be positioned 2 in. above finished grade. The nearest part of the hydrant shall be at least 3 ft. but not more than 8 ft. behind the back of curb. The nearest part of the hydrant shall be at least 3 ft. from all paved surfaces. Where hydrants are to be installed adjacent to a roadway they shall be placed so that the pumper nozzle faces the roadway and is perpendicular to the direction of travel of the roadway. Where hydrants are not to be installed adjacent to a roadway they shall be placed according to the plans or as directed by the Engineer.

Fire hydrants and auxiliary valves shall be set on a firm foundation of precast concrete blocks and shall be thrust blocked. Additional precast concrete bricks shall be placed under the auxiliary valve as needed. Thrust blocking shall consist of Class SI concrete cast in place against the fittings and the undisturbed earth on any side or sides of the excavation where thrust is expected to occur. A minimum of ¼ cu. yd. of concrete shall be used for the thrust blocking. The dimensions of the thrust blocking shall be determined by the Engineer. Thrust blocking may also consist of the placement of precast concrete blocks at the discretion of the Engineer. Additional precast concrete blocks shall be placed on the bottom, back and sides of the hydrant as directed by the Engineer to hold the hydrant

solid and vertical. All blocks, bricks and thrust blocking shall be placed such that the pipe, joints and fittings shall be accessible for future repair and so that the hydrant drain holes are **not blocked**.

Joint restraints shall be installed on all mechanical fittings. Stainless steel threaded tie rods shall be installed between the fire hydrant barrel and the tee fitting on the water main. Barrel extensions will only be permitted at the discretion of the Engineer.

Hydrants shall be braced during backfilling. The area around the base of the hydrant shall be backfilled with a minimum of 1 cu. yd. of washed stone. The washed stone shall be covered with polyethylene sheeting prior to further backfilling. Backfill material shall be placed in lifts not exceeding 6 in. in thickness, loose measurement, and compacted in a manner approved by the Engineer.

Hydrants not in service shall be covered with plastic bags until the hydrants are in service.

Water main piping installed in open trench shall be placed a minimum of 5.5 feet below finished grade or as directed by the Engineer to achieve the necessary clearance from underground utilities or other obstructions.

Considered included in the cost of this item when constructing water main are the following items:

- Construction of water main in "short" tunnels not exceeding five feet in length, past utilities, tree roots, or other obstructions.
- Construction of all required thrust blocking, and other appurtenant work called for by the contract.
- All testing, gas chlorination, sampling, and other work considered incidental as described in the Water and Sewer Specifications. The opening or closing of existing water system valves by contractor to facilitate filling, flushing, testing, etc. shall be done only with the approval and under the supervision of Engineer or Village representative.
- All fittings necessary to make the connections.

All watermain shall be thoroughly flushed and then subjected to a 2 hour pressure and leakage test at 150 PSI by the Contractor and shall be chlorinated in accordance with Village Standards and the Water and Sewer Specifications. Make-up water shall be supplied from an open drum, and the volume of water used shall not exceed that allowed by the Water and Sewer Specifications.

The watermain shall be installed on course aggregate bedding (CA-11) with a minimum thickness of 6 inches. The bedding material shall be placed and compacted to the spring line of the pipe. Blocking of any kind for grade is not permitted.

**Basis of Payment.** This work will be paid for at the contract unit price per each for FIRE HYDRANT WITH AUXILIARY VALVE AND VALVE BOX. Excavation, bedding and backfilling of fire hydrants and ductile iron pipe will not be paid for separately but shall be included in the cost of this work.

#### **PAY ITEM #46 – VALVE VAULTS, TYPE A**

**Description.** This work shall consist of constructing valve vaults with frames and lids as shown in the plans or as directed by the Engineer according to the construction details in the plans and Section 602 of the Standard Specifications, with the following modifications:

In cases where only the valve vault is being replaced and no work is being done to the existing

watermain, the proposed valve vault barrel section shall be of “doghouse” type to fit over existing main. The valve vault base will be a precast base. A continuous layer of non-hardening preformed bituminous mastic material will be used at each joint to prevent inflow. Brick and mortar will be used to close the watermain openings.

**Basis of Payment.** This work will be paid for at the contract unit price per each for VALVE VAULTS, TYPE A, of the diameter specified and with the type of frame and lid specified.

#### **PAY ITEMS #57 & #58 – HOT-MIX ASPHALT DRIVEWAY PAVEMENT**

**Description.** This work shall consist of paving hot-mix asphalt driveway aprons, of the thickness specified, which composition will be of a binder course and surface course as shown in the Hot-Mix Asphalt Mixture Requirements table in the plans and according to Section 406 of the Standard Specifications, with the following modifications:

For an HMA driveway pavement thickness of less than 6”, the aggregate base course, type b will be 6” thick. For an HMA driveway pavement thickness of 6” or more, the aggregate base course, type b will be 8” thick.

Excavation and disposal of materials required to construct the proposed driveway pavement with aggregate base course will be included in this work.

**Method of Measurement.** This work will be measured for payment as follows:

- (a) Contract Quantities. The requirements for the use of contract quantities shall conform to Article 202.07(a) in the Standard Specifications.
- (b) Measured Quantities. Hot-Mix Asphalt Driveway Pavement will be measured for payment in place and the quantity computed in square yards. The width of measurement shall be the width of the top HMA lift as shown on the plans or as directed by the Engineer.

Aggregate base course, excavation and disposal of materials will not be measured for payment but shall be considered as included in the cost of HOT-MIX ASPHALT DRIVEWAY PAVEMENT, of the thickness specified.

**Basis of Payment.** This work will be paid for at the contract unit price per square yard for HOT-MIX ASPHALT DRIVEWAY PAVEMENT, of the thickness specified.

#### **PAY ITEM #60 – DRAINAGE AND UTILITY STRUCTURES TO BE ADJUSTED**

**Description.** This work shall consist of adjusting drainage and utility structures in accordance with Sections 602 and 603 of the Standard Specifications, with the following modifications:

Adjustment will be made with existing frames and grates or lids unless otherwise specified. New frames and grates or lids will be paid for separately according to the Special Provision “Frames, Grates and Lids” described herein.

All drainage and utility structures called off to be adjusted in the plans or as directed by the Engineer shall be reset even if there is no change in final rim elevation.

**Basis of Payment.** This work will be paid for at the contract unit price per each for DRAINAGE & UTILITY STRUCTURES TO BE ADJUSTED.

**PAY ITEM #61 – DRAINAGE AND UTILITY STRUCTURES TO BE RECONSTRUCTED**

**Description.** This work shall consist of reconstructing drainage and utility structures not paid for as adjusted in accordance with Sections 602 and 603 of the Standard Specifications, with the following modifications:

Reconstruction will be made with existing frames and grates or lids unless otherwise specified. New frames and grates or lids will be paid for separately according to the Special Provision “Frames, Grates and Lids” described herein.

Drainage and utility structures requiring reconstruction will also be cleaned by the Contractor. The drainage and utility structures shall be cleaned of silt, debris or other foreign matter of any kind and will be free from such accumulation at the time of final inspection.

**Method of Measurement.** The cleaning of drainage and utility structures, regardless of size, and the removal and disposal of accumulated debris will not be measured for payment separately but shall be considered as included in the cost of this item.

**Basis of Payment.** This work will be paid for at the contract unit price per each for DRAINAGE & UTILITY STRUCTURES TO BE RECONSTRUCTED.

**PAY ITEMS #62 & #63 – STORM SEWER (WATER MAIN REQUIREMENTS)**

**Description.** This work consists of constructing storm sewer of the specified diameter adjacent to or crossing water main, at the locations shown on the plans, meeting the material and installation requirements of the Water and Sewer Specifications, and the applicable portions of Section 550 of the Standard Specifications.

**Materials.** Pipe materials shall meet the requirements of Sections 40 and 41-2.01 of the Water and Sewer Specifications, allowing the use of both polyvinyl chloride (PVC) pipe and ductile iron pipe. If ductile iron pipe is used, it shall meet the minimum requirements for Thickness Class 52.

If PVC pipe is used, it shall have a Standard Dimension Ratio (SDR) of 26 conforming to ASTM D2241 with gasket joints conforming to ASTM D3212. All supplied pipes and fittings must be from the same manufacturer. Connections to existing sewer lines shall be made using non-shear Fernco RC Series or Mission Flex-Seal adjustable repair couplings equipped with stainless steel bands.

Encasing (with seals) of standard type storm sewer, in accordance with the details for “Water and Sewer Separation Requirements (Vertical Separation)”, (DIV. V/STANDARD DRAWINGS) in the Water and Sewer Specifications, may be used for storm sewers crossing water mains with prior approval from the Engineer.

**Basis of Payment.** This work will be paid for in accordance with Article 550.10 of the Standard Specifications, except the pay item shall be STORM SEWER (WATER MAIN REQUIREMENTS), of the diameter specified.

**PAY ITEM #64 – SAWING P.C. CONCRETE PAVEMENT (FULL DEPTH)**

**Description.** This work shall consist of providing full-depth saw cuts to create a new edge-of-pavement in concrete pavements with monolithic curb. The saw cuts will be made as shown on the plans and as directed by the Engineer according to applicable portions of Section 442 of the Standard Specifications, with the following modifications:

The Contractor will only be paid once to satisfactorily complete the full-depth saw cuts according to the dimensions and lengths shown on the plans. Any additional work needed to create a new edge-of-pavement will not be paid for separately but shall be included in the cost of this item. Any damage done to areas outside of this work due to Contractor's negligence will be repaired or replaced in kind at Contractor's own expense.

**Method of Measurement.** Full-depth saw cuts will only be measured for payment in creating a new edge-of-pavement in concrete pavements with monolithic curb. Full-depth saw cuts will be measured for payment in place in feet. Saw cuts will not be measured for other removal operations, but shall be included in the item being removed.

**Basis of Payment.** This work will be paid for at the contract unit price per foot for SAWING P.C. CONCRETE PAVEMENT (FULL DPETH).

**PAY ITEM #65 – TOPSOIL FURNISH AND PLACE, 4" (SPECIAL)**

**Description.** This work shall be performed in accordance with Section 211 of the Standard Specifications, with the following modifications:

The nominal depth of topsoil to be furnished and placed is 4". Variations in depth may exist throughout the project area which may require a larger or smaller depth of topsoil depending on the final grading conditions. Where applicable, the Contractor shall grade the disturbed parkway such that it positively drains towards the roadway.

**Method of Measurement.** Topsoil furnish and place, regardless of variations in depth, will be measured in square yards.

**Basis of Payment.** This work will be paid for at the contract unit price per square yard for TOPSOIL FURNISH AND PLACE, 4" (SPECIAL).

**PAY ITEM #66 – EXPLORATION TRENCH, SPECIAL**

**Description.** This work shall consist of constructing a trench for the purpose of locating and inspecting an existing utility or utilities. This work shall be in accordance with Section 213 of the Standard Specifications, except as modified herein.

The exploration trench may be used to locate any existing utility or utilities, including, but not limited to, water mains, water services, sewer mains, sewer services, field tiles, gas lines, underground electric lines, underground telephone lines, underground cable TV lines, underground communication lines, underground fiber optic lines, and other utilities as applicable.

The exploration trench may be used to locate existing utilities regardless of whether the utilities are public or private; known or unknown; or marked or unmarked. The exploration trench may also be used to inspect the condition of existing utilities, determine the material type or dimensions of existing utilities, and to verify clearances between multiple utilities.

The exploration trench shall be constructed at the locations shown on the plans or as directed by the Engineer. The depth of the exploration trench shall vary as necessary, but shall be sufficient to locate the utility or utilities under investigation. The width of the trench shall be sufficient to allow proper investigation of the entire trench.

Upon completion of the exploration trench, the trench shall be backfilled. All exploration trenches where the inner edge of the trench is within 2 ft of an existing or proposed edge of pavement, driveway, curb, gutter, curb and gutter, stabilized shoulder, or sidewalk shall be backfilled with trench backfill in accordance with Section 208 of the Standard Specifications. Exploration trenches which do not require trench backfill shall be backfilled in accordance with Article 550.07 of the Standard Specifications. Backfilling of exploration trenches will not be measured for payment but shall be included in the cost of this work.

**Method of Measurement.** The exploration trench will be measured for payment in feet of actual trench constructed, regardless of the depth of the trench constructed. No additional measurement or compensation will be allowed for any delays or unforeseen circumstances arising from this work.

**Basis of Payment.** This work will be paid for at the contract unit price per foot for EXPLORATION TRENCH, SPECIAL.

#### **PAY ITEM #67 – SODDING, SPECIAL**

**Description.** This work shall be performed in accordance with Section 252 of the Standard Specifications, with the following modifications:

Nitrogen fertilizer and potassium fertilizer will be used as specified in Article 252.03 of the Standard Specifications. Phosphorus fertilizer will not be used due to its negative environmental impacts.

**Method of Measurement.** Fertilizer will not be measured for payment but shall be considered as included in the cost of SODDING, SPECIAL.

**Basis of Payment.** This work will be paid for at the contract unit price per square yard for SODDING, SPECIAL.

#### **PAY ITEM #68 – TEMPORARY ACCESS (DRIVEWAY ENTRANCE)**

**Description.** This work shall consist of constructing and maintaining an aggregate surface course for temporary access to driveway entrances according to Article 402.07 and other applicable portions of Section 402 of the Standard Specifications, with the following modifications:

The aggregate surface course shall be constructed to the dimensions and grades specified below, except as modified by the plans or as directed by the Engineer. The Engineer will be the sole judge in determining the appropriate use of these items. The Contractor will need approval from the Engineer

prior to the placement of any aggregate for temporary access described below.

- (a) Driveway Entrance. The minimum width shall be 12 feet. The minimum compacted thickness shall be 6 inches. The maximum grade shall be eight percent, except as required to match the existing grade.

Maintaining the temporary access shall include relocating and/or re-grading the aggregate surface course for any operation that may disturb or remove the temporary access. The same type and gradation of material used to construct the temporary access shall be used to maintain it.

When use of the temporary access is discontinued, the aggregate shall be removed and utilized in the permanent construction or disposed of according to Article 202.03.

**Method of Measurement.** Aggregate surface course for temporary access will be measured for payment as each for every driveway entrance constructed for the purpose of temporary access. If a driveway entrance is to be constructed under multiple stages, the aggregate needed to construct the second or subsequent stages will not be measured for payment but shall be included in the cost per each of the type specified.

**Basis of Payment.** Aggregate surface course used for temporary access will be paid for at the contract unit price per each for TEMPORARY ACCESS (DRIVEWAY ENTRANCE).

Partial payment of the each amount bid for this item will be paid according to the following schedule:

- (a) Upon construction of the temporary access, sixty percent of the contract unit price per each of this item will be paid.
- (b) Subject to the approval of the Engineer for the adequate maintenance and removal of the temporary access, the remaining forty percent of the pay item will be paid upon the permanent removal and disposal of the temporary access.
- (c) If the Contractor chooses to re-use the aggregate for temporary access in the permanent construction of the proposed items specified in the contract, the Contractor will forfeit partial payment of the remaining forty percent. Instead, the Contractor will be paid for the permanent construction work using the proposed pay items for the specified work.

#### **PAY ITEM #69 –TEMPORARY ACCESS (ROAD)**

**Description.** This work shall consist of constructing and maintaining an aggregate surface course for temporary access to roads according to Article 402.07 and other applicable portions of Section 402 of the Standard Specifications, with the following modifications:

The aggregate surface course shall be constructed to the dimensions and grades specified below, except as modified by the plans or as directed by the Engineer. The Engineer will be the sole judge in determining the appropriate use of these items. The Contractor will need approval from the Engineer prior to the placement of any aggregate for temporary access described below.

- (a) Road. The minimum width shall be 24 feet. The minimum compacted thickness shall be 9 inches. The grade and elevation shall be the same as the removed pavement, except as required to meet the grade of any new pavement constructed.

Maintaining the temporary access shall include relocating and/or re-grading the aggregate surface course for any operation that may disturb or remove the temporary access. The same type and gradation of material used to construct the temporary access shall be used to maintain it.

When use of the temporary access is discontinued, the aggregate shall be removed and utilized in the permanent construction or disposed of according to Article 202.03.

**Method of Measurement.** Aggregate surface course for temporary access will be measured for payment as each for every road constructed for the purpose of temporary access. If a road is to be constructed under multiple stages, the aggregate needed to construct the second or subsequent stages will not be measured for payment but shall be included in the cost per each of the type specified.

**Basis of Payment.** Aggregate surface course used for temporary access will be paid for at the contract unit price per each for TEMPORARY ACCESS (ROAD).

Partial payment of the each amount bid for this item will be paid according to the following schedule:

- (a) Upon construction of the temporary access, sixty percent of the contract unit price per each of this item will be paid.
- (b) Subject to the approval of the Engineer for the adequate maintenance and removal of the temporary access, the remaining forty percent of the pay item will be paid upon the permanent removal and disposal of the temporary access.
- (c) If the Contractor chooses to re-use the aggregate for temporary access in the permanent construction of the proposed items specified in the contract, the Contractor will forfeit partial payment of the remaining forty percent. Instead, the Contractor will be paid for the permanent construction work using the proposed pay items for the specified work.

#### **PAY ITEMS #70 & #71 – PORTLAND CEMENT CONCRETE DRIVEWAY PAVEMENT**

**Description.** This work shall consist of constructing portland cement concrete (PCC) driveway pavement, of the thickness specified, on a prepared aggregate base as shown in the plans or as directed by the Engineer according to Sections 351 and 423 of the Standard Specifications, with the following modifications:

For a PCC driveway pavement thickness of less than 8", the aggregate base course, type b will be 4" thick. For a PCC driveway pavement thickness of 8" or more, the aggregate base course, type b will be 6" thick.

Excavation and disposal of materials required to construct the proposed driveway pavement with aggregate base course will be included in this work.

**Method of Measurement.** Aggregate base course, excavation and disposal of materials will not be measured for payment but shall be considered as included in the cost of PORTLAND CEMENT CONCRETE DRIVEWAY PAVEMENT, of the thickness specified, SPECIAL.

**Basis of Payment.** This work will be paid for at the contract unit price per square yard for

PORTLAND CEMENT CONCRETE DRIVEWAY PAVEMENT, of the thickness specified, SPECIAL.

#### **PAY ITEMS #72 & #73 – PORTLAND CEMENT CONCRETE SIDEWALK**

**Description.** This work shall consist of constructing portland cement concrete (PCC) sidewalk, of the thickness specified, on a prepared aggregate base as shown in the plans or as directed by the Engineer according to Sections 351 and 424 of the Standard Specifications, with the following modifications:

All constructed sidewalk shall comply with the slope and grade tolerances specified in the construction details shown in the plans and according to the latest edition of the Public Right-of-Way Accessibility Guidelines (PROWAG). The extent of sidewalk replacement shown in the plans at roadway intersections is approximate. The final limits of sidewalk replacement will be determined by the Engineer in the field in order to comply with the slopes and grades dictated by PROWAG. This work shall include re-grading, excavation and disposal of materials as directed by the Engineer to conform to these accessibility guidelines.

For a PCC sidewalk thickness of less than 8", the aggregate base course, type b will be 4" thick. For a PCC sidewalk thickness of 8" or more, the aggregate base course, type b will be 6" thick.

When constructing PCC sidewalk through a residential driveway entrance, the thickness of the PCC sidewalk shall be 6" regardless of the actual thickness called off by the plan pay item.

Excavation and disposal of materials required to construct the proposed sidewalk with aggregate base course will be included in this work.

**Method of Measurement.** Aggregate base course, excavation and disposal of materials will not be measured for payment but shall be considered as included in the cost of PORTLAND CEMENT CONCRETE SIDEWALK, of the thickness specified, SPECIAL. The increase in sidewalk thickness to 6" through a residential driveway entrance will not be measured for payment but shall be considered as included in the cost of PORTLAND CEMENT CONCRETE SIDEWALK 5 INCH, SPECIAL.

**Basis of Payment.** This work will be paid for at the contract unit price per square foot for PORTLAND CEMENT CONCRETE SIDEWALK, of the thickness specified, SPECIAL.

#### **PAY ITEM #74 – PORTLAND CEMENT CONCRETE SURFACE REMOVAL (VARIABLE DEPTH)**

**Description.** This work shall consist of the removal of portland cement concrete (PCC) surfaces in preparation for subsequent hot-mix asphalt (HMA) resurfacing as shown in the plans or as directed by the Engineer according to Section 440 of the Standard Specifications, with the following modifications:

The nominal removal depth shall be an edge grind varying between 2 inches and 0 inches. Additional variations in grinding may occur depending on field conditions. No additional compensation will be provided for these varying conditions.

**Method of Measurement.** This work will be measured for payment as follows:

- (a) Contract Quantities. The requirements for the use of contract quantities shall conform to Article 202.07(a) in the Standard Specifications.

- (b) Measured Quantities. PCC surface removal will be measured for payment in place and the area computed in square yards. The square yards measured will be paid for only once, regardless of the number of passes required to remove the material. The width shall be as shown on the plans or as directed by the Engineer.

Removal of PCC surface outside the designated limits as shown on the plans or as directed by the Engineer will not be measured for payment. Areas damaged outside these limits will be repaired at Contractor's own expense.

**Basis of Payment.** This work will be paid for at the contract unit price per square yard for PORTLAND CEMENT CONCRETE SURFACE REMOVAL (VARIABLE DEPTH).

### **PAY ITEM #75 – HOT-MIX ASPHALT SURFACE REMOVAL, VARIABLE DEPTH**

**Description.** This work shall consist of the removal of hot-mix asphalt (HMA) surfaces in preparation for subsequent resurfacing as shown in the plans or as directed by the Engineer according to Section 440 of the Standard Specifications, with the following modifications:

The nominal removal depth is shown on the plans for the various roadways. In certain situations, the Engineer may vary the HMA surface removal depth from 0" (MIN.) to 4" (MAX.) to remove irregularities and imperfections in the roadway cross-slope and profile.

In composite sections consisting of a HMA surface pavement over a portland cement concrete (PCC) base pavement, the minimum HMA surface removal shall be 2". Under no condition will there be less than 2" of material removal, even if it requires the Contractor to remove some of the PCC base pavement. Grinding of PCC pavement overlaid by HMA pavement will be included in the cost of this item.

**Method of Measurement.** This work will be measured for payment as follows:

- (c) Contract Quantities. The requirements for the use of contract quantities shall conform to Article 202.07(a) in the Standard Specifications.
- (d) Measured Quantities. HMA surface removal will be measured for payment in place and the area computed in square yards. The square yards measured will be paid for only once, regardless of the number of passes required to remove the material. The width shall be as shown on the plans or as directed by the Engineer.

Removal of HMA surface outside the designated limits as shown on the plans or as directed by the Engineer will not be measured for payment. Areas damaged outside these limits will be repaired at Contractor's own expense. Adjustment of quantities will not be allowed should the Engineer choose to vary the depth of surface removal. Additional compensation will not be allowed if PCC base pavement is encountered during the surface removal process.

**Basis of Payment.** This work will be paid for at the contract unit price per square yard for HOT-MIX ASPHALT SURFACE REMOVAL, VARIABLE DEPTH.

**PAY ITEM #76 – PAVEMENT REMOVAL (SPECIAL)**

**Description.** This work shall consist of the removal of existing hot-mix asphalt (HMA) pavement and portland cement concrete (PCC) pavement as shown in the plans or as directed by the Engineer according to Section 440 of the Standard Specifications, with the following modifications:

Pavement cores have been taken along most of the roadways and the results have been included in the contract documents. When developing cross sections and earthwork excavation calculations, an average existing pavement thickness was assumed for the following reconstruction roadways and site plans which include HMA pavements, PCC pavements, and composite pavements:

Adams Street – 2” HMA over 7” PCC pavement (9” composite pavement)  
Grant Avenue – 3.75” HMA pavement  
Cross Street – 3.5” HMA pavement  
Sunset Drive – 6” PCC pavement  
Harvard Avenue (dead end) – 3” HMA pavement  
Belden Avenue – 0” pavement  
Washington Street – 3” HMA pavement  
Golf Course Parking Lot – 3” HMA pavement

These will be the pavement depths for this item regardless of actual depth encountered in the field. When removing the existing pavements, any further excavation beyond the assumed pavement depths listed above to reach the proposed subgrade shall be considered as excavation under the Special Provision “Earthwork” described herein. If more pavement is encountered beyond what is assumed above, the removal shall be considered as EARTH EXCAVATION. If less pavement is encountered than what is assumed above, that difference shall be considered as PAVEMENT REMOVAL (SPECIAL).

All pavement removal areas shall be saw cut full depth along their perimeter prior to the removal of pavement. The use of drop hammers will not be allowed for breaking these pavements.

**Method of Measurement.** This work will be measured for payment in place and the area computed in square yards. Removal of pavement outside the designated limits as shown on the plans or as directed by the Engineer will not be measured for payment. Areas damaged outside these limits will be repaired at Contractor’s own expense. Adjustment of quantities will not be allowed if actual pavement depths vary from what was assumed above.

**Basis of Payment.** This work will be paid for at the contract unit price per square yard for PAVEMENT REMOVAL (SPECIAL).

**PAY ITEM #77 – VALVE BOXES TO BE ADJUSTED (SPECIAL)**

**Description.** This work shall consist of adjusting valve boxes to the finished grade as shown in the plans or as directed by the Engineer according to Section 602 of the Standard Specifications, with the following modifications:

If the Contractor is unable to adjust the valve box to the final grade, the Contractor shall remove the existing valve box and install a new valve box similar in material and size. The Contractor will make sure the new valve box will be able to fit over the existing water valve and have the ability to adjust to the final grade.

The Engineer will review the condition of the old valve box to determine if it should be returned to the Village or disposed of by the Contractor. If the Engineer deems it salvageable, the Contractor shall deliver the old valve box to the Public Works Department Yard at 51 South Ardmore Avenue. Otherwise, the Contractor shall appropriately dispose of the valve box.

**Method of Measurement.** This work will be measured for payment in units of each valve box adjusted. If the valve box is unable to be adjusted, the occurrence of removing the old valve box and installing a new valve box will collectively be measured for payment in units of each occurrence. The delivery of old valve box to the Public Works Department Yard or disposal of old valve box will not be measured for payment but shall be considered as included in the cost of this item.

**Basis of Payment.** This work will be paid for at the contract unit price per each for VALVE BOXES TO BE ADJUSTED (SPECIAL).

#### **PAY ITEM #78 – CONCRETE CURB (SPECIAL)**

**Description.** This work shall consist of constructing a special concrete curb to replace the existing curb shown in the plans or as directed by the Engineer. This work shall be done in accordance with Section 606 of the Standard Specifications, with the following modifications:

Before removing the old curb, the Contractor shall retrieve the existing curb's dimensions in order to replace the curb in kind. In areas where the curb will be constructed in a new location, the same dimensions will be used for construction except that the height will not exceed 18 inches above the finished grade of the pavement. Re-grading the landscaped area behind the curb in certain locations may be necessary as directed by the Engineer. Any concrete curb transitions between existing or proposed curb required by the Engineer will be included in the work of this item. The subgrade will be prepared with 6" of aggregate base course, type b, before constructing the concrete curb.

Excavation and disposal of materials required to construct the proposed concrete curb with aggregate base course will be included in this work.

**Method of Measurement.** Aggregate base course, re-grading of landscaped areas, excavation and disposal of materials will not be measured for payment but shall be considered as included in the cost of this item. Removal of the existing curb will be measured for payment in feet. The measurement for curb removal will be made along the face of the curb.

**Basis of Payment.** This work will be paid for at the contract unit price per foot for CONCRETE CURB (SPECIAL). Removal of the existing curb will be paid for at the contract unit price per foot for COMBINATION CURB AND GUTTER REMOVAL.

#### **PAY ITEM #79 – COMBINATION CONCRETE CURB AND GUTTER, TYPE B-6.12 (SPECIAL)**

**Description.** This work shall consist of constructing combination concrete curb and gutter on a prepared aggregate base as shown on the plans or as directed by the Engineer. This work shall be done in accordance with Sections 351 and 606 of the Standard Specifications, Standard No. 606001 and the construction details shown in the plans, with the following modifications:

Combination concrete curb and gutter shall be constructed on 4" (minimum) of aggregate base

course, type b. Only forms made of wood shall be used. Forms constructed of steel or Masonite will not be permitted. Forms for radius sections of the combination concrete curb and gutter shall be constructed on 1-inch thick wood boards.

Depressed curb for alleys, driveway openings, sidewalk ramps accessible to the disabled, and any other designated areas shall be constructed at the locations shown on the plans or as directed by the Engineer. There may be certain areas of curb and gutter that have depressed curbs in locations that do not warrant such depressions. The Engineer may decide in the field to replace these locations to a barrier curb and gutter. The transition from full height curb to depressed curb shall be made over a distance equal to at least four times the difference in height between the full height curb and the depressed curb. Any variations in curb height, gutter width, or other modifications to meet or alter existing conditions will be included in the cost of this item.

When combination concrete curb and gutter is constructed across sidewalk curb ramps, the depressed curb height and gutter slope shall be in accordance with the Public Right-of-Way Accessibility Guidelines (PROWAG).

Where combination concrete curb and gutter is to be constructed adjacent to existing pavement that is not being reconstructed, the Contractor will be required to saw cut 6 inches off the edge-of-pavement. The saw cut and removal of existing 6" wedge will be included in the cost of this item. The void between the existing pavement and the proposed combination concrete curb and gutter shall be filled in with a concrete wedge with a minimum width of 6 inches and a minimum thickness of 8 inches. The concrete wedge shall be placed after the combination concrete curb and gutter has been placed and the forms have been removed. The placement of the concrete wedge will not be paid for separately but shall be included in the cost of this item.

Concrete curing methods shall be limited to the methods specified in Article 1020.13 (a) (1), (2), and (3) of the Standard Specifications. Expansion joints shall be constructed at 60 ft. maximum centers. Expansion joints shall also be constructed at all construction joints, all points of curvature, all points of tangency, within 5' on either side of all curb structure castings, and at additional locations as directed by the Engineer. Expansion joints shall consist of a 1 in. thick preformed bituminous expansion joint filler that extends the full cross section of the combination concrete curb and gutter. Expansion joint filler material that is larger than the cross section of the combination concrete curb and gutter shall be cut to the exact cross section of the combination concrete curb and gutter. Expansion joints shall have two 18 in. long, No. 6 non-deformed epoxy-coated steel dowel bars placed at mid-depth. The dowel bars shall have a greased plastic expansion cap placed on one end of each dowel bar a minimum of 1 in. from the end of the dowel bar.

Where proposed combination concrete curb and gutter is to be constructed abutting existing combination concrete curb and gutter, the dowel bars shall be drilled into the existing combination concrete curb and gutter. This work will not be paid for separately but shall be included in the cost of this item.

Contraction joints shall be constructed at 15 ft. maximum centers. Where the location of a contraction joint coincides with the location of an expansion joint, the contraction joint may be omitted at the discretion of the Engineer. Contraction joints shall be tooled and sawed. Sawing of contraction joints shall commence as soon as the concrete has hardened sufficiently to permit sawing without excessive raveling, but in no case shall sawing commence less than 4 hours or more than 24 hours after the concrete is placed. Sawing of contraction joints shall be to a depth equal to 1/3 the thickness of the gutter flag and to a width of not less than 1/8 in. Contraction joints shall be sealed according to Article 420.12, except that joints shall be sealed with polysulfide or polyurethane joint sealant.

If Contractor fails to construct joints in accordance with the requirements of this provision and the curb cracks, the Contractor shall remove and replace the affected section of combination concrete curb and gutter extending the full length between the two adjacent joints on either side of the crack. This work will not be paid for separately but shall be at the Contractor's own expense.

Upon removal of the forms from the back of the combination concrete curb and gutter, excavated areas behind the combination concrete curb and gutter shall be immediately backfilled. Areas where pavement or sidewalks are to be constructed shall be backfilled with crushed aggregate of CA-6 or CA-7 gradation and mechanically compacted. Areas where topsoil and sodding are to be placed shall be backfilled with non-organic material acceptable to the Engineer. This work will not be paid for separately but shall be included in the cost of this item.

**Method of Measurement.** Aggregate base course will not be measured for payment but shall be considered as included in the cost of this item. Excavation and disposal of materials required in the performance of the work will not be measured for payment but shall be considered as included in the cost of this item.

**Basis of Payment.** This work will be paid for at the contract unit price per foot for CONBINATION CONCRETE CURB AND GUTTER, TYPE B-6.12 (SPECIAL).

#### **PAY ITEM #80 – TRAFFIC CONTROL AND PROTECTION, (SPECIAL)**

**Description.** This item of work shall include furnishing, installing, maintaining, replacing, relocating and removing all traffic control devices used for the purpose of regulating, warning or directing traffic during construction or maintenance of this improvement.

Traffic Control and Protection shall be provided as called for in the Plans, these Special Provisions, applicable Highway Standards, and applicable sections of the Standard Specifications.

The governing factor in the execution and staging of work for this project is to provide the motoring public and pedestrian public with the safest possible travel conditions through the construction zone.

All traffic control devices used on this project shall conform to the Plans, Special Provisions, Traffic Control Standards, Traffic Specifications and the "Illinois Manual on Uniform Traffic Control Devices for Streets and Highways" (MUTCD).

Traffic Control Devices include signs and their supports, signals, pavement markings, barricades with sand bags, channelizing devices, warning lights, arrowboards, flaggers, or any other device used for the purpose of regulating, detouring, warning or guiding traffic through or around the construction zone.

Only signs, barricades, vertical panels, drums and cones that meet the requirements of the Department's "Quality Standard for Work Zone Traffic Control Devices - 1998" shall be used on this project. Copies of this publication are available from the Bureau of Traffic for the Contractor's use prior to the initial set-up. At the time of the initial set-up or at the time of major stage changes, 100 percent of each type of device (cones, drums, barricades, vertical panels or signs) shall be acceptable as defined by the referenced publication. Throughout the duration of the project, the percentage of acceptable devices may decrease to 75 percent only as a result of damage and/or deterioration during the course of work. Work shall not begin until a determination has been made that the traffic control

devices meet the quality required in this standard.

The Contractor is required to conduct routine inspections of the worksite at a frequency that will allow for the prompt replacement of any traffic control device that has become displaced, worn or damaged to the extent that it no longer conforms to the shape, dimensions, color and operational requirements of the MUTCD, the Traffic Control Standards or will no longer present a neat appearance to motorists. A sufficient quantity of replacement devices, based on vulnerability to damage, shall be readily available to meet this requirement.

The Contractor shall be responsible for the proper location, installation and arrangement of all traffic control devices. Special attention shall be given to advance warning signs during construction operations in order to keep lane assignment consistent with barricade placement at all times. The Contractor shall immediately remove, cover or turn from the view of the motorists all traffic control devices which are inconsistent with detour or lane assignment patterns and conflicting conditions during the transition from one construction stage to another. When the Contractor elects to cover conflicting or inappropriate signing materials used shall totally block out reflectivity of the sign and shall cover the entire sign. The method used for covering the signing shall meet with the approval of the Engineer.

When directed by the Engineer, the Contractor shall remove all traffic control devices which were furnished, installed and maintained by him under this contract, and such devices shall remain the property of the Contractor. All traffic control devices shall remain in place until specific authorization for relocation or removal is received from the Engineer.

The Contractor shall ensure that all traffic control devices installed by him are operational, functional and effective 24 hours a day, including Sundays and holidays.

**Signs.** All signs except those referring to daily lane closures shall be post mounted in accordance with Standard 720001 for all projects that exceed four days.

Construction signs referring to daytime lane closures during working hours shall be removed, covered or turned away from the view of the motorists during non-working hours.

Prior to the beginning of construction operations, the Contractor will be provided a sign log of all existing signs within the limits of the construction zone. The Contractor is responsible for verifying the accuracy of the sign log. Throughout the duration of this project, all existing traffic signs shall be maintained by the Contractor. All provisions of Article 107.25 of the Standard Specifications shall apply except the third paragraph shall be revised to read: "The Contractor shall maintain, furnish and replace at his own expense, any traffic sign or post which has been damaged or lost by the Contractor or a third party. The Contractor will not be held liable for third party damage to large freeway guide signs".

"Fresh Oil" signs (W21-2) shall be used when prime is applied to pavement that is open to traffic. The signs are to remain until tracking of the prime ceases. The sign shall be erected a minimum of 500 feet preceding the start of prime on all side roads within the posted area. The "Fresh Oil" sign on the side road shall be posted a minimum of 200 feet from the mainline pavement.

"Rough Grooved Surface" signs (W8-I107) shall be used when the road has been cold milled and open to traffic. The signs shall remain in place until the milled surface condition no longer exists. These signs shall be erected a minimum of 500 feet preceding the start of the milled pavement and on all side roads within the posted area. The "Rough Grooved Surface" signs on the side roads shall be

posted 200 feet from the mainline pavement. All signs shall have an 18" x 18" orange flag and an amber flashing light attached.

**Placement and Removal of Signs and Barricades.** Placement of all signs and barricades shall proceed in the direction of flow of traffic. Removal of all signs and barricades shall start at the end of the construction areas and proceed toward oncoming traffic unless otherwise directed by the Engineer.

**Public Safety and Convenience.** The Contractor shall provide the Engineer a telephone number where a responsible individual can be contacted on a 24-hour-a-day basis to receive notification of any deficiencies regarding traffic control and protection. The Contractor shall dispatch men, materials and equipment to correct any such deficiencies. The Contractor shall respond to any call from the Engineer concerning any request for improving or correcting traffic control devices and begin making the requested repairs within two hours from the time of notification.

When traveling in lanes open to public traffic, the Contractor's vehicle shall always move with and not against or across the flow of traffic. These vehicles shall enter or leave work areas in a manner which will not be hazardous to, or interfere with, traffic and shall not park or stop except within designated work areas. Personal vehicles shall not park within the right of way except in specific areas designated by the Engineer.

**Method of Measurement.** This item of work will be measured on a lump sum basis for furnishing, installing, maintaining, replacing, relocating and removing traffic control devices as specified in the Plans and these Special Provisions.

**Basis of Payment.** This work will be paid for at the contract lump sum price for TRAFFIC CONTROL AND PROTECTION, (SPECIAL); which price shall be payment in full for all labor, materials, transportation, handling and incidentals necessary to furnish, install, maintain, replace, relocate and remove all traffic control devices indicated in the plans and specifications and as required by the Engineer. The salvage value of the materials removed shall be reflected in the bid price for this item.

Delays to the Contractor caused by complying with these requirements will be considered incidental to the item for Traffic Control and Protection, and no additional compensation will be allowed.

The lump sum bid price for TRAFFIC CONTROL AND PROTECTION, (SPECIAL) shall not exceed 5% of the total bid price.

#### **PAY ITEM #81 – CONNECTION TO EXISTING WATER MAIN (NON PRESSURE)**

**Description.** This work shall consist of making non-pressure, cut-in connections of new water main and fire hydrant leads to existing water main. It shall be performed in accordance with applicable portions of Section 41 of the Water and Sewer Specifications, with the following clarifications:

**Materials.** Water main and fittings shall conform to the Special Provision "Fire Hydrant with Auxiliary Valve and Valve Box". The work includes a material allowance of 15 linear feet of ductile iron pipe (of the necessary diameter) and all fittings necessary to make the connection. Trench backfill shall meet the requirements for CA-6 listed in Article 1004.01 of the Standard Specifications.

Couplings shall be Krausz Hymax Grip coupling restraints (of the necessary diameter), or approved equal.

**Connection Requirements.** New water main shall be connected to existing water main after the new main has passed hydrostatic testing and disinfection. Connections shall be accomplished by the use of mechanical joint fittings and lengths of pipe to make the most direct vertical and horizontal adjustments necessary to complete the connection. This may include cut-ins to the existing main or connections to existing valves or fittings. This work will require water to be shut off, which shall be coordinated with the Village's maintenance personnel providing a minimum of 48 hours notice to the Village.

**Basis of Payment.** This work will be measured and paid for at the contract unit price per each for CONNECTION TO EXISTING WATER MAIN (NON PRESSURE) which price shall include all labor, equipment, ductile iron pipe water main (up to 15 linear feet), all water main fittings, disinfection, testing, excavation, bedding, backfill and thrust blocking required to make the connection.

### **PAY ITEM #82 – PRECONSTRUCTION VIDEO TAPING**

**Description.** This work consists of performing color video and audio recording of the project area and other areas which may be impacted by construction.

Preconstruction video recordings will include coverage of the project area and all other areas which may be impacted by construction. Video recordings will also include construction easements when applicable. Video recordings will provide a visual record of all physical features within those areas, including, but not limited to, roadways, pavements, curbs, gutters, driveways, driveway aprons, sidewalks, carriage walks, parkways, trees, landscaping, shrubbery, plantings, landscaping walls, retaining walls, fences, utility poles, light poles, utilities, manholes, b-boxes, cleanouts, valves, curb structures, pipelines, buildings, mailboxes, and any other features located within the project area.

Video recordings will begin with an audio narrative which provides the current date and time, the name of Owner and name of project, and a description of both the starting location and the location or locations to be recorded, including street name or names, street addresses, and any additional information which may be necessary to describe the location and subject of viewing.

Video recordings will maintain viewer orientation by means of an audio commentary in the audio track of each video recording which provides an explanation of what is being viewed; and by videotaping landmarks and readily identifiable objects (property addresses, street signs, etc.) at appropriate intervals.

Preconstruction video recordings will be recorded at a rate of travel not exceeding 48 feet per minute, and zooming and panning rates will be controlled to provide clarity of features during playback. The finished product will be provided with bright, clear pictures and accurate colors free from distortion, tearing, rolls, or other forms of picture imperfection. The audio will have proper volume and clarity. All recordings will be performed at times of satisfactory visibility, and when no more than ten percent of ground is obscured by snow, leaves, or other cover.

If any element within or portion of the project area is not adequately documented by the preconstruction video recording so as to definitively demonstrate its condition prior to the start of construction, Contractor will assume responsibility for the repair, restoration or replacement of that element or portion of the project area. Such repair, restoration or replacement will be to equal or better condition than previously existing, and will further comply with all standards and provisions which govern the work in question.

**Schedule.** Preconstruction video recording will be performed according to the following schedule:

- (a) Preconstruction video recording will take place after a Notice to Proceed has been issued.
- (b) Preconstruction video recording will take place after the Joint Utility Locating Information for Excavators (JULIE) request for the project area has cleared.
- (c) Preconstruction video recording will take place before any equipment, materials, or other items are delivered to the site.
- (d) Preconstruction video recording will take place no more than seven (7) chargeable days prior to the start of construction.
- (e) Preconstruction video recording will take place, the required pre-construction video recording deliverables will be submitted to the Engineer, and the Engineer will review and issue written approval of the video before any activity other than utility locating will be permitted to start. Such activity will include, but not be limited to, delivery of materials and equipment, installation of traffic control and erosion control, and completion of construction layout and tree protection. No days will be charged against the contract time while the video is under review by the Engineer, including the day the deliverables are submitted and the day a response is provided. If the video or any portions thereof are rejected, the contract time will commence to run until revisions are submitted.
- (f) The recording will be submitted to Engineer for review prior to commencement of any construction, and receive acceptance of recordings prior to commencement of construction. Any areas found not acceptable to the Owner will be re-filmed at no additional cost to the contract. The final recording shall be transferred onto DVD and both the DVD and video recording shall be presented in a manner acceptable to the Owner.

**Deliverables.** Video will be high-definition, with a minimum resolution of 1280 x 720 pixels per frame. Video will be filmed in a landscape aspect ratio. Video filmed in a portrait aspect ratio will be considered unacceptable and will be rejected.

Preconstruction video recordings will be provided as electronic files of .avi, .mp4, .m4v, .mkv, .wmv, or .mpg file format, or of such other file format as may be approved by Engineer. Preconstruction video recordings will be provided as independent digital container format files, which container files will include all video, audio, and other electronic information necessary to view the preconstruction video recording as intended.

Video DVD will be considered an unacceptable format for providing preconstruction video recordings, and will be rejected.

Preconstruction video recording electronic files will be provided on a portable electronic media device or devices of one of the following types: USB flash drive, SD flash memory card, CF flash memory card, data DVD, external hard drive, or such other portable electronic media device as may be approved by Engineer. Preconstruction video recording electronic files may also be provided via online file sharing, cloud storage, File Transfer Protocol (FTP), or other online or network file transfer methods if approved by Engineer.

Preconstruction video recording electronic files will be accompanied by corresponding logs which

document the dates, times, and locations covered by each preconstruction video recording electronic file.

Contractor shall maintain copies of all items submitted to Engineer for Contractor's own use and record.

**Method of Measurement.** This work will be measured for payment on a lump sum basis. No measurement will be made of the individual components of this effort.

**Basis of Payment.** Preconstruction video recording will be paid for at the contract lump sum price for PRECONSTRUCTION VIDEO TAPING.

### **PAY ITEM #83 – SANITARY SEWER CLEAN OUT**

**Description.** This work shall consist of constructing new sanitary sewer clean outs on new and existing sanitary sewer services at locations shown on the plans, and at other locations as deemed necessary by the Engineer. This work shall be done in conjunction and accordance with the Special Provision "Sanitary Sewer Repair, Remove and Replace", as specified herein.

The clean out shall be installed on top of a new tee fitting located on the service line. The clean out shall match the required sanitary sewer service diameter of 6". Two "T" bolts shall be secured to the cap even with the top of the cap. The final rim elevation of the clean outs shall be adjusted to the finished grade.

The location of the clean out designates the transition between the proposed sanitary service line and the existing sanitary service line. The existing service line may be of a different material or diameter. All fittings and adapters necessary to assemble the clean out and connect the clean out to the existing service line shall be included in this item.

**Materials.** Service tee and clean out riser shall be polyvinyl chloride (PVC) pipe with a Standard Dimension Ratio (SDR) of 26 conforming to ASTM D2241. The Contractor shall use P1215 DWV bushing and G106 gasketed cap manufactured by Plastic Trends, Inc. (ASTM D3034). Equivalent fittings from other manufactures are acceptable at the discretion of the Engineer. Written acceptance must be obtained from the Engineer prior to the equivalent materials being approved. Geometric standards cannot be varied. All connections to existing pipes shall be made with non-shear "FERNCO RC Series" or "MISSON Flex-Seal" adjustable repair couplings equipped with stainless steel bands.

Excavation, backfilling, and disposal of materials will not be paid for separately but shall be included in the cost of this item.

**Basis of Payment.** This work will be paid for at the contract unit price per each for SANITARY SEWER CLEAN OUT.

### **PAY ITEMS #84 & #85 – SANITARY SEWER REPAIR, REMOVE AND REPLACE**

**Description.** This work shall consist of repairing sanitary sewers by removing and replacing segments of sanitary services or main designated by the Engineer in the field. Multiple repairs may exist throughout multiple segments of sanitary sewers ranging from a minimum repair length of 5 feet

to the length required by the Engineer. This item shall also include the re-connection of existing services, the re-connection of new sewer pipe with existing sewer pipe, and the connection of the new sewer pipe to the existing manhole, including outside drop connection. All work shall be performed in accordance with Section 550 of the Standard Specifications and Section 31 and 40 of the Water and Sewer Specifications, with the following modifications:

All trench backfill required according to Section 208 of the Standard Specifications shall be included in the cost of this item.

Any reference made to storm sewers in Section 550 of the Standard Specifications shall also apply to sanitary sewers and services described herein.

**Materials.** Sanitary sewer shall be polyvinyl chloride (PVC) pipe with a Standard Dimension Ratio (SDR) of 26 conforming to ASTM D2241 with gasket joints conforming to ASTM D3212. If PVC pipe material per ASTM D2241 is not available, then an alternate material designation can be requested to the Engineer for approval. All supplied pipes and fittings must be from the same manufacturer. Connections to existing sewer lines shall be made using non-shear Fernco RC Series or Mission Flex-Seal adjustable repair couplings equipped with stainless steel bands. PVC tee and bends used for the drop connection shall be compatible for use with the sewer pipe.

The re-connection of existing services shall be done with a new PVC wye or tee fitting which will be fabricated to fit the main and the branch service pipe. All supplied fittings and connections must be from the same manufacturer. All connections to existing pipes shall be made with non-shear Fernco RC Series or Mission Flex–Seal adjustable repair couplings equipped with stainless steel bands.

**Flow Control.** Prior to beginning any work which would interrupt existing flows, Contractor and Engineer will determine whether temporary plugging of the sewer line may be an acceptable alternative to by-pass pumping of flows during this work. If Contractor opts to use plugging for flow control, Contractor assumes all responsibility for the consequences, and shall be solely liable for the cost of all clean-up and any other damages which may be sustained by property owners and tenants, stemming from sewer back-ups determined to be the result of, or attributable to, this work. Contractor shall monitor upstream conditions of the plugged sewer frequently, and shall take all action necessary to minimize surcharge conditions.

Where plugging is determined not to be prudent, bypass pumping shall be used for flow control. It may be necessary to divert all or a portion of the wastewater flow to a downstream manhole. The manner and method proposed to be employed by Contractor for bypass pumping (including a plan for all additional traffic control and protection which may be necessary) shall be reviewed and approved by Engineer prior to setting up the pumping operation. By-passed flows from the sanitary sewer shall not be discharged to a storm sewer or overland.

**Method of Measurement.** Trench backfill and bypass pumping will not be measured for payment but shall be considered as included in the cost of this item.

**Basis of Payment.** This work will be paid for at the contract unit price per foot for SANITARY SEWER REPAIR, REMOVE AND REPLACE, 6-INCH DIAMETER OR LESS and SANITARY SEWER REPAIR, REMOVE AND REPLACE, OVER 6-INCH DIAMETER.

**PAY ITEM #86 – SANITARY MANHOLES**

**Description.** This work consists of furnishing and installing a new sanitary manhole, including chimney seal, frame and self-sealing lid adjusted to finished grade, at the locations shown on the plans or as directed by the Engineer in accordance with the construction details provided in the plans. This work shall be in accordance with applicable portions of Section 602 of the Standard Specifications, with the following modifications:

No more than 5 feet of existing sewer main or service pipe shall be removed in order to set the new manhole structure. The ends of the removed pipes shall be made square and sound, to facilitate a good connection with proposed pipes stubbed out from the manhole. Connecting pipes shall be cut to exact length required. A neoprene rubber coupling, as manufactured by Mission Rubber Company, Fern Company, or equal, shall be used to secure each connection between existing and new sewer pipe. Couplings shall be the non-shear type, specifically sized for the materials being connected, and shall include two type C-305 stainless steel adjustable bands.

The Type 1 Frame, Closed Lid shall meet the requirements for sanitary manholes according to the Special Provision “Frames, Grates and Lids” described herein.

**Basis of Payment.** This work will be paid for at the contract unit price per each for SANITARY MANHOLES, of the diameter specified, and with the type of frame and lid specified.

**PAY ITEM #87 – GEOGRID**

**Description.** This work shall consist of furnishing and installing a geogrid on the subgrade after the undercut has been completed as shown in the plans and construction details. The geogrid shall be composed of a single layer and integrally formed with triangular apertures and high-profile ribs exhibiting significant dimensional stability through all ribs and junctions of the geogrid structure. The geogrid shall maintain its reinforcement and aggregate confinement capabilities under repeated dynamic loads while in service. The geogrid shall also be resistant to ultraviolet degradation, damage under normal construction practices and all forms of biological and chemical degradation normally encountered in road construction.

The geogrid must meet all specifications described herein and cannot be installed without prior approval from the Engineer.

**Materials.** The geogrid shall be integrally formed through punching and drawing of extruded sheets of polypropylene. The geogrid shall be oriented in three substantially equilateral directions so the resulting ribs have a high degree of molecular orientation which continues at least in part through the mass of the integral node. The resulting geogrid structure shall have apertures that are triangular in shape, and shall have ribs with depth-to-width ratios greater than 1.0. The geogrid shall have typical characteristics shown in the table below, and shall be certified in writing by the manufacturer to meet these characteristics:

Properties	Longitudinal	Diagonal	General
Rib Pitch <sup>(2)</sup> , mm (in)	60 (2.40)	60 (2.40)	
Rib shape			rectangular
Aperture shape			triangular
Junction Efficiency <sup>(3)</sup> , %			93
Isotropic Stiffness Ratio <sup>(4,9)</sup>			0.6
Overall Flexural Rigidity <sup>(5)</sup> , mg-cm			2,000,000
Radial stiffness at low strain <sup>(6,9)</sup> , kN/m @ 0.5% strain (lb/ft @ 0.5% strain)			350 (23,989)
Resistance to chemical degradation <sup>(6)</sup>			100%
Resistance to ultra-violet light and weathering <sup>(7)</sup>			70%

1. Unless indicated otherwise, values shown are minimum average roll values (MARVs) determined in accordance with ASTM D4759-02. Brief descriptions of test procedures are given in the following notes.
2. Nominal dimensions.
3. Load transfer capability determined in accordance with ASTM D6637-10 and ASTM D7737-11 and expressed as a percentage of ultimate tensile strength.
4. The ratio between the minimum and maximum observed values of radial stiffness at 0.5% strain, measured on rib and midway between rib directions.
5. Determined in accordance with ASTM D7748-12.
6. Radial stiffness is determined from tensile stiffness measured in any in-plane axis from testing in accordance with ASTM D6637-10.
7. Resistance to loss of load capacity or structural integrity when subjected to chemically aggressive environments in accordance with EPA 9090 immersion testing.
8. Resistance to loss of load capacity or structural integrity when subjected to 500 hours of ultraviolet light and aggressive weathering in accordance with ASTM D4355-05.
9. Isotropic stiffness ratio and radial stiffness values at 0.5% strain are both preliminary estimates and are subject to change.

The product, TX190L from Tensar International Corp., or approved equal, can be used to meet the material specifications described above. Alternate geogrid materials may be considered if they meet or exceed the design criteria of the project. Such materials must be pre-approved in writing by the Engineer.

**Delivery, Storage and Handling.** Prevent excessive mud, wet concrete, epoxy or other deleterious materials from coming in contact with and affixing to the geogrid. Store the geogrid at temperatures above -20 degrees F (-29 degrees C). The rolled geogrid may be laid flat or stood on end, but should not be left directly exposed to sunlight for more than 6 months or as recommended by the manufacturer. Any damage caused to geogrid by negligence of Contractor shall be replaced at Contractor's own expense.

**Installation.** The geogrid shall be installed in accordance with the specifications and installation guidelines provided by the manufacturer, or as directed by the Engineer, at the proper elevation and alignment as shown on the plans. The geogrid may be temporarily secured in place with ties, staples, pins, sand bags or backfill as directed by the Engineer. Aggregate shall be placed according to the

BDE special provision "Aggregate Subgrade Improvement". The aggregate shall be placed, spread and compacted in such a manner that minimizes the development of wrinkles in the geogrid and/or movement of the geogrid. A minimum loose aggregate thickness of 6 inches is required prior to operation of tracked vehicles over the geogrid. Turning of tracked vehicles should be kept to a minimum to prevent tracks from displacing the aggregate base material and damaging the geogrid. When underlying subgrade is trafficable with minimal rutting, rubber-tired equipment may pass directly over the geogrid reinforcement at slow speeds (less than 5 mph). Sudden braking and sharp turning movements shall be avoided.

**Method of Measurement.** Geogrid will be measured for payment in place and the area computed in square yards. No allowance will be made for overlap, splices or material cut off or wasted. Different manufacturer's overlap and splicing requirements for the intended application may vary.

**Basis of Payment.** This work will be paid for at the contract unit price per square yard for GEOGRID.

#### **PAY ITEM #88 – REMOVE DECORATIVE STONE**

**Description.** This work shall consist of the removal of existing decorative stones in order to install the proposed curb and gutter, driveway, sidewalk, or trench for underground utilities, at locations shown on the plans or as directed by the Engineer.

The Contractor shall properly dispose of the stones off-site.

**Method of Measurement.** This work will be measured for payment in units of each for decorative stones removed.

**Basis of Payment.** This work shall be paid for at the contract unit price per each for REMOVE DECORATIVE STONE.

#### **PAY ITEM #89 – WATER USAGE DEDUCTION**

**Description.** Pay items are provided as a part of this contract for the purpose of documenting the quantity of water obtained from the Village by the Contractor.

If the Contractor elects to obtain water from the Village, the Contractor shall comply with the Special Provision USE OF FIRE HYDRANTS. The quantity of water obtained from the Village by the Contractor shall be deducted from the contract as WATER USAGE DEDUCTION, and shall be credited to the contract as WATER USAGE CREDIT.

The WATER USAGE DEDUCTION pay item for this contract has been established with a unit of measurement in thousands of gallons (TGAL), a quantity of one-hundred (100.00), and a contract unit price of a deduction of eight dollars and eighty-five cents (\$8.85), for a total WATER USAGE DEDUCTION contract price of a deduction of eight-hundred eighty-five dollars and no cents (\$885.00). Bidder, in submitting a bid, accepts the quantity, contract unit price, and total contract price of the WATER USAGE DEDUCTION pay item.

**Method of Measurement.** Water usage will be measured as the actual quantity of water obtained from the Village by the Contractor, which quantity shall be rounded up to the nearest 1,000 gallons.

**Basis of Payment.** The water usage deduction will be deducted at the contract unit price per thousand gallons (TGAL) for WATER USAGE DEDUCTION. The quantity deducted as WATER USAGE DEDUCTION will be equal to the quantity paid for as WATER USAGE CREDIT.

#### **PAY ITEM #90 – WATER USAGE CREDIT**

**Description.** Pay items are provided as a part of this contract for the purpose of documenting the quantity of water obtained from the Village by the Contractor.

If the Contractor elects to obtain water from the Village, the Contractor shall comply with the Special Provision USE OF FIRE HYDRANTS. The quantity of water obtained from the Village by the Contractor shall be deducted from the contract as WATER USAGE DEDUCTION, and shall be credited to the contract as WATER USAGE CREDIT.

The WATER USAGE CREDIT pay item for this contract has been established with a unit of measurement in thousands of gallons (TGAL), a quantity of one-hundred (100.00), and a contract unit price of eight dollars and eighty-five cents (\$8.85), for a total WATER USAGE CREDIT contract price of eight-hundred eighty-five dollars and no cents (\$885.00). Bidder, in submitting a bid, accepts the quantity, contract unit price, and total contract price of the WATER USAGE CREDIT pay item.

**Method of Measurement.** Water usage will be measured as the actual quantity of water obtained from the Village by the Contractor, which quantity shall be rounded up to the nearest 1,000 gallons.

**Basis of Payment.** The water usage credit will be paid for at the contract unit price per thousand gallons (TGAL) for WATER USAGE CREDIT. The quantity paid for as WATER USAGE CREDIT will be equal to the quantity deducted as WATER USAGE DEDUCTION.

#### **PAY ITEM #91 – CONTINGENCY ALLOWANCE**

**Description.** A contingency allowance pay item is provided as a part of this contract for the purpose of facilitating the completion of unforeseen or additional work not included in the contract as awarded, and which is determined by the Engineer to be necessary and germane to the contract.

Use of the contingency allowance will be at the discretion of the Engineer. The Engineer may, at his/her discretion, use the contingency allowance for any of the following reasons:

- (a) Facilitate a temporary payment allowance to the Contractor for work completed under existing contract pay items and for which completed quantities exceed contract quantities;
- (b) Facilitate a temporary payment allowance to the Contractor for work completed beyond the scope of existing contract pay items; or
- (c) Facilitate a temporary payment allowance to the Contractor for the purchase of equipment, materials or such other requisition as Engineer determines to be necessary for the completion of the Work.

Such use of the CONTINGENCY ALLOWANCE will be further subject to approval by Owner. Owner's decision with regard to use of the CONTINGENCY ALLOWANCE will be final.

- A. Any payments made to Contractor under the CONTINGENCY ALLOWANCE will be considered temporary, and will only be retained by Contractor until such time that an authorization of contract changes can be approved and incorporated into the contract.
- B. Contractor, in accepting payments made under the CONTINGENCY ALLOWANCE, agrees to the terms of this and other applicable special provisions. Contractor agrees to relinquish any monies and any claim to monies paid under the CONTINGENCY ALLOWANCE upon approval of an authorization of contract changes and payment for any work for which payment was previously made under the CONTINGENCY ALLOWANCE. Contractor further agrees to return any monies previously paid thereunder.
- C. The CONTINGENCY ALLOWANCE pay item for this contract has been established with a unit of measurement in dollars, a quantity of 30,000, and a contract unit price of one dollar (\$1.00), for a total CONTINGENCY ALLOWANCE contract price of Thirty Thousand dollars and no cents (\$30,000.00). Bidder, in submitting a bid, accepts the quantity, unit price, and total contract price of the CONTINGENCY ALLOWANCE.

**Basis of Payment.** This work will be paid for at the contract unit price per dollar for CONTINGENCY ALLOWANCE. The total bid amount for this item will be \$30,000.00.

NOT FOR BIDDING

**APPENDIX 1**  
**INDEX FOR SUPPLEMENTAL SPECIFICATIONS AND RECURRING SPECIAL PROVISIONS**  
**CHECK SHEET FOR RECURRING SPECIAL PROVISIONS**  
**BDE SPECIAL PROVISIONS**  
**LOCAL ROADS SPECIAL PROVISIONS**  
**DUPAGE COUNTY PREVAILING WAGES**

**NOT FOR BIDDING**

INDEX  
FOR  
SUPPLEMENTAL SPECIFICATIONS  
AND RECURRING SPECIAL PROVISIONS

Adopted January 1, 2017

This index contains a listing of SUPPLEMENTAL SPECIFICATIONS, frequently used RECURRING SPECIAL PROVISIONS, and LOCAL ROADS AND STREETS RECURRING SPECIAL PROVISIONS.

ERRATA Standard Specifications for Road and Bridge Construction  
(Adopted 4-1-16) (Revised 1-1-17)

SUPPLEMENTAL SPECIFICATIONS

<u>Std. Spec. Sec.</u>		<u>Page No.</u>
106	Control of Materials .....	1
403	Bituminous Surface Treatment (Class A-1, A-2, A-3) .....	2
420	Portland Cement Concrete Pavement .....	3
502	Excavation for Structures .....	5
503	Concrete Structures .....	7
504	Precast Concrete Structures .....	10
542	Pipe Culverts .....	11
586	Sand Backfill for Vaulted Abutments .....	12
670	Engineer's Field Office and Laboratory .....	14
704	Temporary Concrete Barrier .....	15
888	Pedestrian Push-Button .....	17
1003	Fine Aggregates .....	18
1004	Coarse Aggregates .....	19
1006	Metals .....	21
1020	Portland Cement Concrete .....	22
1103	Portland Cement Concrete Equipment .....	24



The Following Recurring Special Provisions Indicated By An "X" Are Applicable To This Contract And Are Included By Reference:

Recurring Special Provisions

<u>Check Sheet #</u>		<u>Page No.</u>
1	<input type="checkbox"/> Additional State Requirements for Federal-Aid Construction Contracts	26
2	<input type="checkbox"/> Subletting of Contracts (Federal-Aid Contracts)	29
3	<input type="checkbox"/> EEO	30
4	<input type="checkbox"/> Specific EEO Responsibilities Non Federal-Aid Contracts	40
5	<input type="checkbox"/> Required Provisions - State Contracts	45
6	<input type="checkbox"/> Asbestos Bearing Pad Removal	51
7	<input type="checkbox"/> Asbestos Waterproofing Membrane and Asbestos Hot-Mix Asphalt Surface Removal	52
8	<input type="checkbox"/> Temporary Stream Crossings and In-Stream Work Pads	53
9	<input type="checkbox"/> Construction Layout Stakes Except for Bridges	54
10	<input checked="" type="checkbox"/> Construction Layout Stakes	57
11	<input type="checkbox"/> Use of Geotextile Fabric for Railroad Crossing	60
12	<input type="checkbox"/> Subsealing of Concrete Pavements	62
13	<input type="checkbox"/> Hot-Mix Asphalt Surface Correction	66
14	<input type="checkbox"/> Pavement and Shoulder Resurfacing	68
15	<input type="checkbox"/> Patching with Hot-Mix Asphalt Overlay Removal	69
16	<input type="checkbox"/> Polymer Concrete	70
17	<input type="checkbox"/> PVC Pipeliner	72
18	<input type="checkbox"/> Bicycle Racks	73
19	<input type="checkbox"/> Temporary Portable Bridge Traffic Signals	75
20	<input type="checkbox"/> Work Zone Public Information Signs	77
21	<input type="checkbox"/> Nighttime Inspection of Roadway Lighting	78
22	<input type="checkbox"/> English Substitution of Metric Bolts	79
23	<input type="checkbox"/> Calcium Chloride Accelerator for Portland Cement Concrete	80
24	<input type="checkbox"/> Quality Control of Concrete Mixtures at the Plant	81
25	<input checked="" type="checkbox"/> Quality Control/Quality Assurance of Concrete Mixtures	89
26	<input type="checkbox"/> Digital Terrain Modeling for Earthwork Calculations	105
27	<input type="checkbox"/> Reserved	107
28	<input type="checkbox"/> Preventive Maintenance - Bituminous Surface Treatment	108
29	<input type="checkbox"/> Preventive Maintenance - Cape Seal	114
30	<input type="checkbox"/> Preventive Maintenance - Micro-Surfacing	129
31	<input type="checkbox"/> Preventive Maintenance - Slurry Seal	140
32	<input type="checkbox"/> Temporary Raised Pavement Markers	149
33	<input type="checkbox"/> Restoring Bridge Approach Pavements Using High-Density Foam	150
34	<input type="checkbox"/> Portland Cement Concrete Inlay or Overlay	153

The Following Local Roads And Streets Recurring Special Provisions Indicated By An "X" Are Applicable To This Contract And Are Included By Reference:

Local Roads And Streets Recurring Special Provisions

<u>Check Sheet #</u>		<u>Page No.</u>
LRS 1	<b>Reserved</b>	158
LRS 2	<input type="checkbox"/> Furnished Excavation	159
LRS 3	<input checked="" type="checkbox"/> Work Zone Traffic Control Surveillance	160
LRS 4	<input type="checkbox"/> Flaggers in Work Zones	161
LRS 5	<input checked="" type="checkbox"/> Contract Claims	162
LRS 6	<input checked="" type="checkbox"/> Bidding Requirements and Conditions for Contract Proposals	163
LRS 7	<input type="checkbox"/> Bidding Requirements and Conditions for Material Proposals	169
LRS 8	<b>Reserved</b>	175
LRS 9	<input type="checkbox"/> Bituminous Surface Treatments	176
LRS 10	<b>Reserved</b>	177
LRS 11	<input checked="" type="checkbox"/> Employment Practices	178
LRS 12	<input checked="" type="checkbox"/> Wages of Employees on Public Works	180
LRS 13	<input checked="" type="checkbox"/> Selection of Labor	182
LRS 14	<input type="checkbox"/> Paving Brick and Concrete Paver Pavements and Sidewalks	183
LRS 15	<input checked="" type="checkbox"/> Partial Payments	186
LRS 16	<input checked="" type="checkbox"/> Protests on Local Lettings	187
LRS 17	<input checked="" type="checkbox"/> Substance Abuse Prevention Program	188
LRS 18	<input type="checkbox"/> Multigrade Cold Mix Asphalt	189

NOT FOR BID

BDE SPECIAL PROVISIONS  
For the April 28 and June 16, 2017 Lettings

The following special provisions indicated by an "x" are applicable to this contract and will be included by the Project Development and Implementation Section of the BD&E. An \* indicates a new or revised special provision for the letting.

<u>File Name</u>	<u>#</u>	<u>Special Provision Title</u>	<u>Effective</u>	<u>Revised</u>
80099	1	Accessible Pedestrian Signals (APS)	April 1, 2003	Jan. 1, 2014
* 80382	2	Adjusting Frames and Grates	April 1, 2017	
80274	3	Aggregate Subgrade Improvement	April 1, 2012	April 1, 2016
80192	4	Automated Flagger Assistance Device	Jan. 1, 2008	
80173	5	Bituminous Materials Cost Adjustments	Nov. 2, 2006	July 1, 2015
80241	6	Bridge Demolition Debris	July 1, 2009	
5026I	7	Building Removal-Case I (Non-Friable and Friable Asbestos)	Sept. 1, 1990	April 1, 2010
5048I	8	Building Removal-Case II (Non-Friable Asbestos)	Sept. 1, 1990	April 1, 2010
5049I	9	Building Removal-Case III (Friable Asbestos)	Sept. 1, 1990	April 1, 2010
5053I	10	Building Removal-Case IV (No Asbestos)	Sept. 1, 1990	April 1, 2010
80366	11	Butt Joints	July 1, 2016	
80198	12	Completion Date (via calendar days)	April 1, 2008	
80199	13	Completion Date (via calendar days) Plus Working Days	April 1, 2008	
80293	14	Concrete Box Culverts with Skews > 30 Degrees and Design Fills ≤ 5 Feet	April 1, 2012	July 1, 2016
80311	15	Concrete End Sections for Pipe Culverts	Jan. 1, 2013	April 1, 2016
80277	16	Concrete Mix Design – Department Provided	Jan. 1, 2012	April 1, 2016
80261	17	Construction Air Quality – Diesel Retrofit	June 1, 2010	Nov. 1, 2014
80029	18	Disadvantaged Business Enterprise Participation	Sept. 1, 2000	July 2, 2016
80378	19	Dowel Bar Inserter	Jan. 1, 2017	
80229	20	Fuel Cost Adjustment	April 1, 2009	July 1, 2015
80304	21	Grooving for Recessed Pavement Markings	Nov. 1, 2012	Aug. 1, 2014
80246	22	Hot-Mix Asphalt – Density Testing of Longitudinal Joints	Jan. 1, 2010	April 1, 2016
* 80347	23	Hot-Mix Asphalt – Pay for Performance Using Percent Within Limits – Jobsite Sampling	Nov. 1, 2014	April 1, 2017
* 80383	24	Hot-Mix Asphalt – Quality Control for Performance	April 1, 2017	
80376	25	Hot-Mix Asphalt – Tack Coat	Nov. 1, 2016	
80367	26	Light Poles	July 1, 2016	
80368	27	Light Tower	July 1, 2016	
80336	28	Longitudinal Joint and Crack Patching	April 1, 2014	April 1, 2016
80369	29	Mast Arm Assembly and Pole	July 1, 2016	
80045	30	Material Transfer Device	June 15, 1999	Aug. 1, 2014
80165	31	Moisture Cured Urethane Paint System	Nov. 1, 2006	Jan. 1, 2010
80349	32	Pavement Marking Blackout Tape	Nov. 1, 2014	April 1, 2016
80371	33	Pavement Marking Removal	July 1, 2016	
* 80377	34	Portable Changeable Message Signs	Nov. 1, 2016	April 1, 2017
80359	35	Portland Cement Concrete Bridge Deck Curing	April 1, 2015	Jan. 1, 2017
80338	36	Portland Cement Concrete Partial Depth Hot-Mix Asphalt Patching	April 1, 2014	April 1, 2016
80300	37	Preformed Plastic Pavement Marking Type D - Inlaid	April 1, 2012	April 1, 2016
80328	38	Progress Payments	Nov. 2, 2013	
3426I	39	Railroad Protective Liability Insurance	Dec. 1, 1986	Jan. 1, 2006
80157	40	Railroad Protective Liability Insurance (5 and 10)	Jan. 1, 2006	
80306	41	Reclaimed Asphalt Pavement (RAP) and Reclaimed Asphalt Shingles (RAS)	Nov. 1, 2012	April 1, 2016
80340	42	Speed Display Trailer	April 2, 2014	Jan. 1, 2017
80127	43	Steel Cost Adjustment	April 2, 2004	July 1, 2015

<u>File Name</u>	<u>#</u>	<u>Special Provision Title</u>	<u>Effective</u>	<u>Revised</u>
80379	44	Steel Plate Beam Guardrail	Jan. 1, 2017	
80317	45	Surface Testing of Hot-Mix Asphalt Overlays	Jan. 1, 2013	April 1, 2016
* 80298	46	Temporary Pavement Marking (NOTE: This special provision was previously named "Pavement Marking Tape Type IV".)	April 1, 2012	April 1, 2017
20338	47	Training Special Provisions	Oct. 15, 1975	
80318	48	Traversable Pipe Grate	Jan. 1, 2013	April 1, 2014
80381	49	Traffic Barrier Terminal, Type 1 Special	Jan. 1, 2017	
80380	50	Tubular Markers	Jan. 1, 2017	
80288	51	Warm Mix Asphalt	Jan. 1, 2012	April 1, 2016
80302	52	Weekly DBE Trucking Reports	June 2, 2012	April 2, 2015
80289	53	Wet Reflective Thermoplastic Pavement Marking	Jan. 1, 2012	
80071	54	Working Days	Jan. 1, 2002	

The following special provisions are in the 2017 Supplemental Specifications and Recurring Special Provisions.

<u>File Name</u>	<u>Special Provision Title</u>	<u>New Location</u>	<u>Effective</u>	<u>Revised</u>
80360	Coarse Aggregate Quality	Article 1004.01	July 1, 2015	
80363	Engineer's Field Office	Article 670.07	April 1, 2016	
80358	Equal Employment Opportunity	Recurring CS #1 and #5	April 1, 2015	
80364	Errata for the 2016 Standard Specifications	Supplemental	April 1, 2016	
80342	Mechanical Side Tie Bar Inserter	Articles 420.03, 420.05, and 1103.19	Aug. 1, 2014	April 1, 2016
80370	Mechanical Splicers	Article 1006.10	July 1, 2016	
80361	Overhead Sign Structures Certification of Metal Fabricator	Article 106.08	Nov. 1, 2015	April 1, 2016
80365	Pedestrian Push-Button	Article 888.03	April 1, 2016	
80353	Portland Cement Concrete Inlay or Overlay	Recurring CS #34	Jan. 1, 2015	April 1, 2016
80372	Preventive Maintenance – Bituminous Surface Treatment (A-1)	Recurring CS #28	Jan. 1, 2009	July 1, 2016
80373	Preventive Maintenance – Cape Seal	Recurring CS #29	Jan. 1, 2009	July 1, 2016
80374	Preventive Maintenance – Micro-Surfacing	Recurring CS #30	Jan. 1, 2009	July 1, 2016
80375	Preventive Maintenance – Slurry Seal	Recurring CS #31	Jan. 1, 2009	July 1, 2016
80362	Steel Slag in Trench Backfill	Articles 1003.01 and 1003.04	Jan. 1, 2016	
80355	Temporary Concrete Barrier	Articles 704.02, 704.04, 704.05, and 704.06	Jan. 1, 2015	July 1, 2015

The following special provisions require additional information from the designer. The additional information needs to be included in a separate document attached to this check sheet. The Project Development and Implementation section will then include the information in the applicable special provision. The Special Provisions are:

- Bridge Demolition Debris
- Building Removal - Case I
- Building Removal – Case II
- Building Removal - Case III
- Building Removal-Case IV
- Completion Date
- Completion Date Plus Working Days
- DBE Participation
- Material Transfer Device
- Railroad Protective Liability Insurance
- Training Special Provisions
- Working Days

## CONSTRUCTION AIR QUALITY – DIESEL RETROFIT (BDE)

Effective: June 1, 2010

Revised: November 1, 2014

The reduction of emissions of particulate matter (PM) for off-road equipment shall be accomplished by installing retrofit emission control devices. The term “equipment” refers to diesel fuel powered devices rated at 50 hp and above, to be used on the jobsite in excess of seven calendar days over the course of the construction period on the jobsite (including rental equipment).

Contractor and subcontractor diesel powered off-road equipment assigned to the contract shall be retrofitted using the phased in approach shown below. Equipment that is of a model year older than the year given for that equipment’s respective horsepower range shall be retrofitted:

Effective Dates	Horsepower Range	Model Year
June 1, 2010 <sup>1/</sup>	600-749	2002
	750 and up	2006
June 1, 2011 <sup>2/</sup>	100-299	2003
	300-599	2001
	600-749	2002
	750 and up	2006
June 1, 2012 <sup>2/</sup>	50-99	2004
	100-299	2003
	300-599	2001
	600-749	2002
	750 and up	2006

1/ Effective dates apply to Contractor diesel powered off-road equipment assigned to the contract.

2/ Effective dates apply to Contractor and subcontractor diesel powered off-road equipment assigned to the contract.

The retrofit emission control devices shall achieve a minimum PM emission reduction of 50 percent and shall be:

- a) Included on the U.S. Environmental Protection Agency (USEPA) *Verified Retrofit Technology List* (<http://www.epa.gov/cleandiesel/verification/verif-list.htm>), or verified by the California Air Resources Board (CARB) (<http://www.arb.ca.gov/diesel/verdev/vt/cvt.htm>); or
- b) Retrofitted with a non-verified diesel retrofit emission control device if verified retrofit emission control devices are not available for equipment proposed to be used on the project, and if the Contractor has obtained a performance certification from the retrofit

device manufacturer that the emission control device provides a minimum PM emission reduction of 50 percent.

Note: Large cranes (Crawler mounted cranes) which are responsible for critical lift operations are exempt from installing retrofit emission control devices if such devices adversely affect equipment operation.

Diesel powered off-road equipment with engine ratings of 50 hp and above, which are unable to be retrofitted with verified emission control devices or if performance certifications are not available which will achieve a minimum 50 percent PM reduction, may be granted a waiver by the Department if documentation is provided showing good faith efforts were made by the Contractor to retrofit the equipment.

Construction shall not proceed until the Contractor submits a certified list of the diesel powered off-road equipment that will be used, and as necessary, retrofitted with emission control devices. The list(s) shall include (1) the equipment number, type, make, Contractor/rental company name; and (2) the emission control devices make, model, USEPA or CARB verification number, or performance certification from the retrofit device manufacturer. Equipment reported as fitted with emissions control devices shall be made available to the Engineer for visual inspection of the device installation, prior to being used on the jobsite.

The Contractor shall submit an updated list of retrofitted off-road construction equipment as retrofitted equipment changes or comes on to the jobsite. The addition or deletion of any diesel powered equipment shall be included on the updated list.

If any diesel powered off-road equipment is found to be in non-compliance with any portion of this special provision, the Engineer will issue the Contractor a diesel retrofit deficiency deduction.

Any costs associated with retrofitting any diesel powered off-road equipment with emission control devices shall be considered as included in the contract unit prices bid for the various items of work involved and no additional compensation will be allowed. The Contractor's compliance with this notice and any associated regulations shall not be grounds for a claim.

### **Diesel Retrofit Deficiency Deduction**

When the Engineer determines that a diesel retrofit deficiency exists, a daily monetary deduction will be imposed for each calendar day or fraction thereof the deficiency continues to exist. The calendar day(s) will begin when the time period for correction is exceeded and end with the Engineer's written acceptance of the correction. The daily monetary deduction will be \$1,000.00 for each deficiency identified.

The deficiency will be based on lack of diesel retrofit emissions control.

If a Contractor accumulates three diesel retrofit deficiency deductions for the same piece of equipment in a contract period, the Contractor will be shutdown until the deficiency is corrected.

Such a shutdown will not be grounds for any extension of the contract time, waiver of penalties, or be grounds for any claim.

80261

**NOT FOR BID**

## HOT-MIX ASPHALT - DENSITY TESTING OF LONGITUDINAL JOINTS (BDE)

Effective: January 1, 2010

Revised: April 1, 2016

Description. This work shall consist of testing the density of longitudinal joints as part of the quality control/quality assurance (QC/QA) of hot-mix asphalt (HMA). Work shall be according to Section 1030 of the Standard Specifications except as follows.

Quality Control/Quality Assurance (QC/QA). Delete the second and third sentence of the third paragraph of Article 1030.05(d)(3) of the Standard Specifications.

Add the following paragraphs to the end of Article 1030.05(d)(3) of the Standard Specifications:

“Longitudinal joint density testing shall be performed at each random density test location. Longitudinal joint testing shall be located at a distance equal to the lift thickness or a minimum of 4 in. (100 mm), from each pavement edge. (i.e. for a 5 in. (125 mm) lift the near edge of the density gauge or core barrel shall be within 5 in. (125 mm) from the edge of pavement.) Longitudinal joint density testing shall be performed using either a correlated nuclear gauge or cores.

- a. Confined Edge. Each confined edge density shall be represented by a one-minute nuclear density reading or a core density and shall be included in the average of density readings or core densities taken across the mat which represents the Individual Test.
- b. Unconfined Edge. Each unconfined edge joint density shall be represented by an average of three one-minute density readings or a single core density at the given density test location and shall meet the density requirements specified herein. The three one-minute readings shall be spaced 10 ft (3 m) apart longitudinally along the unconfined pavement edge and centered at the random density test location.”

Revise the Density Control Limits table in Article 1030.05(d)(4) of the Standard Specifications to read:

“Mixture Composition	Parameter	Individual Test (includes confined edges)	Unconfined Edge Joint Density Minimum
IL-4.75	Ndesign = 50	93.0 – 97.4% <sup>1/</sup>	91.0%
IL-9.5	Ndesign = 90	92.0 – 96.0%	90.0%
IL-9.5, IL-9.5L	Ndesign < 90	92.5 – 97.4%	90.0%
IL-19.0	Ndesign = 90	93.0 – 96.0%	90.0%
IL-19.0, IL-19.0L	Ndesign < 90	93.0 <sup>2/</sup> – 97.4%	90.0%
SMA	Ndesign = 50 & 80	93.5 – 97.4%	91.0%”

## PROGRESS PAYMENTS (BDE)

Effective: November 2, 2013

Revise Article 109.07(a) of the Standard Specifications to read:

“(a) Progress Payments. At least once each month, the Engineer will make a written estimate of the quantity of work performed in accordance with the contract, and the value thereof at the contract unit prices. The amount of the estimate approved as due for payment will be vouchered by the Department and presented to the State Comptroller for payment. No amount less than \$1000.00 will be approved for payment other than the final payment.

Progress payments may be reduced by liens filed pursuant to Section 23(c) of the Mechanics' Lien Act, 770 ILCS 60/23(c).

If a Contractor or subcontractor has defaulted on a loan issued under the Department's Disadvantaged Business Revolving Loan Program (20 ILCS 2705/2705-610), progress payments may be reduced pursuant to the terms of that loan agreement. In such cases, the amount of the estimate related to the work performed by the Contractor or subcontractor, in default of the loan agreement, will be offset, in whole or in part, and vouchered by the Department to the Working Capital Revolving Fund or designated escrow account. Payment for the work shall be considered as issued and received by the Contractor or subcontractor on the date of the offset voucher. Further, the amount of the offset voucher shall be a credit against the Department's obligation to pay the Contractor, the Contractor's obligation to pay the subcontractor, and the Contractor's or subcontractor's total loan indebtedness to the Department. The offset shall continue until such time as the entire loan indebtedness is satisfied. The Department will notify the Contractor and Fund Control Agent in a timely manner of such offset. The Contractor or subcontractor shall not be entitled to additional payment in consideration of the offset.

The failure to perform any requirement, obligation, or term of the contract by the Contractor shall be reason for withholding any progress payments until the Department determines that compliance has been achieved.”

80328

## WARM MIX ASPHALT (BDE)

Effective: January 1, 2012

Revised: April 1, 2016

Description. This work shall consist of designing, producing and constructing Warm Mix Asphalt (WMA) in lieu of Hot Mix Asphalt (HMA) at the Contractor's option. Work shall be according to Sections 406, 407, 408, 1030, and 1102 of the Standard Specifications, except as modified herein. In addition, any references to HMA in the Standard Specifications, or the special provisions shall be construed to include WMA.

WMA is an asphalt mixture which can be produced at temperatures lower than allowed for HMA utilizing approved WMA technologies. WMA technologies are defined as the use of additives or processes which allow a reduction in the temperatures at which HMA mixes are produced and placed. WMA is produced by the use of additives, a water foaming process, or combination of both. Additives include minerals, chemicals or organics incorporated into the asphalt binder stream in a dedicated delivery system. The process of foaming injects water into the asphalt binder stream, just prior to incorporation of the asphalt binder with the aggregate.

Approved WMA technologies may also be used in HMA provided all the requirements specified herein, with the exception of temperature, are met. However, asphalt mixtures produced at temperatures in excess of 275 °F (135 °C) will not be considered WMA when determining the grade reduction of the virgin asphalt binder grade.

### Equipment.

Revise the first paragraph of Article 1102.01 of the Standard Specifications to read:

**"1102.01 Hot-Mix Asphalt Plant.** The hot-mix asphalt (HMA) plant shall be the batch-type, continuous-type, or dryer drum plant. The plants shall be evaluated for prequalification rating and approval to produce HMA according to the current Bureau of Materials and Physical Research Policy Memorandum, "Approval of Hot-Mix Asphalt Plants and Equipment". Once approved, the Contractor shall notify the Bureau of Materials and Physical Research to obtain approval of all plant modifications. The plants shall not be used to produce mixtures concurrently for more than one project or for private work unless permission is granted in writing by the Engineer. The plant units shall be so designed, coordinated and operated that they will function properly and produce HMA having uniform temperatures and compositions within the tolerances specified. The plant units shall meet the following requirements."

Add the following to Article 1102.01(a) of the Standard Specifications.

"(11) Equipment for Warm Mix Technologies.

- a. Foaming. Metering equipment for foamed asphalt shall have an accuracy of  $\pm 2$  percent of the actual water metered. The foaming control system shall be electronically interfaced with the asphalt binder meter.

- b. Additives. Additives shall be introduced into the plant according to the supplier's recommendations and shall be approved by the Engineer. The system for introducing the WMA additive shall be interlocked with the aggregate feed or weigh system to maintain correct proportions for all rates of production and batch sizes."

Mix Design Verification.

Add the following to Article 1030.04 of the Standard Specifications.

"(e) Warm Mix Technologies.

- (1) Foaming. WMA mix design verification will not be required when foaming technology is used alone (without WMA additives). However, the foaming technology shall only be used on HMA designs previously approved by the Department.
- (2) Additives. WMA mix designs utilizing additives shall be submitted to the Engineer for mix design verification."

Construction Requirements.

Revise the second paragraph of Article 406.06(b)(1) of the Standard Specifications to read:

"The HMA shall be delivered at a temperature of 250 to 350 °F (120 to 175 °C). WMA shall be delivered at a minimum temperature of 215 °F (102 °C)."

Basis of Payment.

This work will be paid at the contract unit price bid for the HMA pay items involved. Anti-strip will not be paid for separately, but shall be considered as included in the cost of the work.

80288

State of Illinois  
Department of Transportation  
Bureau of Local Roads and Streets

SPECIAL PROVISION  
FOR  
INSURANCE

Effective: February 1, 2007  
Revised: August 1, 2007

All references to Sections or Articles in this specification shall be construed to mean specific Section or Article of the Standard Specifications for Road and Bridge Construction, adopted by the Department of Transportation.

The Contractor shall name the following entities as additional insured under the Contractor's general liability insurance policy in accordance with Article 107.27:

---

---

---

---

---

---

---

---

The entities listed above and their officers, employees, and agents shall be indemnified and held harmless in accordance with Article 107.26.

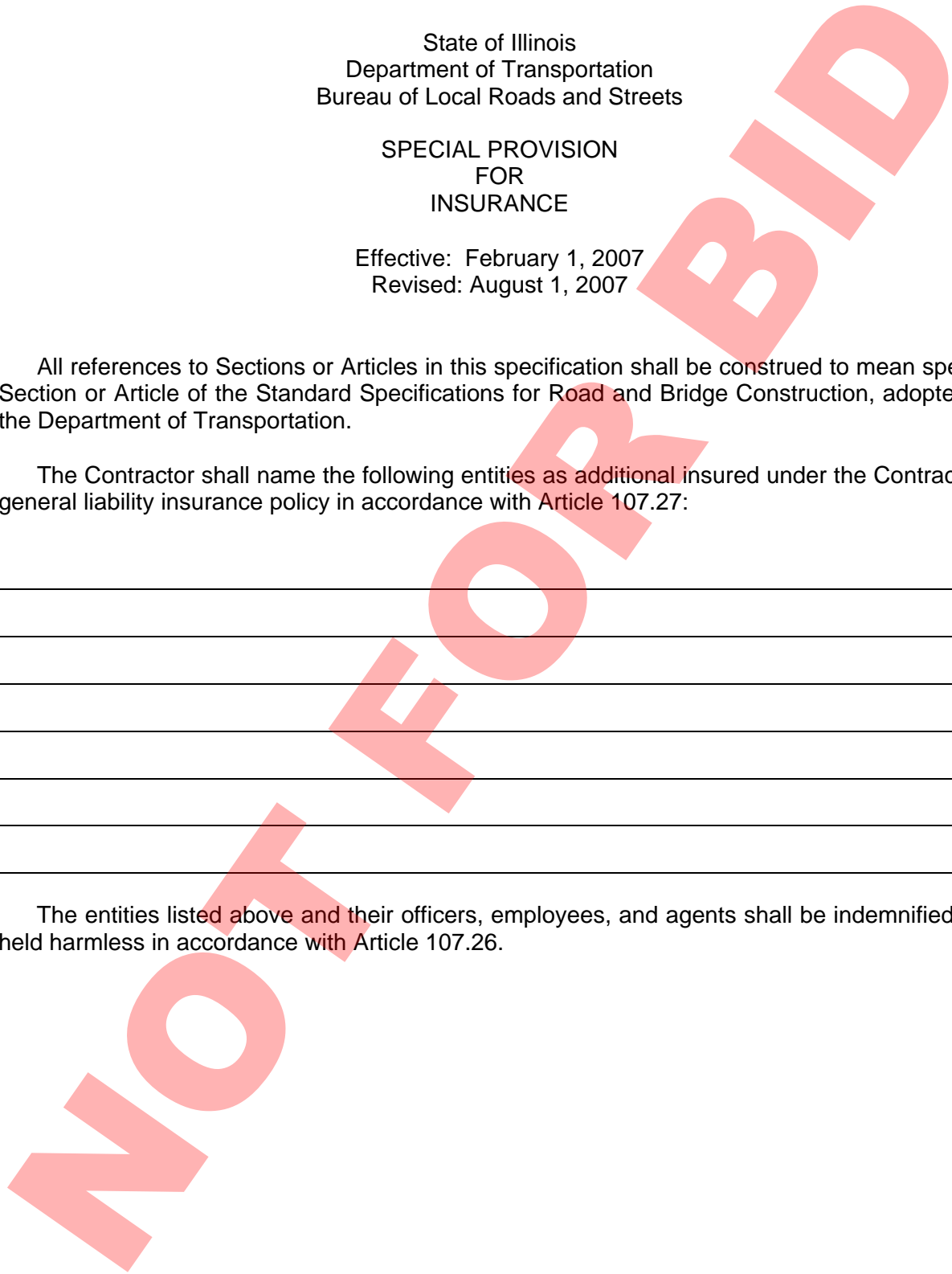

Exhibit A

Illinois Department of Labor

Division of Conciliation and Mediation

DuPage County Prevailing Wage for July, 2015

**NOT FOR BID**



TILE MASON	BLD	43.840	47.840	1.5	1.5	2.0	10.55	11.40	0.000	0.990
TRAFFIC SAFETY WRKR	HWY	32.750	34.350	1.5	1.5	2.0	6.550	6.450	0.000	0.500
TRUCK DRIVER	ALL 1	35.920	36.120	1.5	1.5	2.0	8.280	8.760	0.000	0.150
TRUCK DRIVER	ALL 2	32.700	33.100	1.5	1.5	2.0	6.500	4.350	0.000	0.150
TRUCK DRIVER	ALL 3	32.900	33.100	1.5	1.5	2.0	6.500	4.350	0.000	0.150
TRUCK DRIVER	ALL 4	33.100	33.100	1.5	1.5	2.0	6.500	4.350	0.000	0.150
TUCKPOINTER	BLD	42.620	43.620	1.5	1.5	2.0	10.05	13.34	0.000	0.670

**Legend:** RG (Region)  
 TYP (Trade Type - All, Highway, Building, Floating, Oil & Chip, Rivers)  
 C (Class)  
 Base (Base Wage Rate)  
 FRMAN (Foreman Rate)  
 M-F>8 (OT required for any hour greater than 8 worked each day, Mon through Fri.)  
 OSA (Overtime (OT) is required for every hour worked on Saturday)  
 OSH (Overtime is required for every hour worked on Sunday and Holidays)  
 H/W (Health & Welfare Insurance)  
 Pensn (Pension)  
 Vac (Vacation)  
 Trng (Training)

## Explanations

DUPAGE COUNTY

IRON WORKERS AND FENCE ERECTOR (WEST) - West of Route 53.

The following list is considered as those days for which holiday rates of wages for work performed apply: New Years Day, Memorial Day, Fourth of July, Labor Day, Thanksgiving Day, Christmas Day and Veterans Day in some classifications/counties. Generally, any of these holidays which fall on a Sunday is celebrated on the following Monday. This then makes work performed on that Monday payable at the appropriate overtime rate for holiday pay. Common practice in a given local may alter certain days of celebration. If in doubt, please check with IDOL.

### EXPLANATION OF CLASSES

ASBESTOS - GENERAL - removal of asbestos material/mold and hazardous materials from any place in a building, including mechanical systems where those mechanical systems are to be removed. This includes the removal of asbestos materials/mold and hazardous materials from ductwork or pipes in a building when the building is to be demolished at the time or at some close future date.

ASBESTOS - MECHANICAL - removal of asbestos material from mechanical systems, such as pipes, ducts, and boilers, where the mechanical systems are to remain.

TRAFFIC SAFETY - work associated with barricades, horses and drums used to reduce lane usage on highway work, the installation and removal of temporary lane markings, and the installation and removal of temporary road signs.

### CERAMIC TILE FINISHER

The grouting, cleaning, and polishing of all classes of tile, whether for interior or exterior purposes, all burned, glazed or unglazed products; all composition materials, granite tiles, warning detectable tiles, cement tiles, epoxy composite materials, pavers, glass, mosaics, fiberglass, and all substitute materials, for tile made in tile-like units; all mixtures in tile like form of cement, metals, and other materials that are for and intended for use as a finished floor surface, stair treads, promenade roofs, walks, walls, ceilings, swimming pools, and all other places where tile is to form a finished interior or exterior. The mixing of all setting mortars including but not limited to thin-set mortars, epoxies, wall mud, and any other sand and cement mixtures or adhesives when used in the preparation, installation, repair, or maintenance of tile and/or similar materials. The handling and unloading of all sand, cement, lime, tile, fixtures, equipment, adhesives, or any other materials to be used in the preparation, installation, repair, or maintenance of tile and/or similar materials. Ceramic Tile Finishers shall fill all joints and voids regardless of method on all tile work, particularly and especially after installation of said tile work. Application of any and all protective coverings to all types of tile installations including, but not be limited to, all soap compounds, paper products, tapes, and all polyethylene coverings, plywood, masonite, cardboard, and any new type of products that may be used to protect tile installations, Blastrac equipment, and all floor scarifying equipment used in preparing floors to receive tile. The clean up and removal of all waste and materials. All demolition of existing tile floors and walls to be re-tiled.

## COMMUNICATIONS TECHNICIAN

Low voltage installation, maintenance and removal of telecommunication facilities (voice, sound, data and video) including telephone and data inside wire, interconnect, terminal equipment, central offices, PABX, fiber optic cable and equipment, micro waves, V-SAT, bypass, CATV, WAN (wide area networks), LAN (local area networks), and ISDN (integrated system digital network), pulling of wire in raceways, but not the installation of raceways.

## MARBLE FINISHER

Loading and unloading trucks, distribution of all materials (all stone, sand, etc.), stocking of floors with material, performing all rigging for heavy work, the handling of all material that may be needed for the installation of such materials, building of scaffolding, polishing if needed, patching, waxing of material if damaged, pointing up, caulking, grouting and cleaning of marble, holding water on diamond or Carborundum blade or saw for setters cutting, use of tub saw or any other saw needed for preparation of material, drilling of holes for wires that anchor material set by setters, mixing up of molding plaster for installation of material, mixing up thin set for the installation of material, mixing up of sand to cement for the installation of material and such other work as may be required in helping a Marble Setter in the handling of all material in the erection or installation of interior marble, slate, travertine, art marble, serpentine, alberene stone, blue stone, granite and other stones (meaning as to stone any foreign or domestic materials as are specified and used in building interiors and exteriors and customarily known as stone in the trade), carrara, sanionyx, vitrolite and similar opaque glass and the laying of all marble tile, terrazzo tile, slate tile and precast tile, steps, risers treads, base, or any other materials that may be used as substitutes for any of the aforementioned materials and which are used on interior and exterior which are installed in a similar manner.

MATERIAL TESTER I: Hand coring and drilling for testing of materials; field inspection of uncured concrete and asphalt.

MATERIAL TESTER II: Field inspection of welds, structural steel, fireproofing, masonry, soil, facade, reinforcing steel, formwork, cured concrete, and concrete and asphalt batch plants; adjusting proportions of bituminous mixtures.

## OPERATING ENGINEER - BUILDING

Class 1. Asphalt Plant; Asphalt Spreader; Autograde; Backhoes with Caisson Attachment; Batch Plant; Benoto (requires Two Engineers); Boiler and Throttle Valve; Caisson Rigs; Central Redi-Mix Plant; Combination Back Hoe Front End-loader Machine; Compressor and Throttle Valve; Concrete Breaker (Truck Mounted); Concrete Conveyor; Concrete Conveyor (Truck Mounted); Concrete Paver Over 27E cu. ft; Concrete Paver 27E cu. ft. and Under; Concrete Placer; Concrete Placing Boom; Concrete Pump (Truck Mounted); Concrete Tower; Cranes, All; Cranes, Hammerhead; Cranes, (GCI and similar Type); Creter Crane; Spider Crane; Crusher, Stone, etc.; Derricks, All; Derricks, Traveling; Formless Curb and Gutter Machine; Grader, Elevating; Grouting Machines; Heavy Duty Self-Propelled Transporter or Prime Mover; Highlift Shovels or Front Endloader 2-1/4 yd. and over; Hoists, Elevators, outside type rack and pinion and similar machines; Hoists, One, Two and Three Drum; Hoists, Two Tugger One Floor; Hydraulic Backhoes; Hydraulic Boom Trucks; Hydro Vac (and similar equipment); Locomotives, All; Motor Patrol; Lubrication Technician; Manipulators; Pile Drivers and Skid Rig; Post Hole Digger; Pre-Stress Machine; Pump Cretes Dual Ram; Pump Cretes; Squeeze Cretes-Screw Type Pumps; Gypsum Bulker and Pump; Raised and Blind Hole Drill; Roto Mill Grinder; Scoops - Tractor Drawn; Slip-Form Paver; Straddle Buggies; Operation of Tie Back Machine; Tournapull; Tractor with Boom and Side Boom; Trenching Machines.

Class 2. Boilers; Broom, All Power Propelled; Bulldozers; Concrete Mixer (Two Bag and Over); Conveyor, Portable; Forklift Trucks; Highlift Shovels or Front Endloaders under 2-1/4 yd.; Hoists, Automatic; Hoists, Inside Elevators; Hoists, Sewer Dragging Machine; Hoists, Tugger Single Drum; Laser Screed; Rock Drill (Self-Propelled); Rock Drill (Truck Mounted); Rollers, All; Steam Generators; Tractors, All; Tractor Drawn Vibratory Roller; Winch Trucks with "A" Frame.

Class 3. Air Compressor; Combination Small Equipment Operator; Generators; Heaters, Mechanical; Hoists, Inside Elevators (remodeling or renovation work); Hydraulic Power Units (Pile Driving, Extracting, and Drilling); Pumps, over 3" (1 to 3 not to exceed a total of 300 ft.); Low Boys; Pumps, Well Points; Welding Machines (2 through 5); Winches, 4 Small Electric Drill Winches.

Class 4. Bobcats and/or other Skid Steer Loaders; Oilers; and Brick Forklift.

Class 5. Assistant Craft Foreman.

Class 6. Gradall.

Class 7. Mechanics; Welders.

#### OPERATING ENGINEERS - HIGHWAY CONSTRUCTION

Class 1. Asphalt Plant; Asphalt Heater and Planer Combination; Asphalt Heater Scarfire; Asphalt Spreader; Autograder/GOMACO or other similar type machines; ABG Paver; Backhoes with Caisson Attachment; Ballast Regulator; Belt Loader; Caisson Rigs; Car Dumper; Central Redi-Mix Plant; Combination Backhoe Front Endloader Machine, (1 cu. yd. Backhoe Bucket or over or with attachments); Concrete Breaker (Truck Mounted); Concrete Conveyor; Concrete Paver over 27E cu. ft.; Concrete Placer; Concrete Tube Float; Cranes, all attachments; Cranes, Tower Cranes of all types: Creter Crane; Spider Crane; Crusher, Stone, etc.; Derricks, All; Derrick Boats; Derricks, Traveling; Dredges; Elevators, Outside type Rack & Pinion and Similar Machines; Formless Curb and Gutter Machine; Grader, Elevating; Grader, Motor Grader, Motor Patrol, Auto Patrol, Form Grader, Pull Grader, Subgrader; Guard Rail Post Driver Truck Mounted; Hoists, One, Two and Three Drum; Heavy Duty Self-Propelled Transporter or Prime Mover; Hydraulic Backhoes; Backhoes with shear attachments up to 40' of boom reach; Lubrication Technician; Manipulators; Mucking Machine; Pile Drivers and Skid Rig; Pre-Stress Machine; Pump Cretes Dual Ram; Rock Drill - Crawler or Skid Rig; Rock Drill - Truck Mounted; Rock/Track Tamper; Roto Mill Grinder; Slip-Form Paver; Snow Melters; Soil Test Drill Rig (Truck Mounted); Straddle Buggies; Hydraulic Telescoping Form (Tunnel); Operation of Tieback Machine; Tractor Drawn Belt Loader; Tractor Drawn Belt Loader (with attached pusher - two engineers); Tractor with Boom; Tractaire with Attachments; Traffic Barrier Transfer Machine; Trenching; Truck Mounted Concrete Pump with Boom; Raised or Blind Hole Drills (Tunnel Shaft); Underground Boring and/or Mining Machines 5 ft. in diameter and over tunnel, etc; Underground Boring and/or Mining Machines under 5 ft. in diameter; Wheel Excavator; Widener (APSCO).

Class 2. Batch Plant; Bituminous Mixer; Boiler and Throttle Valve; Bulldozers; Car Loader Trailing Conveyors; Combination Backhoe Front Endloader Machine (Less than 1 cu. yd. Backhoe Bucket or over or with attachments); Compressor and Throttle Valve; Compressor, Common Receiver (3); Concrete Breaker or Hydro Hammer; Concrete Grinding Machine; Concrete Mixer or Paver 7S Series to and including 27 cu. ft.; Concrete Spreader; Concrete Curing Machine, Burlap Machine, Belting Machine and Sealing Machine; Concrete Wheel Saw; Conveyor Muck Cars (Haglund or Similar Type); Drills, All; Finishing Machine - Concrete; Highlift Shovels or Front Endloader; Hoist - Sewer Dragging Machine; Hydraulic Boom Trucks (All Attachments); Hydro-Blaster; Hydro Excavating (excluding hose work); Laser Screed; All Locomotives, Dinky; Off-Road Hauling Units (including articulating) Non Self-Loading Ejection Dump; Pump Cretes: Squeeze Cretes - Screw Type Pumps, Gypsum Bulker and Pump; Roller, Asphalt; Rotary Snow Plows; Rototiller, Seaman, etc., self-propelled; Self-Propelled Compactor; Spreader - Chip - Stone, etc.; Scraper - Single/Twin Engine/Push and Pull; Scraper - Prime Mover in Tandem (Regardless of Size); Tractors pulling attachments, Sheeps Foot, Disc, Compactor, etc.; Tug Boats.

Class 3. Boilers; Brooms, All Power Propelled; Cement Supply Tender; Compressor, Common Receiver (2); Concrete Mixer (Two Bag and Over); Conveyor, Portable; Farm-Type Tractors Used for Mowing, Seeding, etc.; Forklift Trucks; Grouting Machine; Hoists, Automatic; Hoists, All Elevators; Hoists, Tugger Single Drum; Jeep Diggers; Low Boys; Pipe Jacking Machines; Post-Hole Digger; Power Saw, Concrete Power Driven; Pug Mills; Rollers, other than Asphalt; Seed and Straw Blower; Steam Generators; Stump Machine; Winch Trucks with "A" Frame; Work Boats; Tamper-Form-Motor Driven.

Class 4. Air Compressor; Combination - Small Equipment Operator; Directional Boring Machine; Generators; Heaters, Mechanical; Hydraulic Power Unit (Pile Driving, Extracting, or Drilling); Light Plants, All (1 through 5); Pumps, over 3" (1 to 3 not to exceed a total of 300 ft.); Pumps, Well Points; Vacuum Trucks (excluding hose work); Welding Machines (2 through 5); Winches, 4 Small Electric Drill Winches.

Class 5. SkidSteer Loader (all); Brick Forklifts; Oilers.

Class 6. Field Mechanics and Field Welders

Class 7. Dowell Machine with Air Compressor; Gradall and machines of like nature.

#### OPERATING ENGINEER - FLOATING

Diver. Diver Wet Tender, Diver Tender, ROV Pilot, ROV Tender

SURVEY WORKER - Operated survey equipment including data collectors, G.P.S. and robotic instruments, as well as conventional levels and transits.

#### TRUCK DRIVER - BUILDING, HEAVY AND HIGHWAY CONSTRUCTION

Class 1. Two or three Axle Trucks. A-frame Truck when used for transportation purposes; Air Compressors and Welding Machines, including those pulled by cars, pick-up trucks and tractors; Ambulances; Batch Gate Lockers; Batch Hopperman; Car and Truck Washers; Carry-alls; Fork Lifts and Hoisters; Helpers; Mechanics Helpers and Greasers; Oil Distributors 2-man operation; Pavement Breakers; Pole Trailer, up to 40 feet; Power Mower Tractors; Self-propelled Chip Spreader; Skipman; Slurry Trucks, 2-man operation; Slurry Truck Conveyor Operation, 2 or 3 man; Teamsters; Unskilled Dumpman; and Truck Drivers hauling warning lights, barricades, and portable toilets on the job site.

Class 2. Four axle trucks; Dump Crets and Adgetors under 7 yards; Dumpsters, Track Trucks, Euclids, Hug Bottom Dump Turnapulls or Turntrailers when pulling other than self-loading equipment or similar equipment under 16 cubic yards; Mixer Trucks under 7 yards; Ready-mix Plant Hopper Operator, and Winch Trucks, 2 Axles.

Class 3. Five axle trucks; Dump Crets and Adgetors 7 yards and over; Dumpsters, Track Trucks, Euclids, Hug Bottom Dump Turntrailers or turnapulls when pulling other than self-loading equipment or similar equipment over 16 cubic yards; Explosives and/or Fission Material Trucks; Mixer Trucks 7 yards or over; Mobile Cranes while in transit; Oil Distributors, 1-man operation; Pole Trailer, over 40 feet; Pole and Expandable Trailers hauling material over 50 feet long; Slurry trucks, 1-man operation; Winch trucks, 3 axles or more; Mechanic--Truck Welder and Truck Painter.

Class 4. Six axle trucks; Dual-purpose vehicles, such as mounted crane trucks with hoist and accessories; Foreman; Master Mechanic; Self-loading equipment like P.B. and trucks with scoops on the front.

#### TERRAZZO FINISHER

The handling of sand, cement, marble chips, and all other materials that may be used by the Mosaic Terrazzo Mechanic, and the mixing, grinding, grouting, cleaning and sealing of all Marble, Mosaic, and Terrazzo work, floors, base, stairs, and wainscoting by hand or machine, and in addition, assisting and aiding Marble, Masonic, and Terrazzo Mechanics.

#### Other Classifications of Work:

For definitions of classifications not otherwise set out, the Department generally has on file such definitions which are available. If a task to be performed is not subject to one of the classifications of pay set out, the Department will upon being contacted state which neighboring county has such a classification and provide such rate, such rate being deemed to exist by reference in this document. If no neighboring county rate applies to the task, the Department shall undertake a special determination, such special determination being then deemed to have existed under this determination. If a project requires these, or any classification not listed, please contact IDOL at 217-782-1710 for wage rates or clarifications.

#### LANDSCAPING

Landscaping work falls under the existing classifications for laborer, operating engineer and truck driver. The work performed by landscape plantsman and landscape laborer is covered by the existing classification of laborer. The work performed by landscape operators (regardless of equipment used or its size) is covered by the classifications of operating engineer. The work performed by landscape truck drivers (regardless of size of truck driven) is covered by the classifications of truck driver.

#### MATERIAL TESTER & MATERIAL TESTER/INSPECTOR I AND II

Notwithstanding the difference in the classification title, the classification entitled "Material Tester I" involves the same job duties as the classification entitled "Material Tester/Inspector I". Likewise, the classification entitled "Material Tester II" involves the same job duties as the classification entitled "Material Tester/Inspector II".

2017 STREET IMPROVEMENTS  
VILLAGE OF VILLA PARK

APPENDIX 2  
IDOT STANDARD DRAWINGS

**NOT FOR BID**

ABV ABOVE  
A/C ACCESS CONTROL  
AC ACRE  
ADJ ADJUST  
AS AERIAL SURVEYS  
AGG AGGREGATE  
AH AHEAD  
APT APARTMENT  
ASPH ASPHALT  
AUX AUXILIARY  
AGS AUXILIARY GAS VALVE (SERVICE)  
AVE AVENUE  
AX AXIS OF ROTATION  
BK BACK  
B-B BACK TO BACK  
BKPL BACKPLATE  
B BARN  
BARR BARRICADE  
BCN BEGIN  
BM BENCHMARK  
BIND BINDER  
BIT BITUMINOUS  
BTM BOTTOM  
BLVD BOULEVARD  
BRK BRICK  
BBOX BUFFALO BOX  
BLDG BUILDING  
CIP CAST IRON PIPE  
CB CATCH BASIN  
C-C CENTER TO CENTER  
CL CENTERLINE OR CLEARANCE  
CL-E CENTERLINE TO EDGE  
CL-F CENTERLINE TO FACE  
CTS CENTERS  
CERT CERTIFIED  
CHSLD CHISELED  
CS CITY STREET  
CP CLAY PIPE  
CLSD CLOSED  
CLID CLOSED LID  
CT COAT OR COURT  
COMB COMBINATION  
C COMMERCIAL BUILDING  
CE COMMERCIAL ENTRANCE  
CONC CONCRETE  
CONST CONSTRUCT  
CONTD CONTINUED  
CONT CONTINUOUS  
COR CORNER  
CORR CORRUGATED  
CMP CORRUGATED METAL PIPE  
CNTY COUNTY  
CH COUNTY HIGHWAY  
CSE COURSE  
XSECT CROSS SECTION  
m<sup>3</sup> CUBIC METER  
mm<sup>3</sup> CUBIC MILLIMETER

CU YD CUBIC YARD  
CULV CULVERT  
C&G CURB & GUTTER  
D DEGREE OF CURVE  
DC DEPRESSED CURVE  
DET DETECTOR  
DIA DIAMETER  
DIST DISTRICT  
DOM DOMESTIC  
DBL DOUBLE  
DSEL DOWNSTREAM ELEVATION  
DSFL DOWNSTREAM FLOWLINE  
DR DRAINAGE OR DRIVE  
DI DRAINAGE INLET OR DROP INLET  
DRV DRIVEWAY  
DCT DUCT  
EA EACH  
EB EASTBOUND  
EOP EDGE OF PAVEMENT  
E-CL EDGE TO CENTERLINE  
E-E EDGE TO EDGE  
EL ELEVATION  
ENTR ENTRANCE  
EXC EXCAVATION  
EX EXISTING  
EXPWAY EXPRESSWAY  
E EXTERNAL DISTANCE OF HORIZONTAL CURVE  
E OFFSET DISTANCE TO VERTICAL CURVE  
F-F FACE TO FACE  
FA FEDERAL AID  
FAI FEDERAL AID INTERSTATE  
FAP FEDERAL AID PRIMARY  
FAS FEDERAL AID SECONDARY  
FAUS FEDERAL AID URBAN SECONDARY  
FP FENCE POST  
FE FIELD ENTRANCE  
FH FIRE HYDRANT  
FL FLOW LINE  
FB FOOT BRIDGE  
FDN FOUNDATION  
FR FRAME  
F&G FRAME & GRATE  
FRWAY FREEWAY  
GAL GALLON  
GALV GALVANIZED  
G GARAGE  
GM GAS METER  
GV GAS VALVE  
GRAN GRANULAR  
GR GRATE  
GRVL GRAVEL  
GND GROUND  
GUT GUTTER  
GP GUY POLE  
GW GUY WIRE  
HH HANDHOLE  
HATCH HATCHING

HD HEAD  
HDW HEADWALL  
HDUTY HEAVY DUTY  
ha HECTARE  
HMA HOT MIX ASPHALT  
HWY HIGHWAY  
HORIZ HORIZONTAL  
HSE HOUSE  
IL ILLINOIS  
IMP IMPROVEMENT  
IN DIA INCH DIAMETER  
INL INLET  
INST INSTALLATION  
IDS INTERSECTION DESIGN STUDY  
INV INVERT  
IP IRON PIPE  
IR IRON ROD  
JT JOINT  
kg KILOGRAM  
km KILOMETER  
LS LANDSCAPING  
LN LANE  
LT LEFT  
LP LIGHT POLE  
LGT LIGHTING  
LF LINEAL FEET OR LINEAR FEET  
L LITER OR CURVE LENGTH  
LC LONG CHORD  
LNG LONGITUDINAL  
L SUM LUMP SUM  
MACH MACHINE  
MB MAIL BOX  
MH MANHOLE  
MATL MATERIAL  
MED MEDIAN  
m METER  
METH METHOD  
M MID-ORDINATE  
mm MILLIMETER  
mm DIA MILLIMETER DIAMETER  
MIX MIXTURE  
MBH MOBILE HOME  
MOD MODIFIED  
MFT MOTOR FUEL TAX  
N & BC NAIL & BOTTLE CAP  
N & C NAIL & CAP  
N & W NAIL & WASHER  
NOAA NATIONAL OCEANIC ATMOSPHERIC ADMINISTRATION  
NC NORMAL CROWN  
NB NORTHBOUND  
NE NORTHEAST  
NW NORTHWEST  
OLID OPEN LID  
PAT PATTERN  
PVD PAVED  
PVMT PAVEMENT  
PM PAVEMENT MARKING

PED PEDESTAL  
PNT POINT  
PC POINT OF CURVATURE  
PI POINT OF INTERSECTION OF HORIZONTAL CURVE  
PRC POINT OF REVERSE CURVE  
PT POINT OF TANGENCY  
POT POINT ON TANGENT  
POLYETH POLYETHYLENE  
PCC PORTLAND CEMENT CONCRETE  
PP POWER POLE OR PRINCIPAL POINT  
PRM PRIME  
PE PRIVATE ENTRANCE  
PROF PROFILE  
PGL PROFILE GRADELINE  
PROJ PROJECT  
P.C. PROPERTY CORNER  
PL PROPERTY LINE  
PR PROPOSED  
R RADIUS  
RR RAILROAD  
RRS RAILROAD SPIKE  
RPS REFERENCE POINT STAKE  
REF REFLECTIVE  
RCCP REINFORCED CONCRETE CULVERT PIPE  
REINF REINFORCEMENT  
REM REMOVAL  
RC REMOVE CROWN  
REP REPLACEMENT  
REST RESTAURANT  
RESURF RESURFACING  
RET RETAINING  
RT RIGHT  
ROW RIGHT-OF-WAY  
RD ROAD  
RDWY ROADWAY  
RTE ROUTE  
SAN SANITARY  
SANS SANITARY SEWER  
SEC SECTION  
SEED SEEDING  
SHAP SHAPING  
S SHED  
SH SHEET  
SHLD SHOULDER  
SW SIDEWALK OR SOUTHWEST  
SIG SIGNAL  
SOD SODDING  
SM SOLID MEDIUM  
SB SOUTHBOUND  
SE SOUTHEAST  
SPL SPECIAL  
SD SPECIAL DITCH  
SQ FT SQUARE FEET  
m<sup>2</sup> SQUARE METER  
mm<sup>2</sup> SQUARE MILLIMETER  
SQ YD SQUARE YARD  
STB STABILIZED

STD STANDARD  
SBI STATE BOND ISSUE  
SR STATE ROUTE  
STA STATION  
SPBGR STEEL PLATE BEAM GUARDRAIL  
SS STORM SEWER  
STY STORY  
STR STREET  
STR STRUCTURE  
e SUPERELEVATION RATE  
S.E. RUN. SUPERELEVATION RUNOFF LENGTH  
SURF SURFACE  
SMK SURVEY MARKER  
T TANGENT DISTANCE  
T.R. TANGENT RUNOUT DISTANCE  
TEL TELEPHONE  
TB TELEPHONE BOX  
TP TELEPHONE POLE  
TEMP TEMPORARY  
TBM TEMPORARY BENCH MARK  
TDM TILE DRAIN  
TBE TO BE EXTENDED  
TBR TO BE REMOVED  
TBS TO BE SAVED  
TWP TOWNSHIP  
TR TROWNSHIP ROAD  
TS TRAFFIC SIGNAL  
TSCB TRAFFIC SIGNAL CONTROL BOX  
TSC TRAFFIC SYSTEMS CENTER  
TRVS TRANSVERSE  
TRVL TRAVEL  
TRN TURN  
TY TYPE  
T-A TYPE A  
TYP TYPICAL  
UNDGND UNDERGROUND  
USGS U.S. GEOLOGICAL SURVEY  
USEL UPSTREAM ELEVATION  
USFL UPSTREAM FLOWLINE  
UTIL UTILITY  
VBOX VALVE BOX  
VV VALVE VAULT  
VLT VAULT  
VEH VEHICLE  
VP VENT PIPE  
VERT VERTICAL  
VC VERTICAL CURVE  
VPC VERTICAL POINT OF CURVATURE  
VPI VERTICAL POINT OF INTERSECTION  
VPT VERTICAL POINT OF TANGENCY  
WMT WATER METER  
WM WATER VALVE  
WV WATER MAIN  
WMAIN WATER MAIN  
WB WESTBOUND  
WILDFL WILDFLOWERS  
W WITH  
WO WITHOUT

 Illinois Department of Transportation	
PASSED January 1, 2011 <i>Michael Beard</i> ENGINEER OF POLICY AND PROCEDURES	ISSUED 1-1-11 48-97
APPROVED January 1, 2011 <i>Scott Smith</i> ENGINEER OF DESIGN AND ENVIRONMENT	

DATE	REVISIONS
1-1-11	Updated abbreviations and symbols.
1-1-08	Updated abbreviations and symbols.

**STANDARD SYMBOLS,  
ABBREVIATIONS  
AND PATTERNS**

(Sheet 1 of 8)

**STANDARD 000001-06**

<b>ADJUSTMENT ITEMS</b>		<b>EX</b>	<b>PR</b>	<b>ALIGNMENT ITEMS</b>		<b>EX</b>	<b>PR</b>	<b>CONTOUR ITEMS</b>		<b>EX</b>	<b>PR</b>
Structure To Be Adjusted			ADJ	Baseline				Approx. Index Line			
Structure To Be Cleaned			C	Centerline				Approx. Intermediate Line			
Main Structure To Be Filled			FM	Centerline Break Circle	o		o	Index Contour			
Structure To Be Filled			F	Baseline Symbol				Intermediate Contour			
Structure To Be Filled Special			FSP	Centerline Symbol							
Structure To Be Removed			R	PI Indicator	△		△				
Structure To Be Reconstructed			REC	Point Indicator	o		o				
Structure To Be Reconstructed Special			RSP	Horizontal Curve Data (Half Size)	CURVE P.I. STA= Δ°= D= R= T= L= E= e= T.R.= S.E. RUN= P.C. STA= P.T. STA=		CURVE P.I. STA= Δ°= D= R= T= L= E= e= T.R.= S.E. RUN= P.C. STA= P.T. STA=				
Frame and Grate To Be Adjusted			A	<b>BOUNDARIES ITEMS</b>		<b>EX</b>	<b>PR</b>				
Frame and Lid To Be Adjusted			A	Dashed Property Line	- - - - -			Channel or Stream Line	- - - - -		
Domestic Service Box To Be Adjusted			A	Solid Property/Lot Line	_____			Culvert Line	- - - - -		
Valve Vault To Be Adjusted			A	Section/Grant Line	- - - - -			Grading & Shaping Ditches	- - - - -		
Special Adjustment			SP	Quarter Section Line	- - - - -			Drainage Boundary Line			
Item To Be Abandoned			AB	Quarter/Quarter Section Line	- - - - -			Paved Ditch			
Item To Be Moved			M	County/Township Line	- - - - -			Aggregate Ditch			
Item To Be Relocated			REL	State Line	- - - - -			Pipe Underdrain			
Pavement Removal and Replacement				Iron Pipe Found	o			Storm Sewer			
				Iron Pipe Set	•			Flowline			
				Survey Marker				Ditch Check			
				Property Line Symbol				Headwall	-		
				Same Ownership Symbol (Half Size)				Inlet	□		
				Northwest Quarter Corner (Half Size)				Manhole	o		
				Section Corner (Half Size)				Summit	↔		
				Southeast Quarter Corner (Half Size)				Roadway Ditch Flow			
								Swale			
								Catch Basin	o		
								Culvert End Section	◁		
								Water Surface Indicator			
								Riprap			

**STANDARD SYMBOLS,  
ABBREVIATIONS  
AND PATTERNS**

(Sheet 2 of 8)

**STANDARD 000001-06**

Illinois Department of Transportation

PASSED January 1, 2011

APPROVED January 1, 2011

ENGINEER OF DESIGN AND ENVIRONMENT

ISSUED 1-1-97

<b>EROSION &amp; SEDIMENT CONTROL ITEMS</b>		<b>EX</b>	<b>PR</b>	<b>NON-HIGHWAY IMPROVEMENT ITEMS</b>		<b>EX</b>	<b>PR</b>	<b>EXISTING LANDSCAPING ITEMS (contd.)</b>		<b>EX</b>	<b>PR</b>
Cleaning & Grading Limits				Noise Attn./Levee				Seeding Class 5			
Dike				Field Line				Seeding Class 7			
Erosion Control Fence				Fence				Seedlings Type 1			
Perimeter Erosion Barrier				Base of Levee				Seedlings Type 2			
Temporary Fence				Mailbox				Sodding			
Ditch Check Temporary				Multiple Mailboxes				Mowstake w/Sign			
Ditch Check Permanent				Pay Telephone				Tree Trunk Protection			
Inlet & Pipe Protection				Advertising Sign				Evergreen Tree			
Sediment Basin				<b>LANDSCAPING ITEMS</b>		<b>EX</b>	<b>PR</b>	Shade Tree			
Erosion Control Blanket				Contour Mounding Line				Duct			
Fabric Formed Concrete Revetment Mat				Fence				Conduit			
Turf Reinforcement Mat				Fence Post				Electrical Aerial Cable			
Mulch Temporary				Shrubs				Electrical Buried Cable			
Mulch Method 1				Mowline				Controller			
Mulch Method 2 Stabilized				Perennial Plants				Underpass Luminaire			
Mulch Method 3 Hydraulic				Seeding Class 2				Power Pole			
				Seeding Class 2A							
				Seeding Class 4							
				Seeding Class 4 & 5 Combined							

Illinois Department of Transportation  
 PASSED January 1, 2011  
 ENGINEER OF POLICY AND PROCEDURES  
 APPROVED January 1, 2011  
 ENGINEER OF DESIGN AND ENVIRONMENT

**STANDARD SYMBOLS, ABBREVIATIONS AND PATTERNS**  
 (Sheet 3 of 8)

STANDARD 000001-06



**PAVEMENT MARKINGS**

**(contd.)**

- Urban Combination Left
- Urban Combination Right
- Urban Left Turn Arrow
- Urban Right Turn Arrow
- Urban Left Turn Only
- Urban Right Turn Only
- Urban Thru Only
- Urban U-Turn
- Urban Combined U-Turn
- Rural Combination Left
- Rural Combination Right
- Rural Left Turn Arrow
- Rural Right Turn Arrow
- Rural Left Turn Only
- Rural Right Turn Only
- Rural Thru Only

**EX**

**PR**

NOT FOR BIDD

**RAILROAD ITEMS**

**EX**

**PR**

- Abandoned Railroad
- Railroad
- Railroad Point
- Control Box
- Crossing Gate
- Flashing Signal
- Railroad Cant. Mast Arm
- Crossbuck

**REMOVAL ITEMS**

**EX**

**PR**

- Removal Tic
- Bituminous Removal
- Hatch Pattern
- Tree Removal Single

**RIGHT OF WAY ITEMS**

**EX**

**PR**

- Future ROW Corner Monument
- ROW Marker
- ROW Line
- Easement
- Temporary Easement

Illinois Department of Transportation	
PASSED <u>          </u> January 1, <u>          </u> 2011 <i>Michael Beard</i> ENGINEER OF POLICY AND PROCEDURES	ISSUED 48" x 11"
APPROVED <u>          </u> January 1, <u>          </u> 2011 <i>Spencer</i> ENGINEER OF DESIGN AND ENVIRONMENT	

**STANDARD SYMBOLS,  
ABBREVIATIONS  
AND PATTERNS**

(Sheet 5 of 8)

**STANDARD 000001-06**

**RIGHT OF WAY ITEMS  
(contd.)**

	EX	PR
Access Control Line	— AC —	— AC —
Access Control Line & ROW	— AC —	— AC —
Access Control Line & ROW with Fence	— AR —	— AC —
Excess ROW Line		— XS —

**ROADWAY PLAN  
ITEMS**

	EX	PR
Cable Barrier	—○—○—○—○—	—■—■—■—■—
Concrete Barrier	—□—□—□—□—	—□—□—□—□—
Edge of Pavement	— — — — —	— — — — —
Bit Shoulders, Medians and C&G Line	— — — — —	— — — — —
Aggregate Shoulder	— — — — —	— — — — —
Sidewalks, Driveways	— — — — —	— — — — —
Guardrail	—□—□—□—□—	—■—■—■—■—
Guardrail Post	○	○
Traffic Sign	⊥	⊥
Corrugated Median		
Impact Attenuator		○○○○
North Arrow with District Office (Half Size)	N ↓ A	
Match Line		STA. 45+00
Slope Limit Line	— — — — —	
Typical Cross-Section Line	— — — — —	— — — — —

**ROADWAY PROFILES**

	EX	PR
P.I. Indicator	△	△
Point Indicator	○	○
Earthworks Balance Point		⊙
Begin Point		⊖
Vert. Curve Data	VPI = ELEV = L = E =	VPI = ELEV = L = E =
Ditch Profile Left Side	— — — — —	— — — — —
Ditch Profile Right Side	— — — — —	— — — — —
Roadway Profile Line	— — — — —	— — — — —
Storm Sewer Profile Left Side	— — — — —	— — — — —
Storm Sewer Profile Right Side	— — — — —	— — — — —

**SIGNING ITEMS**

	EX	PR
Cone, Drum or Barricade	○	○
Barricade Type II	▨	▨
Barricade Type III	▨	▨
Barricade With Edge Line	—○—	—○—
Flashing Light Sign	○	○
Panels I	▨	▨
Panels II	▨	▨
Direction of Traffic	→	→
Sign Flag (Half Size)	◇	◇

**SIGNING ITEMS  
(contd.)**

	EX	PR
Reverse Left W1-4L (Half Size)		⤴
Reverse Right W1-4R (Half Size)		⤵
Two Way Traffic Sign W6-3 (Half Size)		↕
Detour Ahead W20-2(0) (Half Size)		⤴
Left Lane Closed Ahead W20-5L(0) (Half Size)		⤴
Right Lane Closed Ahead W20-5R(0) (Half Size)		⤵
Road Closed Ahead W20-3(0) (Half Size)		⤴
Road Construction Ahead W20-1(0) (Half Size)		⤴
Single Lane Ahead (Half Size)		⤴
Transition Left W4-2L (Half Size)		↔
Transition Right W4-2R (Half Size)		↔

Illinois Department of Transportation

PASSED January 1, 2011

ENGINEER OF POLICY AND PROCEDURES

APPROVED January 1, 2011

ENGINEER OF DESIGN AND ENVIRONMENT

ISSUED 1-1-97

**STANDARD SYMBOLS,  
ABBREVIATIONS  
AND PATTERNS**

(Sheet 6 of 8)

**STANDARD 000001-06**

<u>SIGNING ITEMS</u> <u>(contd.)</u>		<u>EX</u>	<u>PR</u>	<u>STRUCTURES ITEMS</u>		<u>EX</u>	<u>PR</u>	<u>TRAFFIC SHEET ITEMS</u>		<u>EX</u>	<u>PR</u>
One Way Arrow Lrg. W1-6-(O) (Half Size)				Box Culvert Barrel	-----	-----		Cable Number			
Two Way Arrow Large W1-7-(O) (Half Size)				Box Culvert Headwall	-----	-----		Left Turn Green			
Detour M4-10L-(O) (Half Size)				Bridge Pier	-----	-----		Left Turn Yellow			
Detour M4-10R-(O) (Half Size)				Bridge	-----	-----		Signal Backplate			
One Way Left R6-1L (Half Size)				Retaining Wall	-----	-----		Signal Section 8" (200 mm)			
One Way Right R6-1R (Half Size)				Temporary Sheet Piling	-----	~~~~~		Signal Section 12" (300 mm)			
Left Turn Lane R3-1100L (Half Size)								Walk/Don't Walk Letters			
Keep Left R4-7AL (Half Size)								Walk/Don't Walk Symbols			
Keep Left R4-7BL (Half Size)								<u>TRAFFIC SIGNAL</u> <u>ITEMS</u>	<u>EX</u>	<u>PR</u>	
Keep Right R4-7AR (Half Size)								Galv. Steel Conduit	-----	-----	
Keep Right R4-7BR (Half Size)								Underground Cable	-----	-----	
Stop Here On Red R10-6-AL (Half Size)								Detector Loop Line	-----	-----	
Stop Here On Red R10-6-AR (Half Size)								Detector Loop Large			
No Left Turn R3-2 (Half Size)								Detector Loop Small			
No Right Turn R3-1 (Half Size)								Detector Loop Quadrapole			
Road Closed R11-2 (Half Size)											
Road Closed Thru Traffic R11-2 (Half Size)											

Illinois Department of Transportation

PASSED January 1, 2011  
*Michael Beard*  
 ENGINEER OF POLICY AND PROCEDURES

APPROVED January 1, 2011  
*Jeff Smith*  
 ENGINEER OF DESIGN AND ENVIRONMENT

ISSUED 487-1-1-97

**STANDARD SYMBOLS,  
 ABBREVIATIONS  
 AND PATTERNS**

(Sheet 7 of 8)

**STANDARD 000001-06**

<b>TRAFFIC SIGNAL ITEMS (contd.)</b>	<b>EX</b>	<b>PR</b>
Detector Raceway		
Aluminum Mast Arm		
Steel Mast Arm		
Veh. Detector Magnetic		
Conduit Splice		
Controller		
Gulfbox Junction		
Wood Pole		
Temp. Signal Head		
Handhole		
Double Handhole		
Heavy Duty Handhole		
Junction Box		
Ped. Pushbutton Detector		
Ped. Signal Head		
Power Pole Service		
Priority Veh. Detector		
Signal Head		
Signal Head w/Backplate		
Signal Post		
Closed Circuit TV		
Video Detector System		

<b>UNDERGROUND UTILITY ITEMS</b>	<b>EX</b>	<b>PR</b>	<b>ABANDONED</b>
Cable TV			
Electric Cable			
Fiber Optic			
Gas Pipe			
Oil Pipe			
Sanitary Sewer			
Telephone Cable			
Water Pipe			

<b>UTILITIES ITEMS</b>	<b>EX</b>	<b>PR</b>
Controller		
Double Handhole		
Fire Hydrant		
GuyWire or Deadman Anchor		
Handhole		
Heavy Duty Handhole		
Junction Box		
Light Pole		
Manhole		
Pipeline Warning Sign		
Power Pole		
Power Pole with Light		
Sanitary Sewer Cleanout		
Splice Box Above Ground		
Telephone Splice Box Above Ground		
Telephone Pole		

<b>UTILITY ITEMS (contd.)</b>	<b>EX</b>	<b>PR</b>
Traffic Signal		
Traffic Signal Control Box		
Water Meter		
Water Meter Valve Box		
Profile Line		
Aerial Power Line		

<b>VEGETATION ITEMS</b>	<b>EX</b>	<b>PR</b>
Deciduous Tree		
Bush or Shrub		
Evergreen Tree		
Stump		
Orchard/Nursery Line		
Vegetation Line		
Woods & Bush Line		

<b>WATER FEATURE ITEMS</b>	<b>EX</b>	<b>PR</b>
Stream or Drainage Ditch		
Waters Edge		
Water Surface Indicator		
Water Point		
Disappearing Ditch		
Marsh		
Marsh/Swamp Boundary		

Illinois Department of Transportation

PASSED January 1, 2011

ENGINEER OF POLICY AND PROCEDURES

APPROVED January 1, 2011

ENGINEER OF DESIGN AND ENVIRONMENT

ISSUED 1-1-11

**STANDARD SYMBOLS, ABBREVIATIONS AND PATTERNS**

(Sheet 8 of 8)

**STANDARD 000001-06**

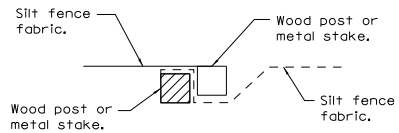

Place end-post (stake) of first silt fence adjacent to end-post (stake) of second silt fence with fabric positioned as shown.

**STEP 1**

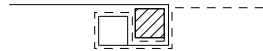

Rotate posts (stakes) together 180° clockwise and drive both posts (stakes) 18 (450) into ground.

**STEP 2**

**ATTACHING TWO SILT FILTER FENCES**  
(Not applicable for J-hooks)

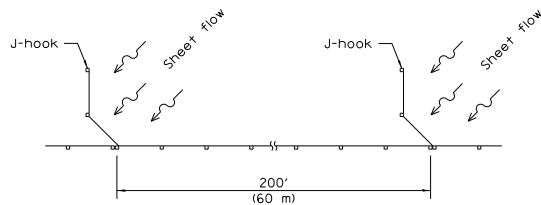

**SILT FILTER J-HOOK PLACEMENT**

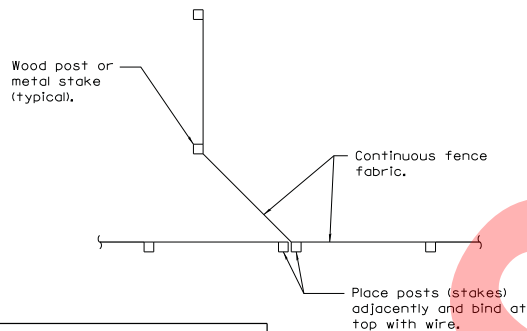

**J-HOOK**

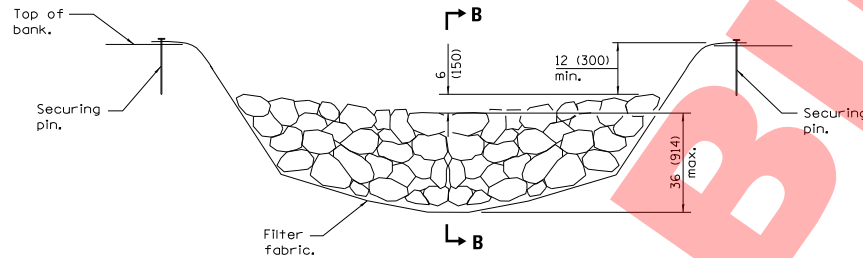

• When the ditch check is within the clear zone and the road is open to traffic, the traffic approach slope of the aggregate shall be 1:4 (V:H).

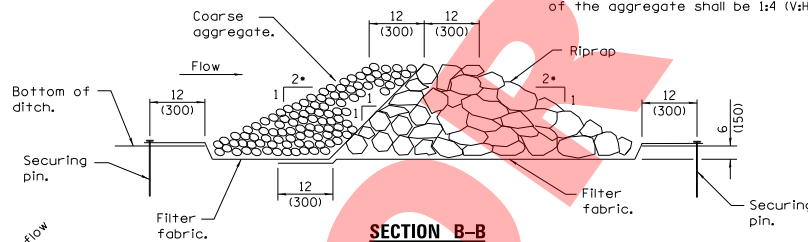

**SECTION B-B**  
**AGGREGATE DITCH CHECK**

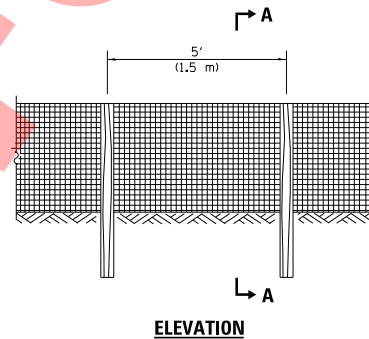

**SILT FILTER FENCE AS A PERIMETER EROSION BARRIER**

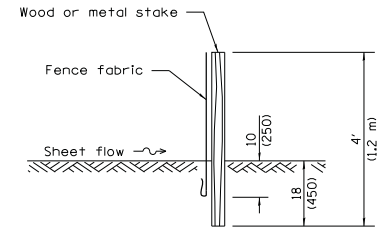

**SLICE METHOD**

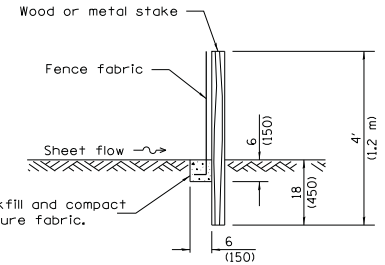

**TRENCH METHOD**

**SECTION A-A**

**GENERAL NOTES**

The installation details and dimensions shown for perimeter erosion barriers shall also apply for inlet and pipe protection.

All dimensions are in inches (millimeters) unless otherwise shown.

DATE	REVISIONS
1-1-13	Corrected notation for flowline (E) on SEDIMENT BASIN ELEVATION.
1-1-12	Omitted hay/straw perimeter barrier. Added SLICE METHOD to SECTION A-A.

**TEMPORARY EROSION CONTROL SYSTEMS**

(Sheet 1 of 2)

**STANDARD 280001-07**

Illinois Department of Transportation

PASSED January 1, 2013  
*Michael Beard*  
 ENGINEER OF POLICY AND PROCEDURES

APPROVED January 1, 2013  
*[Signature]*  
 ENGINEER OF DESIGN AND ENVIRONMENT

ISSUED 48-1-1-197

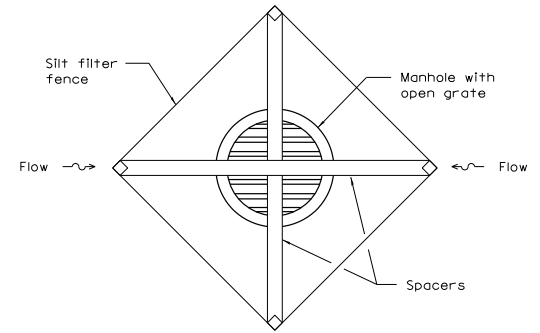
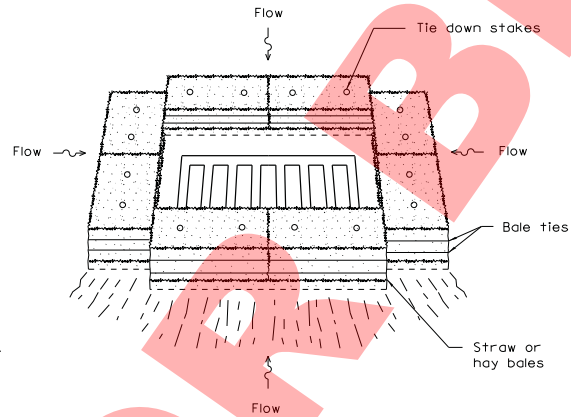
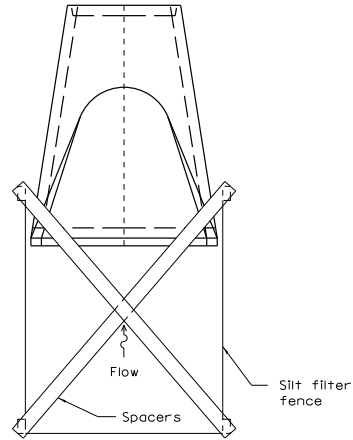
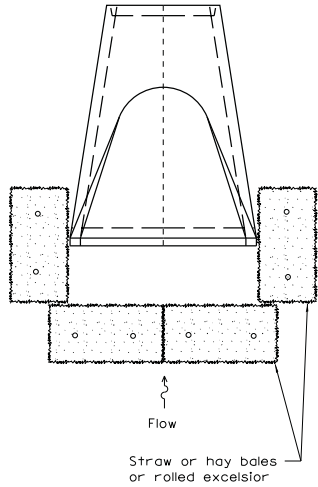

**INLET AND PIPE PROTECTION**

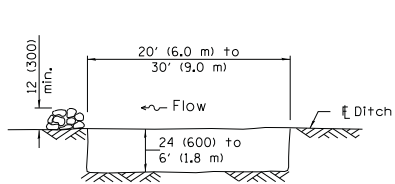

The performance of the basin will improve if put into a series.

**ELEVATION**

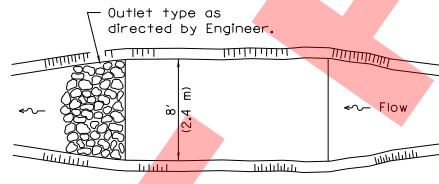

The long dimension should be parallel with the direction of the flow. Accumulated silt shall be removed anytime the basins become 75% filled.

**PLAN**

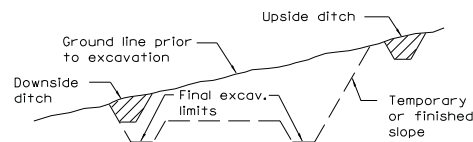

**TYPICAL CUT CROSS-SECTION**

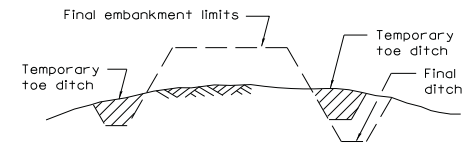

**TYPICAL FILL CROSS-SECTION**

**TEMPORARY DITCHES FOR CUT & FILL SECTIONS**

**SEDIMENT BASIN**

Illinois Department of Transportation	
PASSED	January 1, 2013
<i>Michael Beard</i>	
ENGINEER OF POLICY AND PROCEDURES	
APPROVED	January 1, 2013
<i>RE</i>	
ENGINEER OF DESIGN AND ENVIRONMENT	
ISSUED	44-1-1-197

**TEMPORARY EROSION CONTROL SYSTEMS**

(Sheet 2 of 2)

STANDARD 280001-07

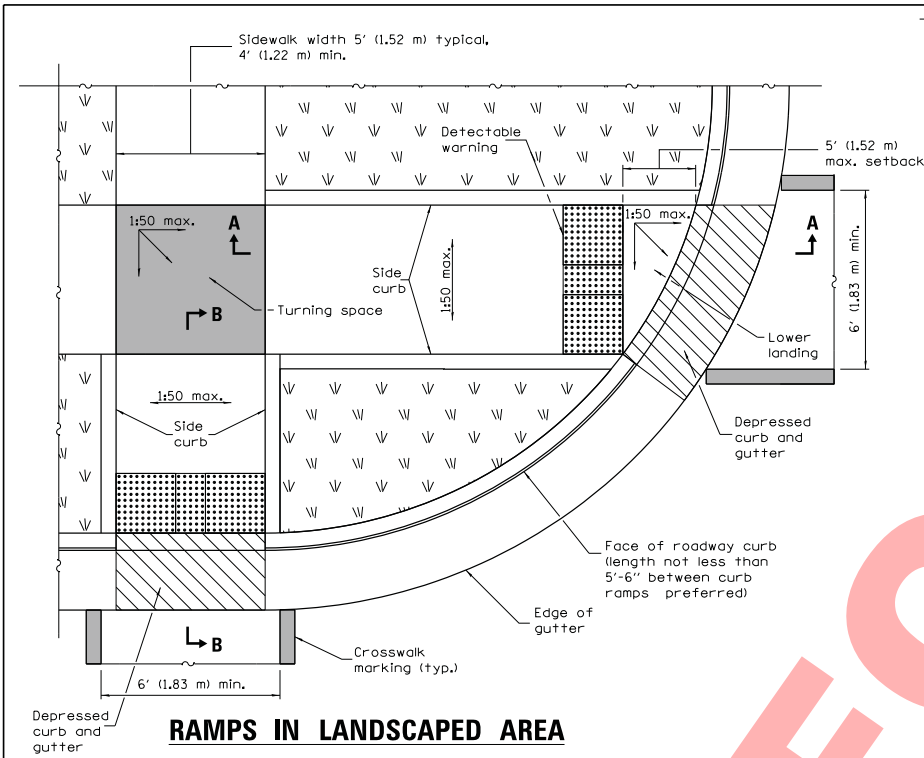

**RAMPS IN LANDSCAPED AREA**  
**SETBACK ≤ 5'**

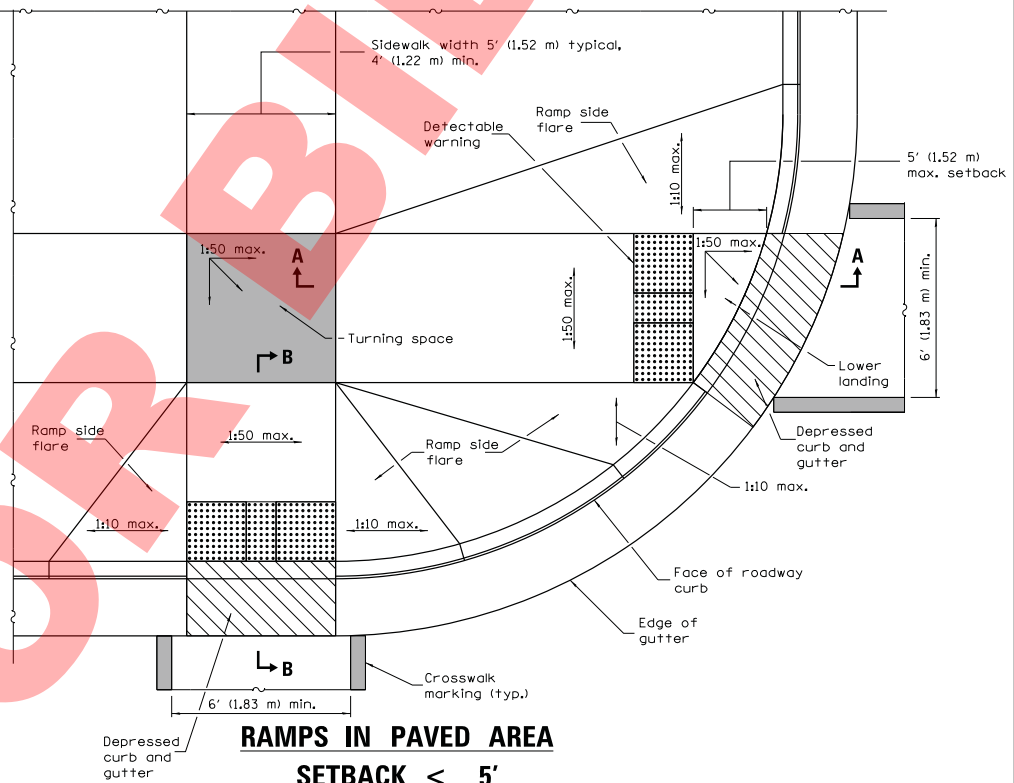

**RAMPS IN PAVED AREA**  
**SETBACK ≤ 5'**

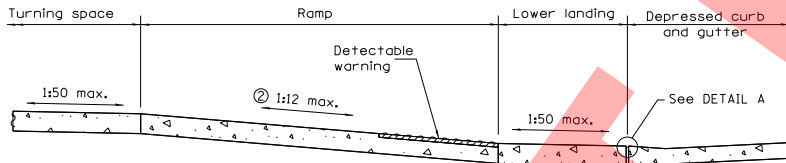

**SECTION A-A**

② The running slope of the curb ramp shall not require the ramp length to exceed 15' (4.5 m).

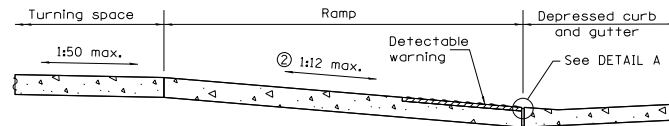

**SECTION B-B**

② The running slope of the curb ramp shall not require the ramp length to exceed 15' (4.5 m).

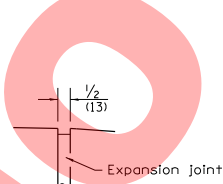

**DETAIL A**

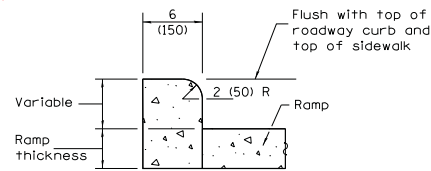

**SIDE CURB DETAIL**

See Sheet 2 for GENERAL NOTES.

Illinois Department of Transportation

PASSED January 1, 2017

ENGINEER OF POLICY AND PROCEDURES

APPROVED January 1, 2017

ENGINEER OF DESIGN AND ENVIRONMENT

DATE	REVISIONS
1-1-17	Added 2' dimension to det. warnings for setbacks greater than 5'.
1-1-15	① not appl. to int. sidewalks. Rev. gen. notes. Ch'd Upper landing to Turning space.

**PERPENDICULAR CURB RAMPS FOR SIDEWALKS**

(Sheet 1 of 2)

**STANDARD 424001-09**

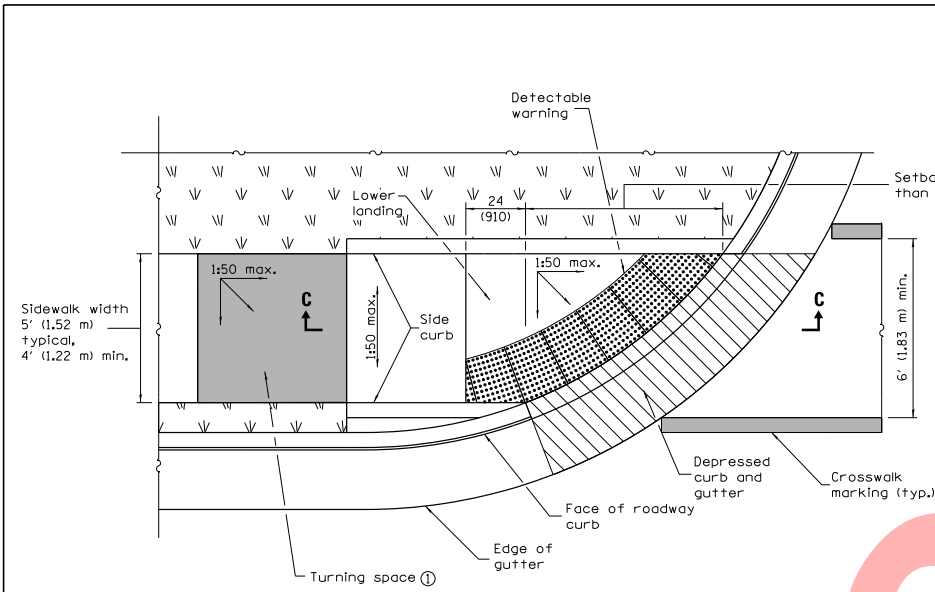

**RAMP IN LANDSCAPED AREA  
SETBACK > 5'**

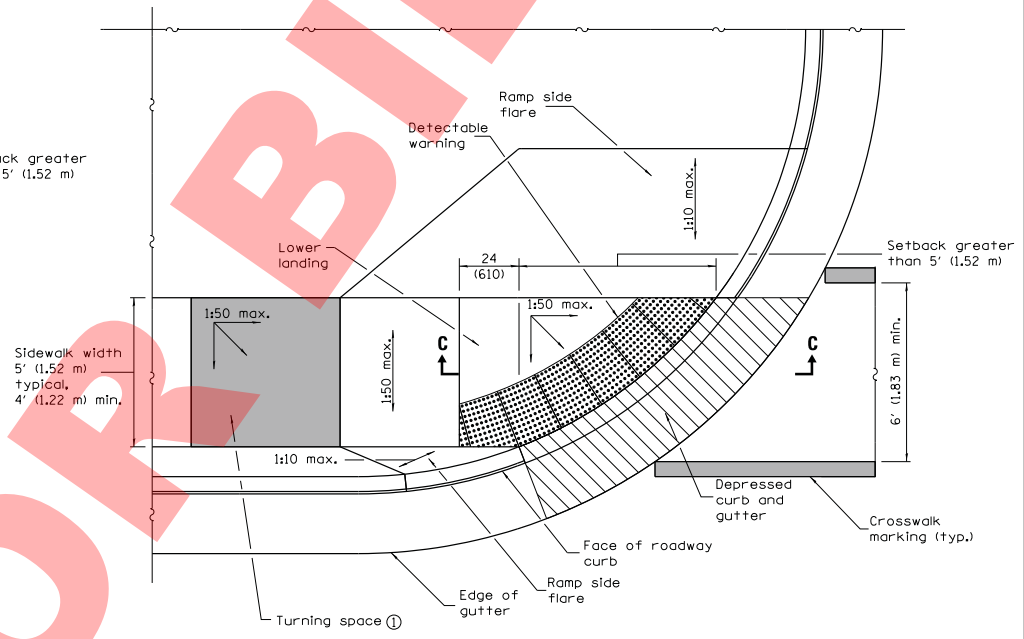

**RAMP IN PAVED AREA  
SETBACK > 5'**

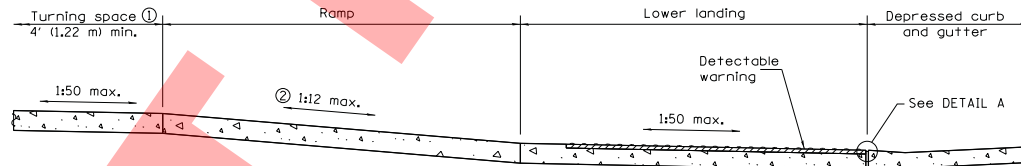

**SECTION C-C**

- ① Turning space not required for ramp slopes flatter than 1:20.
- ② The running slope of the curb ramp shall not require the ramp length to exceed 15' (4.5 m).

**GENERAL NOTES**

All slope ratios are expressed as units of vertical displacement to units of horizontal displacement (V:H).

Where the turning space is constrained on a side opposite a ramp, the minimum length of the turning space in the direction of the ramp-run shall be 5' (1.52 m).

Where 1:50 maximum slope is shown, 1:64 is preferred.

See Standard 606001 for details of depressed curb adjacent to curb ramp.

All dimensions are in inches (millimeters) unless otherwise shown.

**PERPENDICULAR CURB RAMPS  
FOR SIDEWALKS**

(Sheet 2 of 2)

**STANDARD 424001-09**

Illinois Department of Transportation	
PASSED	January 1, 2017
<i>Michael Beard</i>	
ENGINEER OF POLICY AND PROCEDURES	
APPROVED	January 1, 2017
<i>Maureen M. Behr</i>	
ENGINEER OF DESIGN AND ENVIRONMENT	
151515	46-1-1



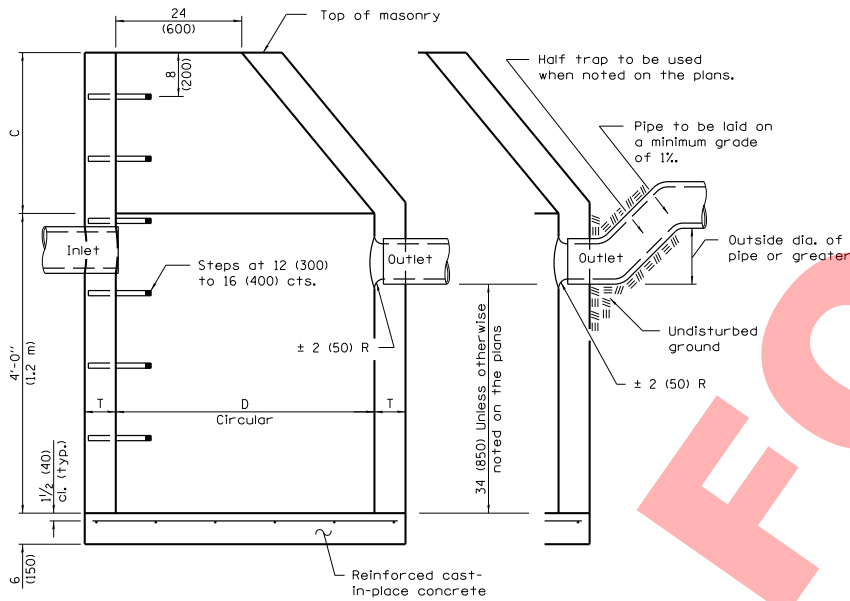

**ELEVATION**  
(Standard Outlet)

**ELEVATION**  
(Half Trap)

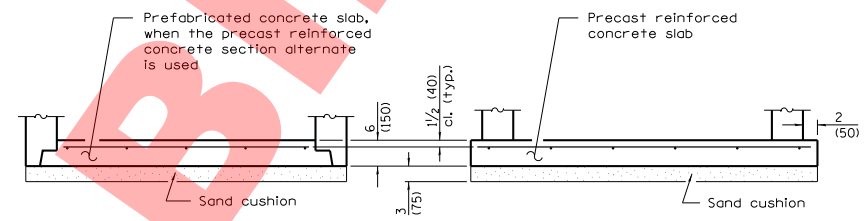

**ALTERNATE BOTTOM SLAB**

ALTERNATE MATERIALS FOR WALLS	D	C*	T (min.)
Concrete Masonry Unit	4'-0" (1.2 m)	30 (750)	5 (125)
	5'-0" (1.5 m)	3'-9" (1.15 m)	5 (125)
Brick Masonry	4'-0" (1.2 m)	30 (750)	8 (200)
	5'-0" (1.5 m)	3'-9" (1.15 m)	8 (200)
Precast Reinforced Concrete Section	4'-0" (1.2 m)	30 (750)	4 (100)
	5'-0" (1.5 m)	3'-9" (1.15 m)	5 (125)
Cast-in-place Concrete	4'-0" (1.2 m)	30 (750)	6 (150)
	5'-0" (1.5 m)	3'-9" (1.15 m)	6 (150)

\* For precast reinforced concrete sections, dimension "C" may vary from the dimension given to plus 6 (150).

**GENERAL NOTES**

Bottom slabs shall be reinforced with a minimum of 0.20 sq. in./ft (420 sq. mm/m) in both directions with a maximum spacing of 12 (300).

Bottom slabs may be connected to the riser as determined by the fabricator; however, only a single row of reinforcement around the perimeter may be utilized.

See Standard 602601 for optional precast reinforced concrete flat slab top.

See Standard 602701 for details of steps.

All dimensions are in inches (millimeters) unless otherwise shown.

DATE	REVISIONS
1-1-11	Added 'Outside' to half trap note. Detail rein. in slabs.
	Revised general notes.
1-1-09	Switched units to English (metric).

**CATCH BASIN  
TYPE A**

**STANDARD 602001-02**

Illinois Department of Transportation

PASSED January 1, 2011  
*Michael Beard*  
 ENGINEER OF POLICY AND PROCEDURES

APPROVED January 1, 2011  
*[Signature]*  
 ENGINEER OF DESIGN AND ENVIRONMENT

15815  
 46-1-1 03/15/11

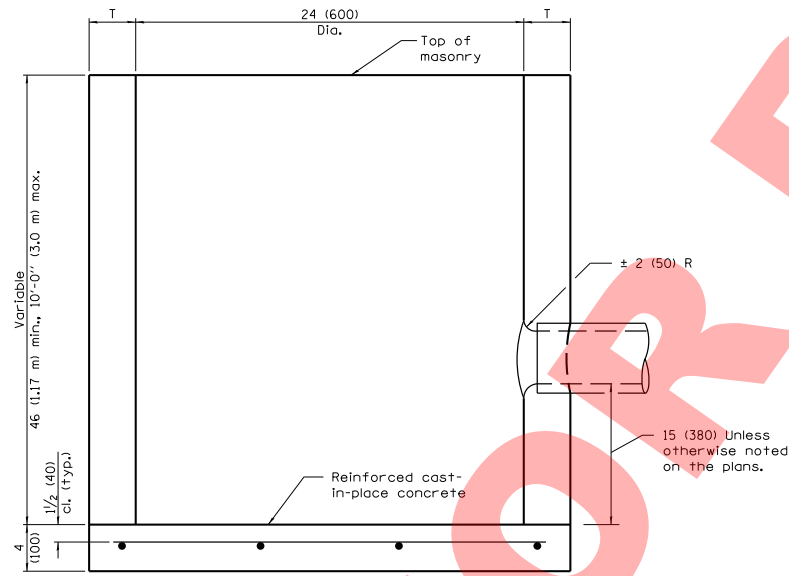

ALTERNATE MATERIALS FOR WALLS	T (min)
Precast Reinforced Concrete Section	3 (75)
Concrete Masonry Unit	5 (125)
Cast-in-Place Concrete	6 (150)
Brick Masonry	8 (200)

**ELEVATION**

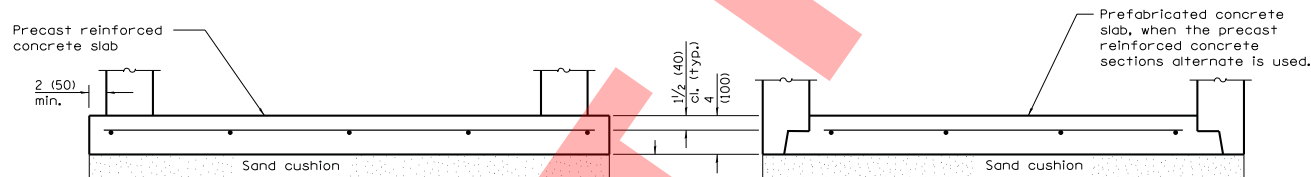

**ALTERNATE BOTTOM SLAB**

**GENERAL NOTES**

Bottom slabs shall be reinforced with a minimum of 0.27 sq. in./ft. (570 sq. mm/m) in both directions with a maximum spacing of 9 (230).

Bottom slabs may be connected to the riser as determined by the fabricator; however, only a single row of reinforcement around the perimeter may be utilized.

All dimensions are in inches (millimeters) unless otherwise shown.

Illinois Department of Transportation

PASSED January 1, 2011  
*Michael Beard*  
 ENGINEER OF POLICY AND PROCEDURES

APPROVED January 1, 2011  
*Spencer*  
 ENGINEER OF DESIGN AND ENVIRONMENT

158153  
 46-1-1 02/15/11

DATE	REVISIONS
1-1-11	Detailed rein. in slabs.
	Added max. limit to height.
	Added general notes.
1-1-09	Switched units to
	English (metric).

**CATCH BASIN TYPE C**

**STANDARD 602011-02**

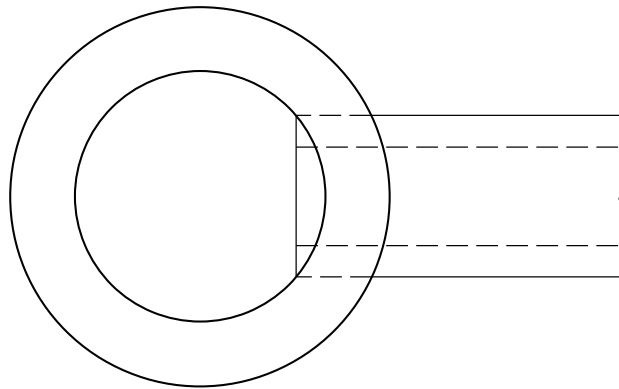

**PLAN**

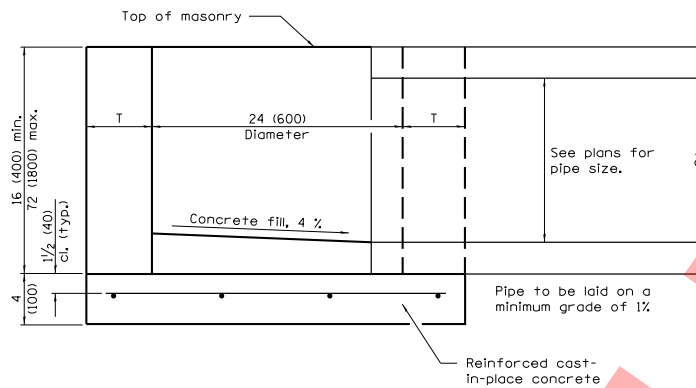

**ELEVATION**

ALTERNATE MATERIALS FOR WALLS	T
BRICK MASONRY	8 (200)
CAST-IN-PLACE CONCRETE	6 (150)
CONCRETE MASONRY UNIT	5 (125)
PRECAST REINFORCED CONCRETE SECTION	3 (75)

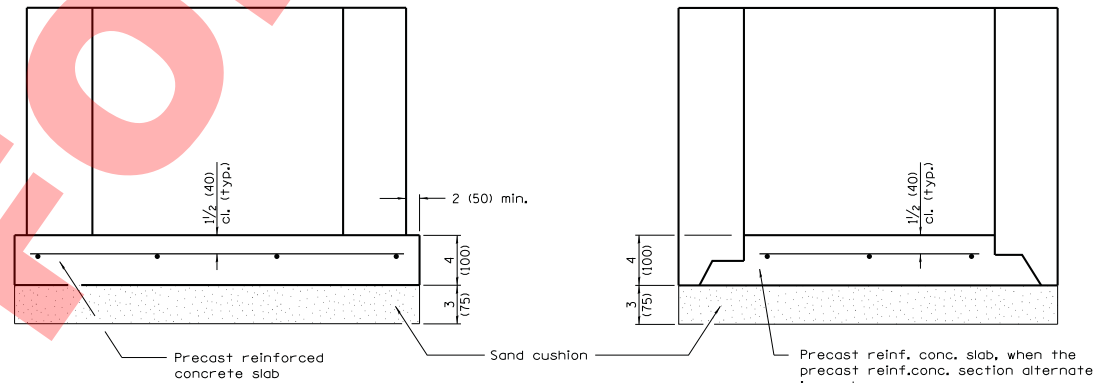

**ALTERNATE METHODS**

**GENERAL NOTES**

Bottom slabs shall be reinforced with a minimum of 0.24 sq. in./ft. (510 sq. mm/m) in both directions with a maximum spacing of 10 (250).

Bottom slabs may be connected to the riser as determined by the fabricator; however, only a single row of reinforcement around the perimeter may be utilized.

All dimensions are in inches (millimeters) unless otherwise shown.

DATE	REVISIONS
1-1-14	Increased height to 72 (1800) maximum.
1-1-11	Detailed rein. in slabs.
	Added max. limit to height.
	Added general notes.

**INLET – TYPE A**

**STANDARD 602301-04**

Illinois Department of Transportation

PASSED January 1, 2014

ENGINEER OF POLICY AND PROCEDURES

APPROVED January 1, 2014

ENGINEER OF DESIGN AND ENVIRONMENT

15815

46-1-1 03/ISS

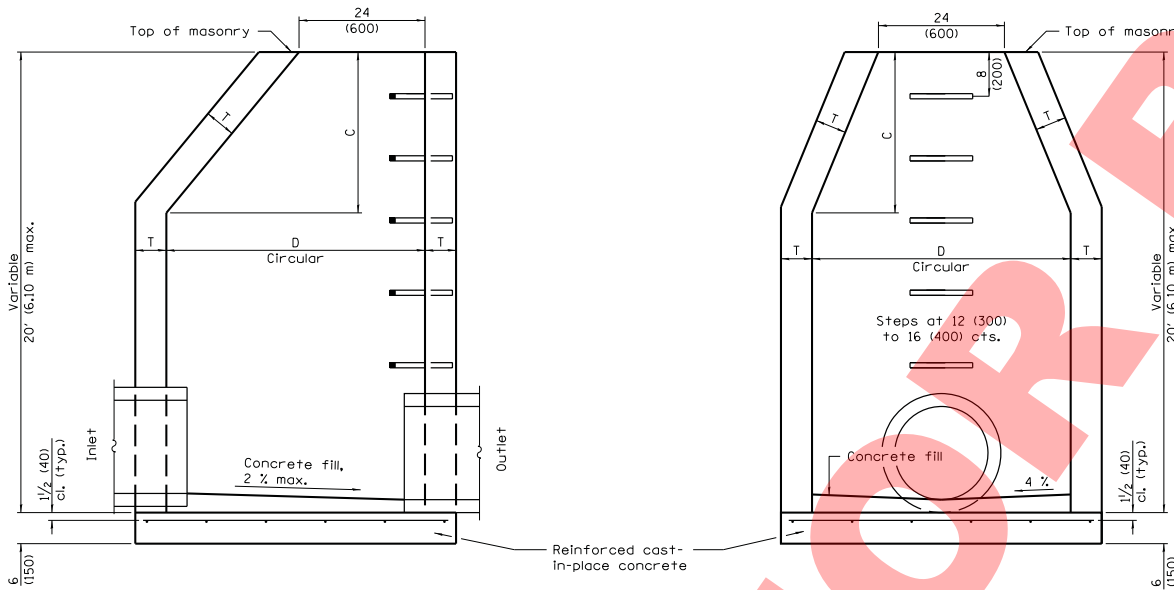

**ELEVATION - ECCENTRIC**

**ELEVATION - CONCENTRIC**

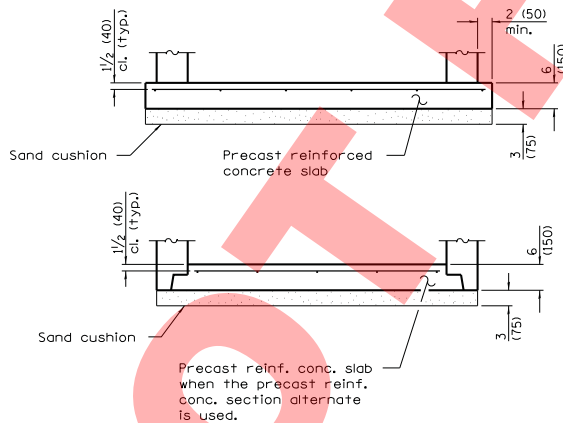

**ALTERNATE BOTTOM SLAB**

ALTERNATE MATERIALS FOR WALLS	D	C*	T (min.)
Concrete Masonry Unit	4'-0" (1.2 m)	30 (750)	5 (125)
	5'-0" (1.5 m)	3'-9" (1.15 m)	5 (125)
Brick Masonry	4'-0" (1.2 m)	30 (750)	8 (200)
	5'-0" (1.5 m)	3'-9" (1.15 m)	8 (200)
Precast Reinforced Concrete Section	4'-0" (1.2 m)	30 (750)	4 (100)
	5'-0" (1.5 m)	3'-9" (1.15 m)	5 (125)
Cast-in-place Concrete	4'-0" (1.2 m)	30 (750)	6 (150)
	5'-0" (1.5 m)	3'-9" (1.15 m)	6 (150)

\* For precast reinforced concrete sections, dimension "C" may vary from the dimension given to plus 6 (150).

**GENERAL NOTES**

Bottom slabs shall be reinforced with a minimum of 0.31 sq. in./ft. (660 sq. mm/m) in both directions with a maximum spacing of 12 (300).

Bottom slabs may be connected to the riser as determined by the fabricator; however, only a single row of reinforcement around the perimeter may be utilized.

See Standard 602701 for details of steps.

See Standard 602601 for optional Precast Reinforced Concrete Flat Slab Top.

All dimensions are in inches (millimeters) unless otherwise shown.

DATE	REVISIONS
1-1-11	Detailed reinf. in slabs.
	Added max. limit to height.
	Revised general notes.
1-1-09	Switched units to
	English (metric).

**MANHOLE TYPE A**

**STANDARD 602401-03**

Illinois Department of Transportation

PASSED January 1, 2011

ENGINEER OF POLICY AND PROCEDURES

APPROVED January 1, 2011

ENGINEER OF DESIGN AND ENVIRONMENT

158155

46-1-1 03/ISS

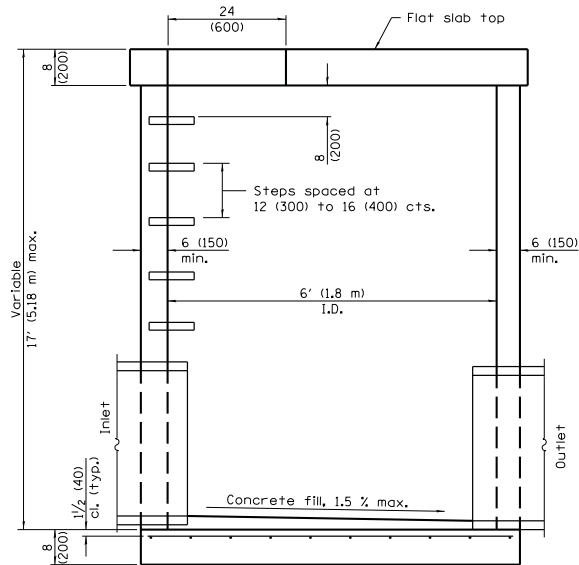

**ELEVATION**  
(with flat slab top only)

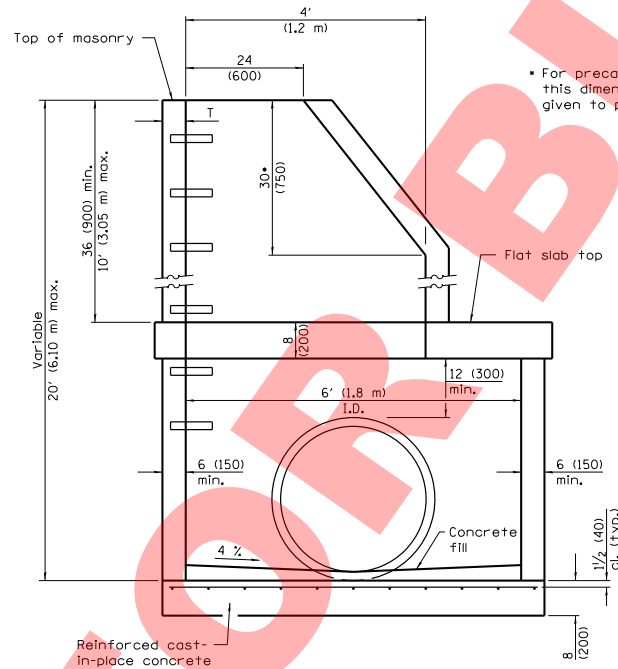

**ELEVATION**  
(with flat slab top and riser)

\* For precast reinforced concrete sections, this dimension may vary from the dimension given to plus 6 (150).

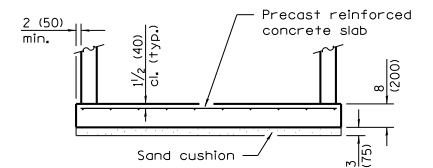
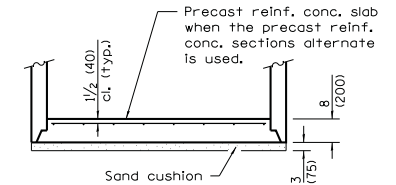

**ALTERNATE BOTTOM SLABS**

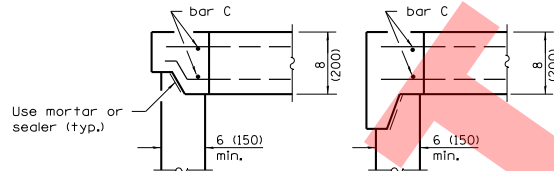

**ALTERNATE JOINT CONFIGURATIONS**

ALTERNATE MATERIALS FOR WALLS	T (min)
Concrete Masonry Units	5 (125)
Precast Reinforced Concrete Sections	4 (100)
Cast-In-Place Concrete	6 (150)

**GENERAL NOTES**

Joint configuration and dimensions of flat slab top shall match and fit the riser joint detail.

Bottom slabs shall be reinforced with a minimum of 0.29 sq. in./ft. (610 sq. mm /m) in both directions with a maximum spacing of 13 (330).

Bottom slabs may be connected to the riser as determined by the fabricator; however, only a single row of reinforcement around the perimeter may be utilized.

See Standard 602701 for details of manhole steps.

All dimensions are in inches (millimeters) unless otherwise shown.

DATE	REVISIONS
4-1-16	Changed terminology to 'welded wire reinforcement'.
1-1-14	Increased maximum heights.
	Revised General Notes.

**MANHOLE TYPE A**  
**6' (1.8 m) DIAMETER**

(Sheet 1 of 2)

**STANDARD 602406-07**

Illinois Department of Transportation

PASSED April 1, 2016

Michael Beard  
ENGINEER OF POLICY AND PROCEDURES

APPROVED April 1, 2016

ENGINEER OF DESIGN AND ENVIRONMENT

ISSUED 44-1-1

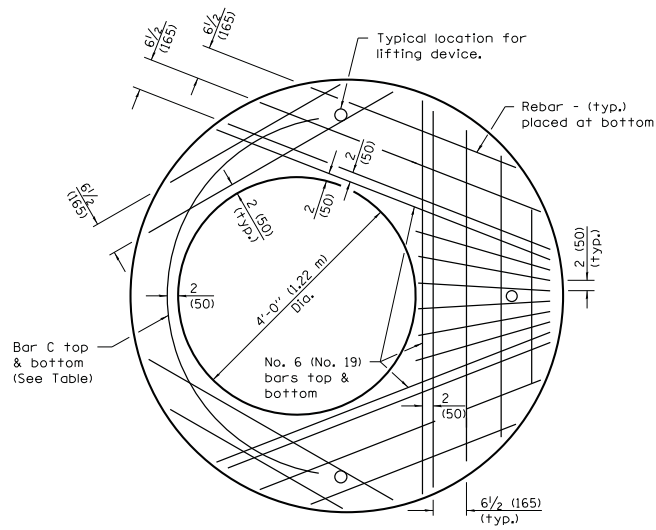

**PLAN**  
Showing Rebar Reinforcement

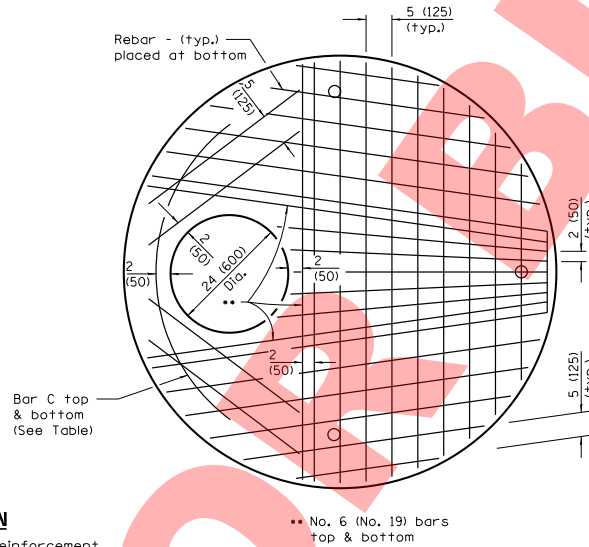

**PLAN**  
Showing Welded Wire Fabric Reinforcement

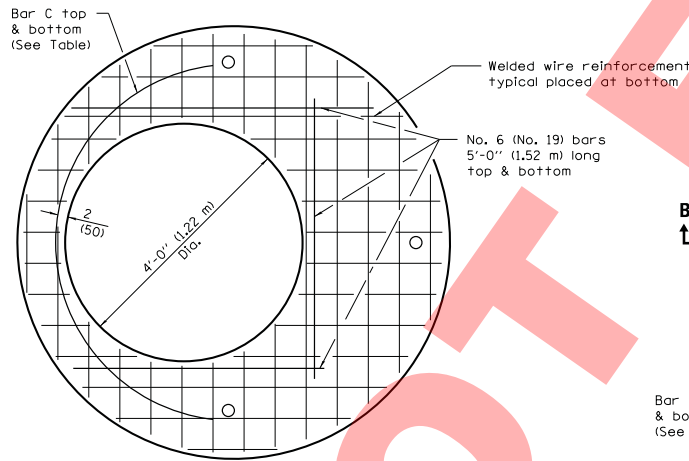

**PLAN**  
Showing Welded Wire Fabric Reinforcement

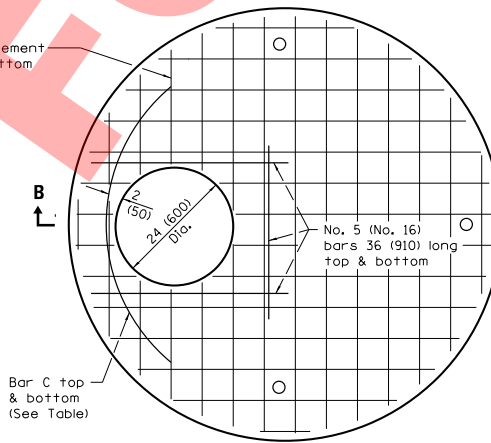

**PLAN**  
Showing Welded Wire Fabric Reinforcement

Diameter of opening	Thickness	Reinforcement "As" WWR Each direction	Bar Size	No. 4 (No. 13) Bar C	
				Length	Radius
24 (600)	8 (200)	1.06 sq. in./ft. (2244 sq. mm/m)	No. 6 (No. 19)	6'-0" (1.83 m)	38 (965)
4'-0" (1.2 m)	8 (200)	0.82 sq. in./ft. (1736 sq. mm/m)	No. 6 (No. 19)	9'-0" (2.74 m)	38 (965)

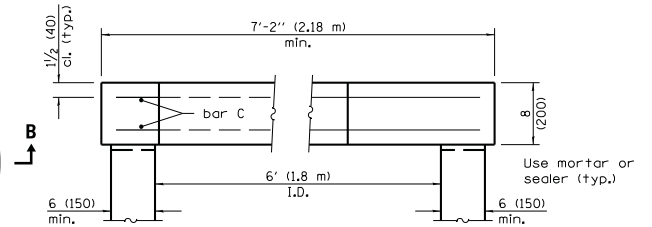

**SECTION B-B**

Illinois Department of Transportation

PASSED April 1, 2016

ENGINEER OF POLICY AND PROCEDURES  
*Michael Beard*

APPROVED April 1, 2016

ENGINEER OF DESIGN AND ENVIRONMENT

158PSS  
48-1-1-197

**MANHOLE TYPE A**  
**6' (1.8 m) DIAMETER**

(Sheet 2 of 2)

**STANDARD 602406-07**

• For precast reinforced concrete sections, this dimension may vary from the dimension given to plus 6 (150).

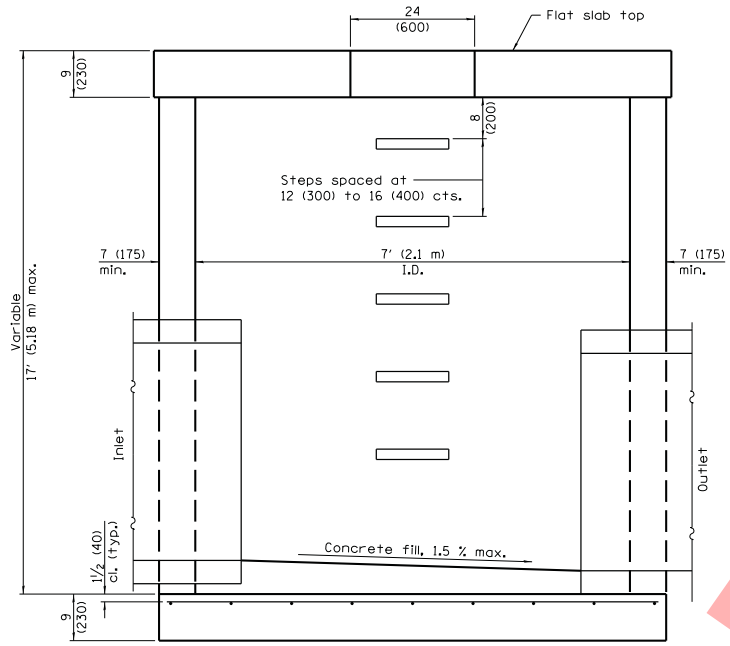

**ELEVATION**  
(With Flat Slab Top Only)

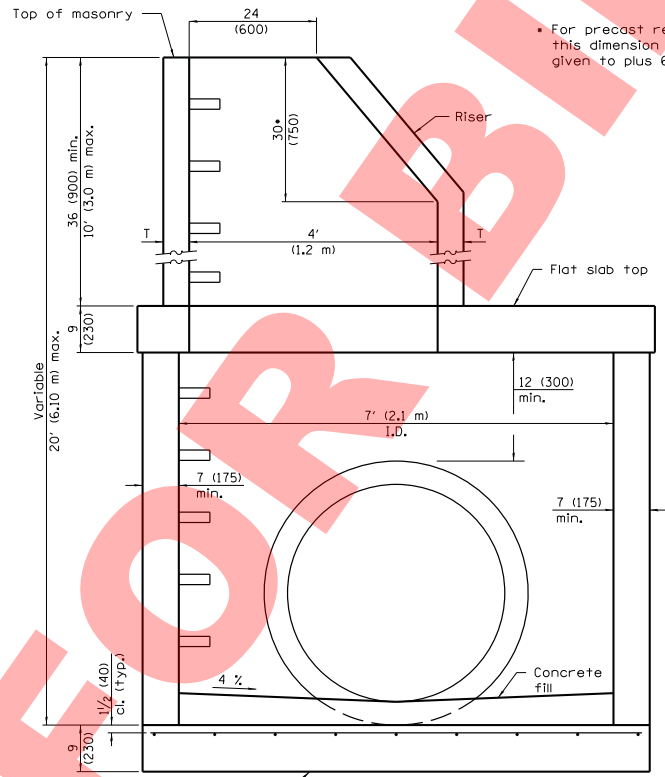

**ELEVATION**  
(With Flat Slab Top and Riser)

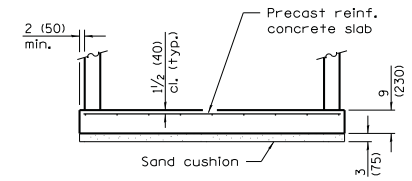
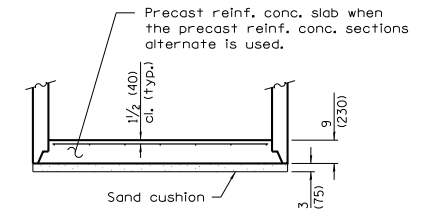

**ALTERNATE BOTTOM SLABS**

**GENERAL NOTES**

Joint configuration and dimensions of flat slab top shall match and fit the riser joint detail.

Bottom slabs shall be reinforced with a minimum of 0.31 sq. in./ft. (660 sq. mm/m) in both directions with a maximum spacing of 12 (300).

Bottom slabs may be connected to the riser as determined by the fabricator; however, only a single row of reinforcement around the perimeter may be utilized.

See Standard 602701 for details of manhole steps.

All dimensions are in inches (millimeters) unless otherwise shown.

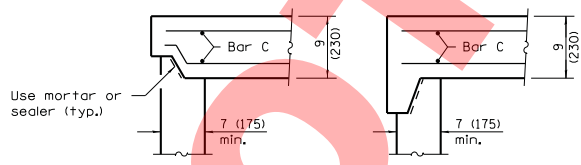

**ALTERNATE JOINT CONFIGURATIONS**

ALTERNATE MATERIALS FOR RISER WALLS	T (min)
Concrete Masonry Units	5 (125)
Precast Reinforced Concrete Sections	4 (100)
Cast-in-Place Concrete	6 (150)

DATE	REVISIONS
4-1-16	Changed terminology to 'welded wire reinforcement'.
1-1-14	Increased maximum heights.
	Revised General Notes.

**MANHOLE TYPE A**  
**7' (2.1 m) DIAMETER**

(Sheet 1 of 2)

**STANDARD 602411-05**

Illinois Department of Transportation

PASSED April 1, 2016

ENGINEER OF POLICY AND PROCEDURES

APPROVED April 1, 2016

ENGINEER OF DESIGN AND ENVIRONMENT

ISSUED 4-1-06



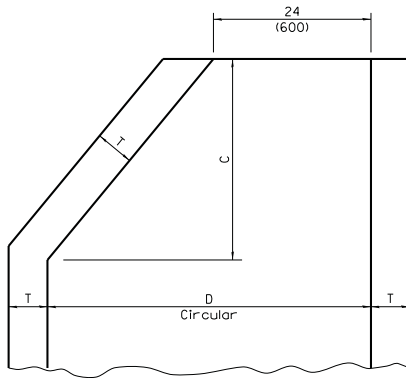

The cone of the valve vault shall be constructed as shown above only when there is interference with underground conditions and those conditions cannot be altered.

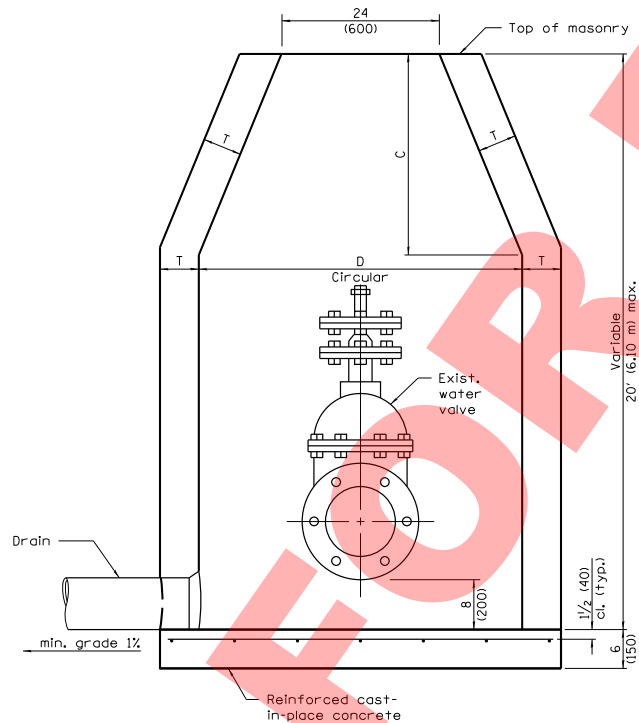

**ELEVATION**

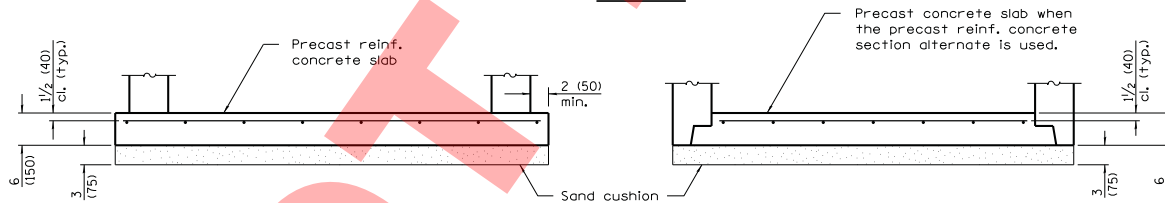

**ALTERNATE METHODS**

ALTERNATE MATERIALS FOR WALLS	D	C •	T (min.)
Concrete Masonry Unit	4'-0" (1.2 m)	30 (750)	5 (125)
	5'-0" (1.5 m)	3'-9" (1.15 m)	5 (125)
Brick Masonry	4'-0" (1.2 m)	30 (750)	8 (200)
	5'-0" (1.5 m)	3'-9" (1.15 m)	8 (200)
Precast Reinforced Concrete Section	4'-0" (1.2 m)	30 (750)	4 (100)
	5'-0" (1.5 m)	3'-9" (1.15 m)	5 (125)
Cast-in-Place Concrete	4'-0" (1.2 m)	30 (750)	6 (150)
	5'-0" (1.5 m)	3'-9" (1.15 m)	6 (150)

• For precast reinforced concrete sections, dimension "C" may vary from the dimension given to plus 6 (150).

DIAMETER OF WATER MAIN	D
8 (200) and under	4'-0" (1.2 m)
10 (250) and over	5'-0" (1.5 m)

**GENERAL NOTES**

Bottom slabs shall be reinforced with a minimum of 0.31 sq. in./ft. (660 sq. mm/m) in both directions with a maximum spacing of 12 (300).

Bottom slabs may be connected to the riser as determined by the fabricator; however, only a single row of reinforcement around the perimeter may be utilized.

See Standard 602601 for optional Precast Reinforced Concrete Flat Top Slab.

All dimensions are in inches (millimeters) unless otherwise shown.

DATE	REVISIONS
1-1-11	Detailed reinforcement in slabs. Revised general notes.
1-1-09	Switched units to English (metric).

**VALVE VAULT TYPE A**

**STANDARD 602501-02**

Illinois Department of Transportation

PASSED January 1, 2011  
*Michael Beard*  
 ENGINEER OF POLICY AND PROCEDURES

APPROVED January 1, 2011  
*Spencer*  
 ENGINEER OF DESIGN AND ENVIRONMENT

46-1-1 03/ISS1

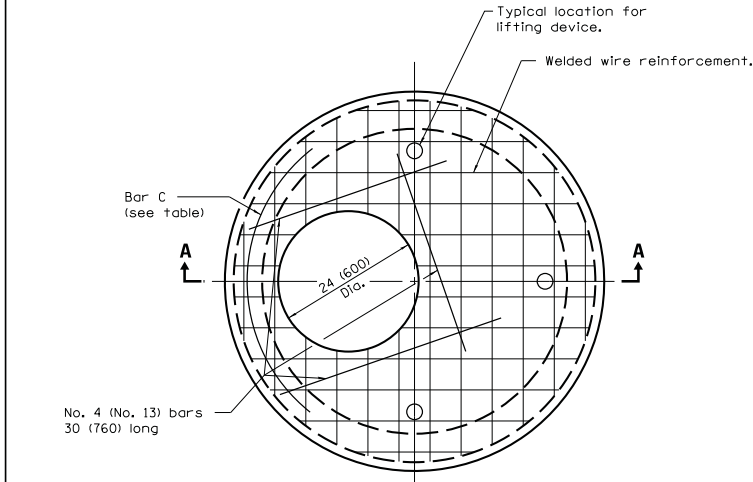

**PLAN**  
(WELDED WIRE FABRIC)

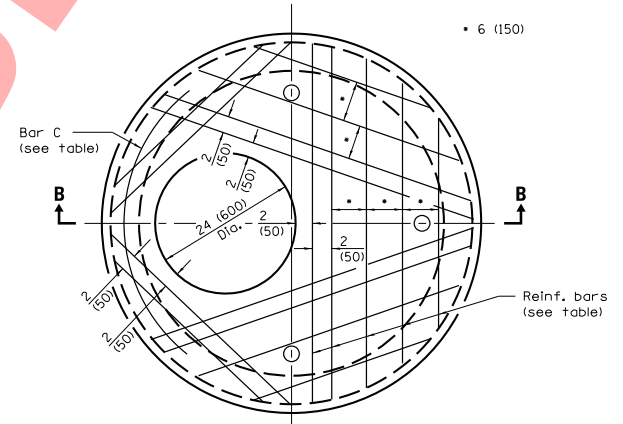

**PLAN**  
(REINFORCEMENT BARS)

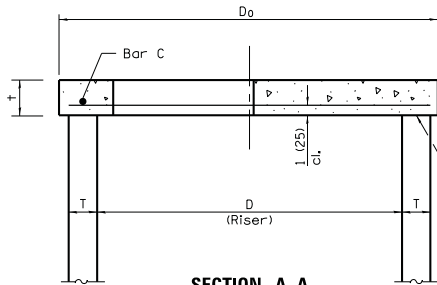

**SECTION A-A**

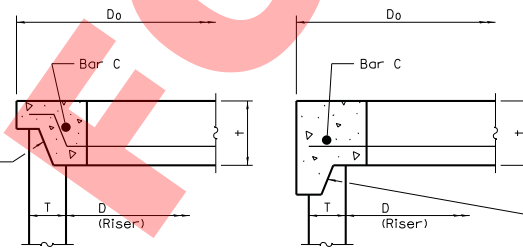

**ALTERNATE JOINT CONFIGURATIONS**

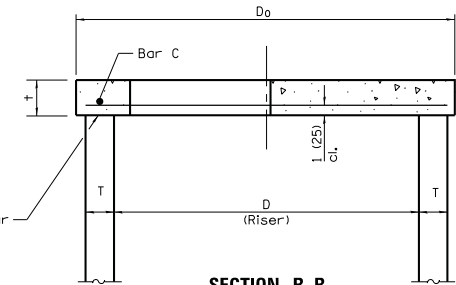

**SECTION B-B**

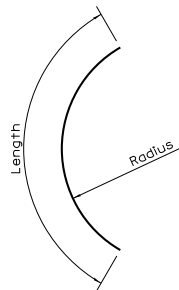

**BAR C**

**TABLE**

D	T	D <sub>o</sub> (min.)	†	Reinforcement		No. 4 (No. 13) Bar C	
				"A <sub>s</sub> " W.W.R. each direction	OR Bar size	Length	Radius
36 (900)			6 (150)	0.20 sq. in./ft. (425 sq. mm/m)	No. 4 (No. 13)	4'-0" (1.2 m)	19 (480)
4'-0" (1.2 m)			6 (150)	0.35 sq. in./ft. (740 sq. mm/m)	No. 5 (No. 16)	4'-6" (1.35 m)	26 (660)
5'-0" (1.5 m)			8 (200)	0.35 sq. in./ft. (740 sq. mm/m)	No. 5 (No. 16)	5'-0" (1.5 m)	32 (810)

**GENERAL NOTES**

The flat slab top may be used in lieu of the tapered tops shown on Standards 602001, 602011, 602016, 602306, 602401, or 602501 at the option of the Contractor or when field conditions prohibit the use of tapered tops.

All dimensions are in millimeters (inches) unless otherwise shown.

DATE	REVISIONS
4-1-16	Changed terminology to 'welded wire reinforcement'.
1-1-14	Omitted detail for lifting hole or lifting loop.

**PRECAST REINFORCED  
CONCRETE FLAT SLAB TOP**

**STANDARD 602601-04**

Illinois Department of Transportation

PASSED April 1, 2016

ENGINEER OF POLICY AND PROCEDURES

APPROVED April 1, 2016

ENGINEER OF DESIGN AND ENVIRONMENT

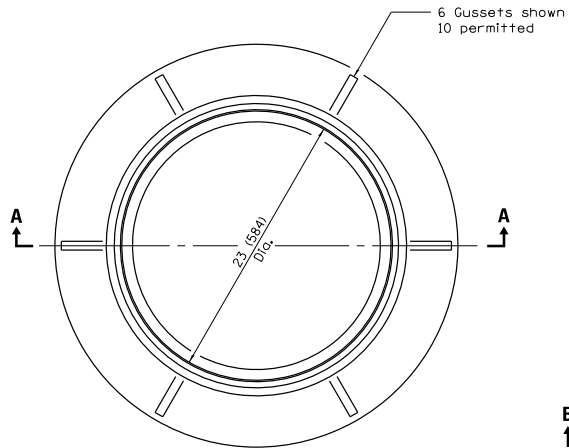

**CAST FRAME**

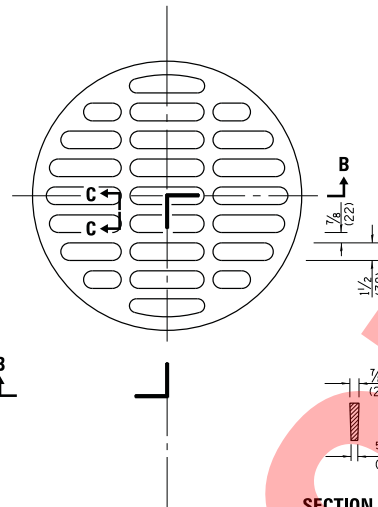

**SECTION C-C**

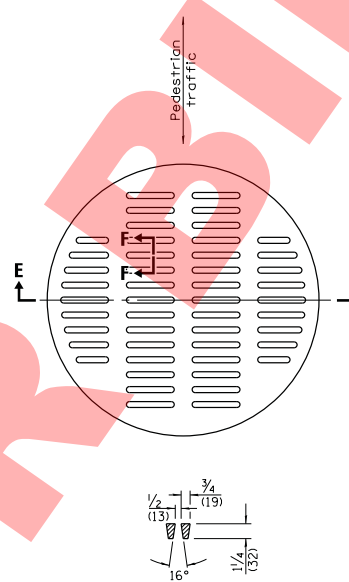

**SECTION F-F**

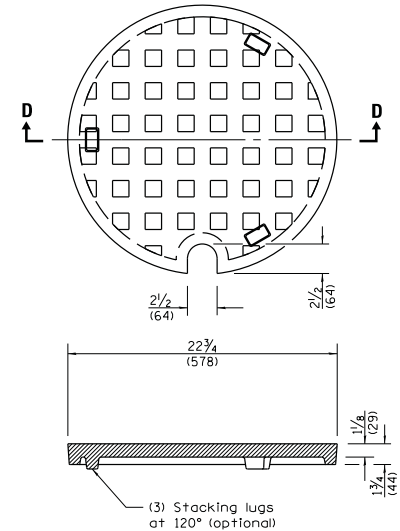

**SECTION D-D**

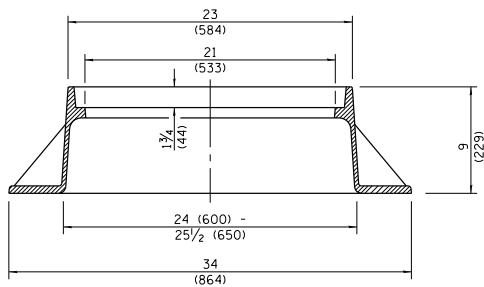

**SECTION A-A**  
Gray Iron

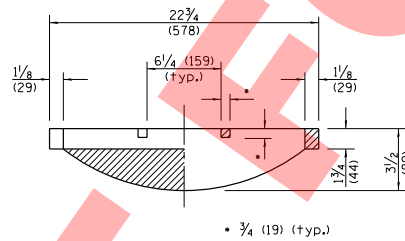

**SECTION B-B**

**CAST OPEN LID**

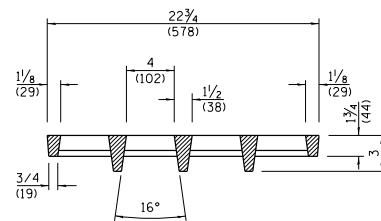

**SECTION E-E**

**ADA COMPLIANT  
CAST OPEN LID**

**CAST CLOSED LID**  
Gray Iron Lid

All dimensions are in inches (millimeters) unless otherwise shown.

Illinois Department of Transportation	
PASSED	January 1, 2015
ENGINEER OF POLICY AND PROCEDURES <i>Michael Beard</i>	
APPROVED	January 1, 2015
ENGINEER OF DESIGN AND ENVIRONMENT	

DATE	REVISIONS
1-1-15	Revised dimensioning of frame. Added ADA compliant open lid.
1-1-09	Switched units to English (metric).

**FRAME AND LIDS  
TYPE 1**

**STANDARD 604001-04**

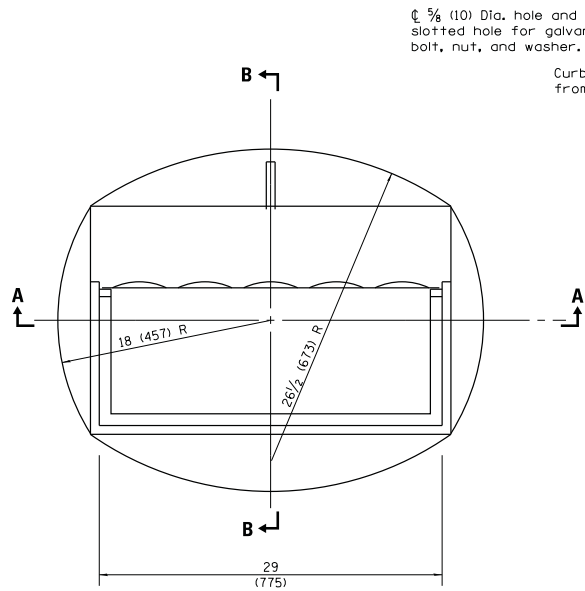

**CAST FRAME**

☐  $\frac{5}{8}$  (10) Dia. hole and  $\frac{5}{8} \times 5/2$  (16x140) slotted hole for galvanized  $1/2$  (M12) bolt, nut, and washer.

Curb box adjustable from  $4 1/2$  (115) to  $9$  (225)

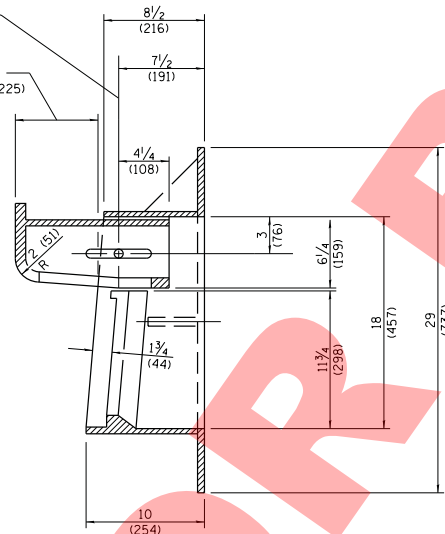

**SECTION B-B**

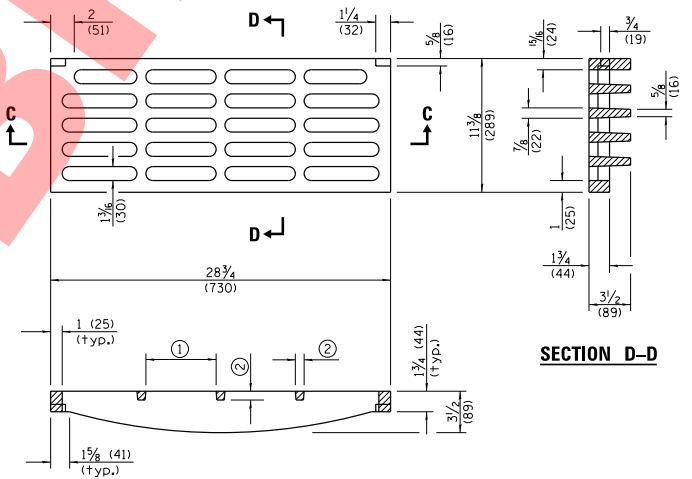

**SECTION C-C**

- ① =  $6/4$  (159) max. (typ.)
- ② =  $3/4$  (19) min. (typ.)

**SECTION D-D**

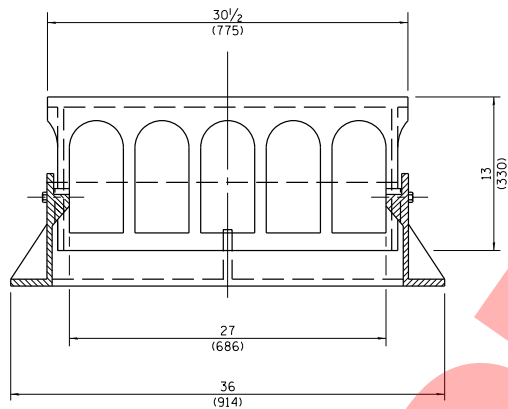

**SECTION A-A**

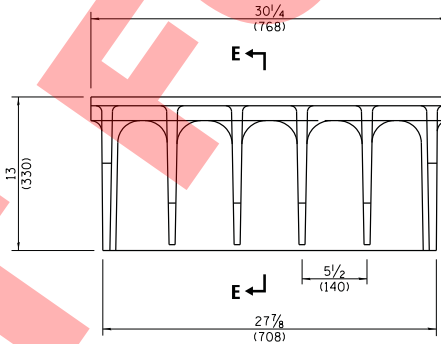

**ALTERNATE CURB BOX**

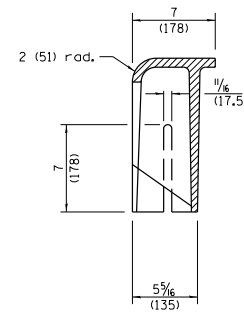

**SECTION E-E**

**CAST GRATE**

All dimensions are in inches (millimeters) unless otherwise shown.

Illinois Department of Transportation	
PASSED	January 1, 2015
ENGINEER OF POLICY AND PROCEDURES	
APPROVED	January 1, 2015
ENGINEER OF DESIGN AND ENVIRONMENT	

DATE	REVISIONS
1-1-15	Revised dimensions of frame and alternate curb box.
4-1-09	Switched units to English (metric).

**FRAME AND GRATE  
TYPE 11**

**STANDARD 604051-04**

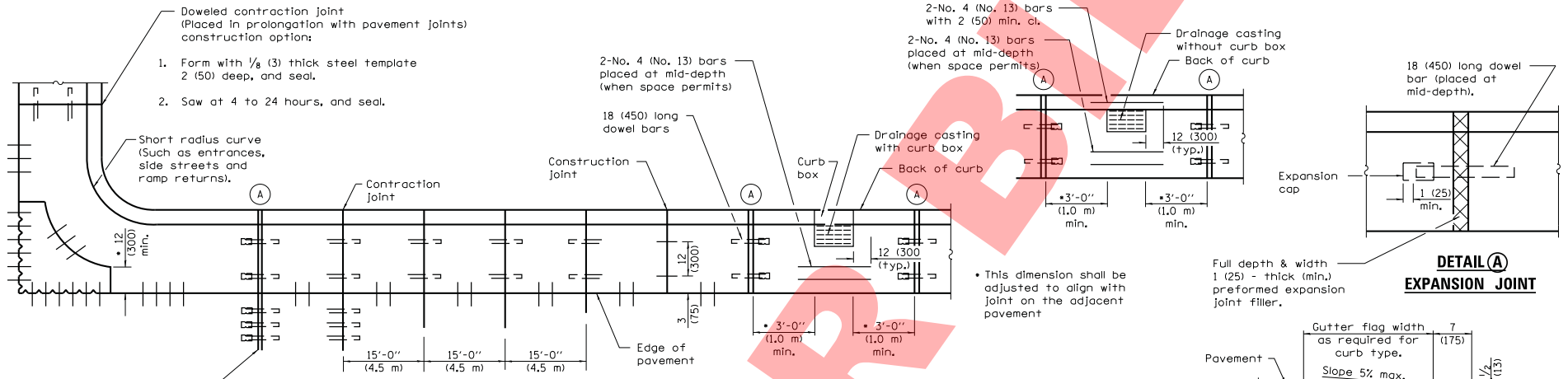

**PLAN**  
**ADJACENT TO PCC PAVEMENT OR PCC BASE COURSE**

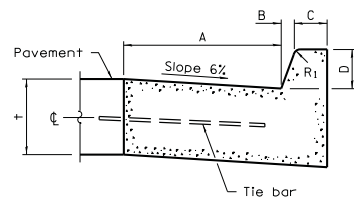

**BARRIER CURB**

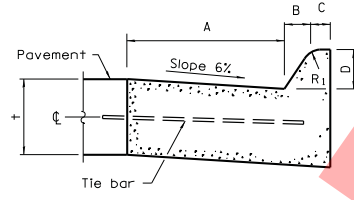

**MOUNTABLE CURB**

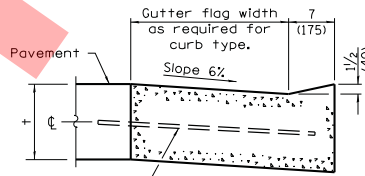

**DEPRESSED CURB (TYPICAL)**

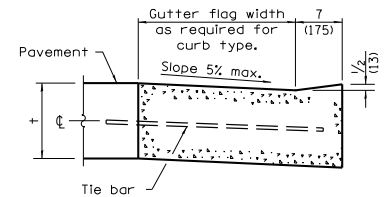

**DEPRESSED CURB ADJACENT TO CURB RAMP ACCESSIBLE TO THE DISABLED**

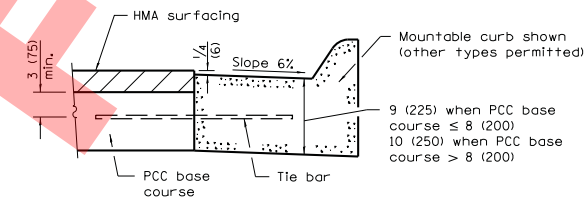

**ADJACENT TO PCC BASE COURSE WITH HMA SURFACING**

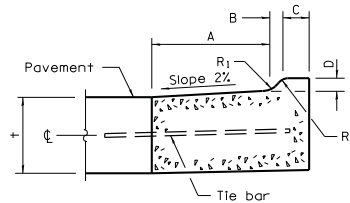

**M-2.06 (M-5.15) and M-2.12 (M-5.30)**

TABLE OF DIMENSIONS BARRIER CURB					
TYPE	A	B	C	D	R <sub>1</sub>
B-6.06*	6	1	6	6	1
(B-15.15)	(150)	(25)	(150)	(150)	(25)
B-6.12	12	1	6	6	1
(B-15.3)	(300)	(25)	(150)	(150)	(25)
B-6.18	18	1	6	6	1
(B-15.45)	(450)	(25)	(150)	(150)	(25)
B-6.24	24	1	6	6	1
(B-15.60)	(600)	(25)	(150)	(150)	(25)
B-9.12	12	2	5	9	1
(B-22.30)	(300)	(50)	(125)	(225)	(25)
B-9.18	18	2	5	9	1
(B-22.45)	(450)	(50)	(125)	(225)	(25)
B-9.24	24	2	5	9	1
(B-22.60)	(600)	(50)	(125)	(225)	(25)

\* For corner islands only.

TABLE OF DIMENSIONS MOUNTABLE CURB						
TYPE	A	B	C	D	R <sub>1</sub>	R <sub>2</sub>
M-2.06	6	2	4	2	3	2
(M-5.15)	(150)	(50)	(100)	(50)	(75)	(50)
M-2.12	12	2	4	2	3	2
(M-5.30)	(300)	(50)	(100)	(50)	(75)	(50)
M-4.06	6	4	3	4	3	NA
(M-10.15)	(150)	(100)	(75)	(100)	(75)	
M-4.12	12	4	3	4	3	NA
(M-10.30)	(300)	(100)	(75)	(100)	(75)	
M-4.18	18	4	3	4	3	NA
(M-10.45)	(450)	(100)	(75)	(100)	(75)	
M-4.24	24	4	3	4	3	NA
(M-10.60)	(600)	(100)	(75)	(100)	(75)	
M-6.06	6	6	2	6	2	NA
(M-15.15)	(150)	(150)	(50)	(150)	(50)	
M-6.12	12	6	2	6	2	NA
(M-15.30)	(300)	(150)	(50)	(150)	(50)	
M-6.18	18	6	2	6	2	NA
(M-15.45)	(450)	(150)	(50)	(150)	(50)	
M-6.24	24	6	2	6	2	NA
(M-15.60)	(600)	(150)	(50)	(150)	(50)	

Illinois Department of Transportation

PASSED January 1, 2015

Michael Beard  
ENGINEER OF POLICY AND PROCEDURES

APPROVED January 1, 2015

ENGINEER OF DESIGN AND ENVIRONMENT

15815

46-1-1 03/15

DATE	REVISIONS
1-1-15	Added B-6.06 (B-15.15) barrier curb and gutter to table (corner islands only).
1-1-13	Added general note regarding requirement for dowel bars.

**CONCRETE CURB TYPE B AND COMBINATION CONCRETE CURB AND GUTTER**

(Sheet 1 of 2)

**STANDARD 606001-06**

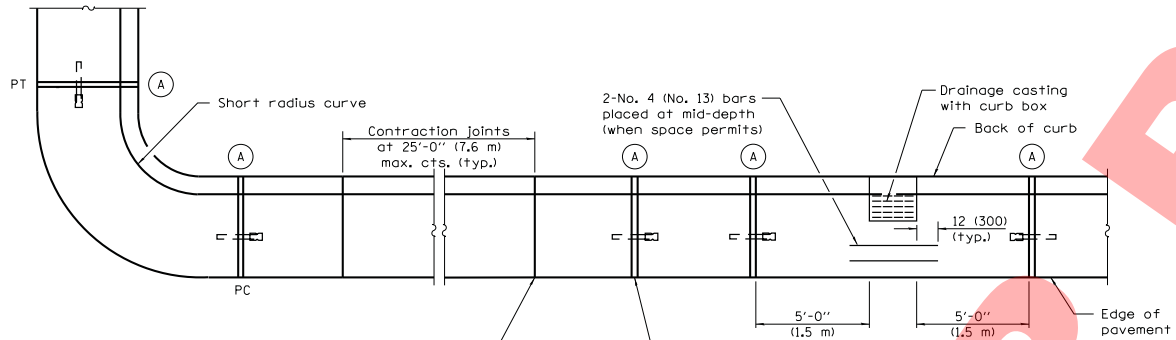

Undoweled contraction joint (typ.) construction options:

1. Form with 1/8 (3) thick steel template 2 (50) deep, and seal.
2. Saw 2 (50) deep at 4 to 24 hours, and seal.
3. Insert 3/4 (20) thick preformed joint filler full depth and width.

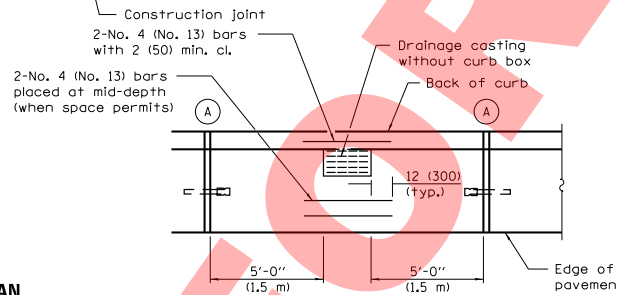

**PLAN**

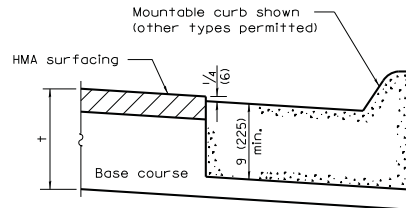

**ON DISTURBED SUBGRADE**

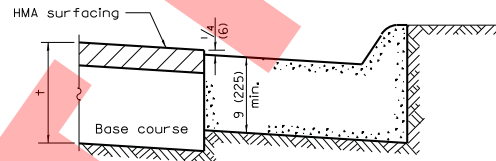

**ON UNDISTURBED SUBGRADE**

**ADJACENT TO FLEXIBLE PAVEMENT**

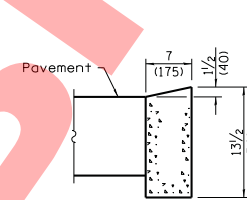

**DEPRESSED CURB**

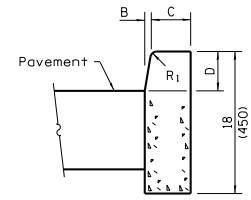

**BARRIER CURB**

**ADJACENT TO FLEXIBLE PAVEMENT**

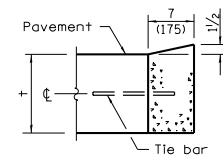

**DEPRESSED CURB**

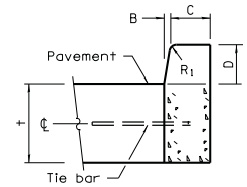

**BARRIER CURB**

**ADJACENT TO PCC PAVEMENT OR PCC BASE COURSE**

**CONCRETE CURB TYPE B**

**CONCRETE CURB TYPE B  
AND COMBINATION  
CONCRETE CURB AND GUTTER**  
(Sheet 2 of 2)

**STANDARD 606001-06**

Illinois Department of Transportation	
PASSED January 1, 2015	15315 46-1-1 03/15
ENGINEER OF POLICY AND PROCEDURES <i>Michael Beard</i>	
APPROVED January 1, 2015	
ENGINEER OF DESIGN AND ENVIRONMENT	

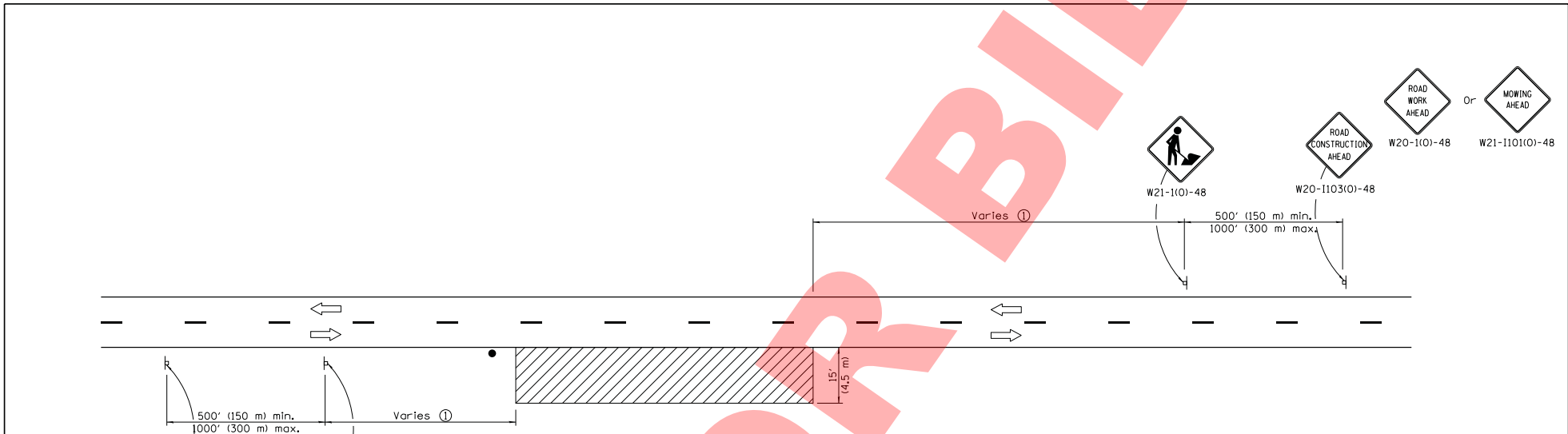

**TYPICAL APPLICATIONS**  
Shoulder work  
Utility operations

- For contract construction projects
- W20-110310-48
  - W21-1101-48
- For maintenance and utility projects
- W20-1101-48
  - W21-110110-48

**SYMBOLS**

- Work area
- Sign
- Flagger with traffic control sign when required

① Minimum distance is 200' (60 m). Maximum distance to be determined by the Engineer but should not exceed 1/2 the length required for one normal working day's operation, or 4 miles (6.4 km) whichever is less.

**GENERAL NOTES**

This Standard is used where at any time, any vehicle, equipment, workers or their activities require an intermittent or continuous moving operation on the shoulder, where the average speed is 1 mph (2 km/h) or less.

When the work operation does not exceed 60 minutes, traffic control may be according to Standard 701301.

All dimensions are in inches (millimeters) unless otherwise shown.

DATE	REVISIONS
1-1-14	Revised workers sign number to agree with current MUTCD.
1-1-13	Omitted text 'WORKERS' sign.

**OFF-ROAD MOVING OPERATIONS, 2L, 2W, DAY ONLY**

**STANDARD 701011-04**

Illinois Department of Transportation

APPROVED January 1, 2014  
ENGINEER OF SAFETY ENGINEERING

APPROVED January 1, 2014  
ENGINEER OF DESIGN AND ENVIRONMENT

1581658  
46-1-1 03/15/11

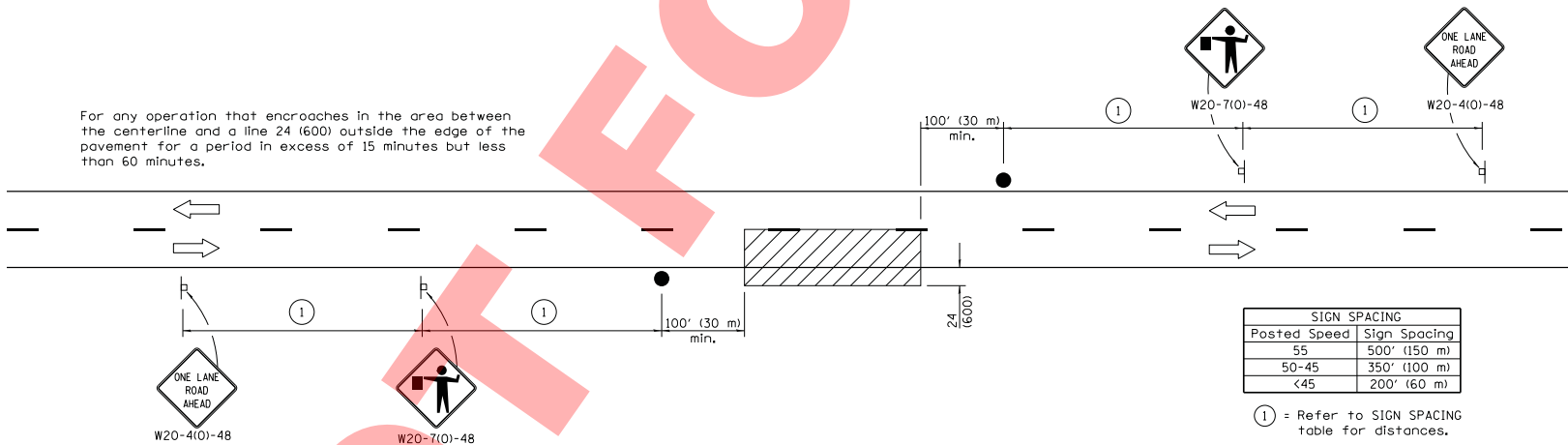
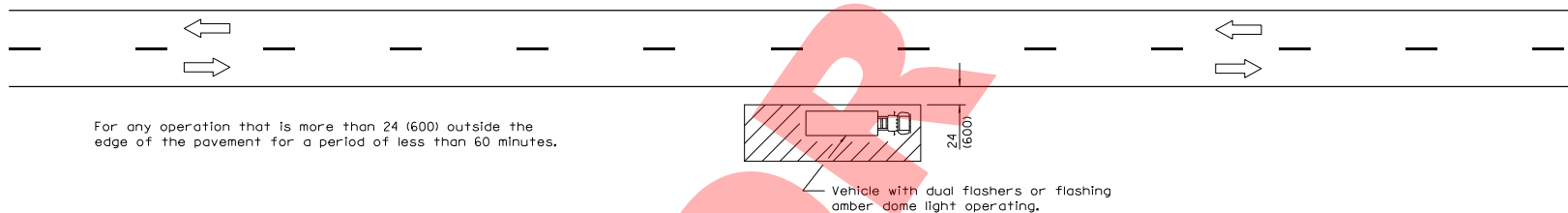
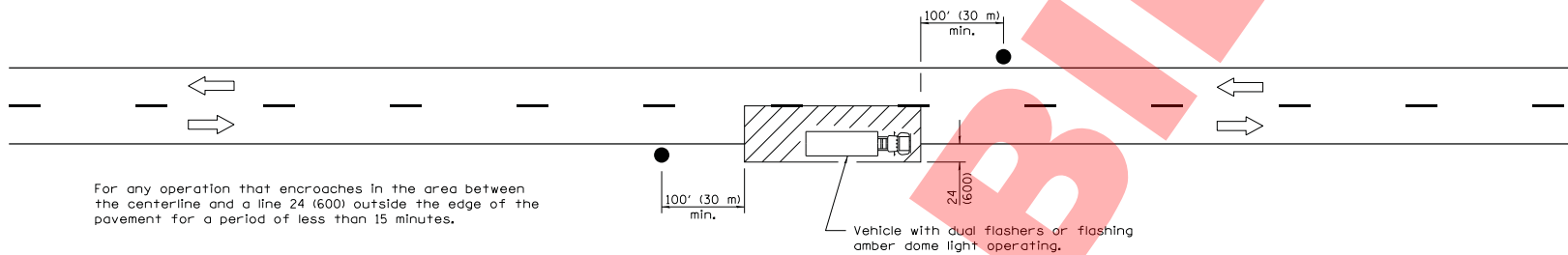

**TYPICAL APPLICATIONS**

- Marking patches
- Field survey
- String line
- Utility operations
- Cleaning up debris on pavement

**SYMBOLS**

- Work area
- Sign on portable or permanent support
- Flagger with traffic control sign

All dimensions are in inches (millimeters) unless otherwise shown.

Illinois Department of Transportation

APPROVED January 1, 2011  
ENGINEER OF SAFETY ENGINEERING

APPROVED January 1, 2011  
ENGINEER OF DESIGN AND ENVIRONMENT

158155  
46-1-1 03/05/11

DATE	REVISIONS
1-1-11	Revised flagger sign.
1-1-09	Switched units to English (metric).

**LANE CLOSURE, 2L, 2W, SHORT TIME OPERATIONS**

STANDARD 701301-04

NOT FOR BID

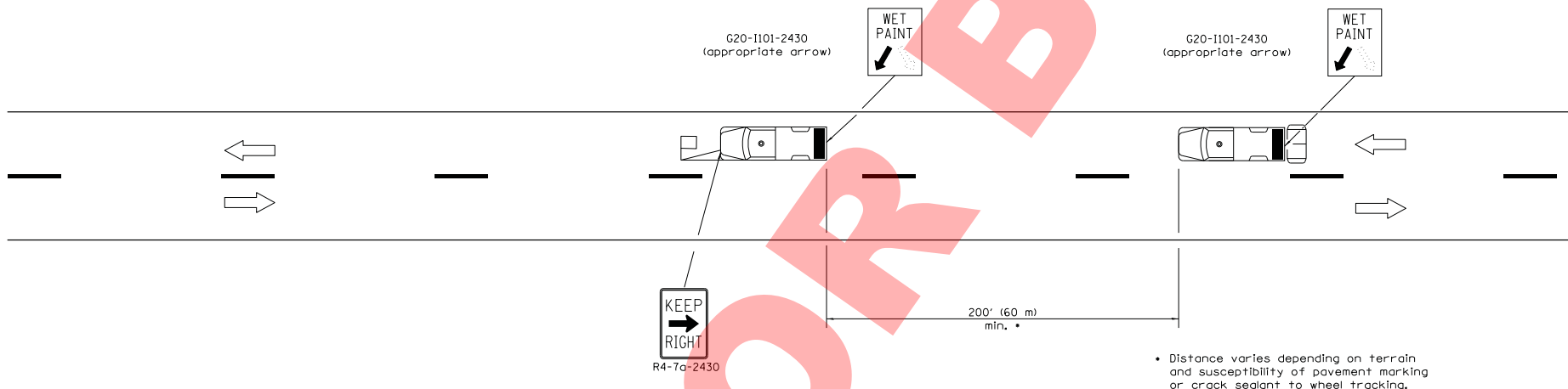

- TYPICAL APPLICATIONS**
- Landscaping work
  - Utility work
  - Pavement marking
  - Weed spraying
  - Roadmeter measurements
  - Debris cleanup
  - Crack pouring

- SYMBOLS**
- Arrow board (Hazard Mode only)
  - Truck with headlights, emergency flashers and flashing amber light. (visible from all directions)
  - 18x18 (450x450) min. orange flag (use when guide wheel is used)
  - Truck mounted attenuator

**GENERAL NOTES**

This Standard is used where any vehicle, equipment, workers or their activities will require a continuous moving operation where the average speed is greater than 3 mph (5 km/h).

For shoulder operations not encroaching on the pavement, use DETAIL A, Standard 701426.

All dimensions are in inches (millimeters) unless otherwise shown.

Illinois Department of Transportation

APPROVED January 1, 2009  
ENGINEER OF OPERATIONS

APPROVED January 1, 2009  
ENGINEER OF DESIGN AND ENVIRONMENT

ISSUED 1-1-197

DATE	REVISIONS
1-1-09	Switched units to English (metric). Omitted Pass With Care sign.
1-1-00	Elim. speed restrictions in Standard title.

**LANE CLOSURE 2L, 2W  
MOVING OPERATIONS-  
DAY ONLY**

**STANDARD 701311-03**

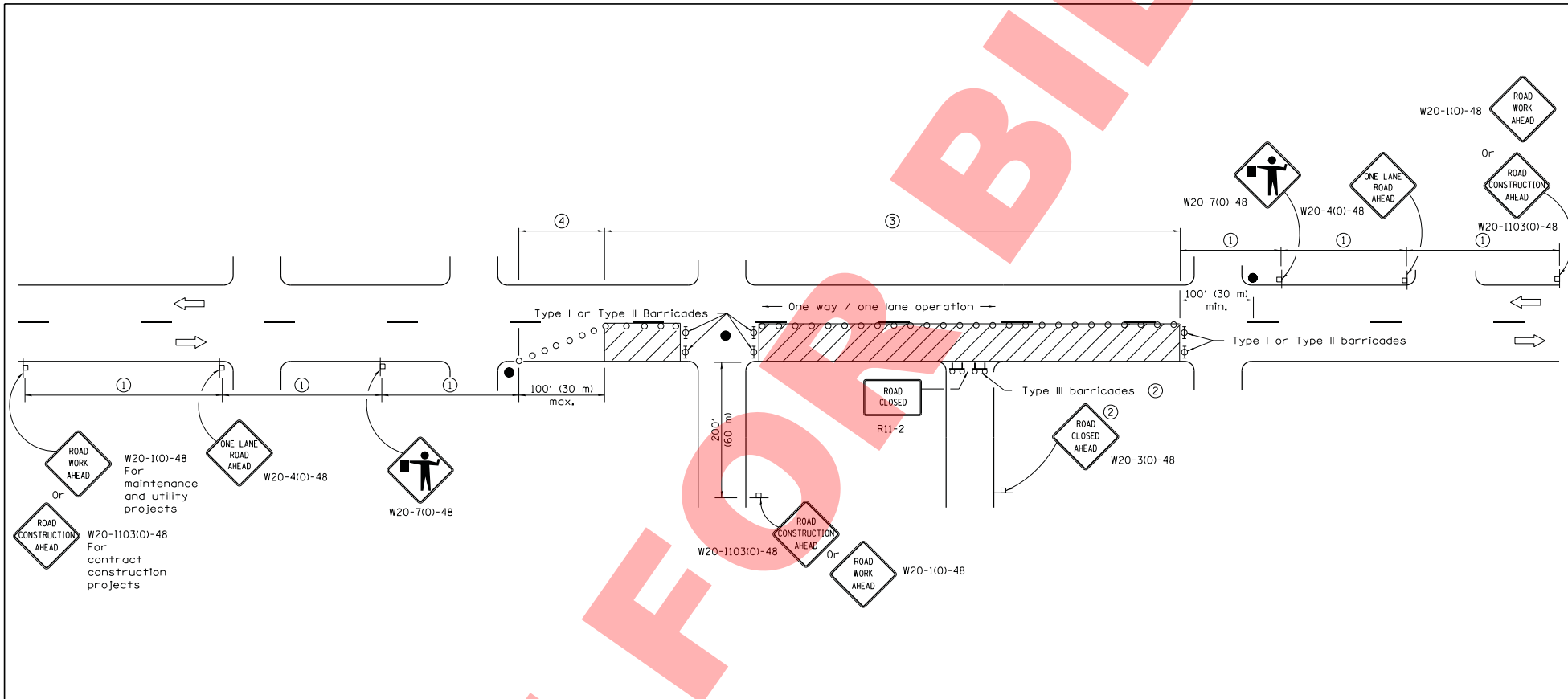

SIGN SPACING	
Posted Speed	Sign Spacing
55	500' (150 m)
50-45	350' (100 m)
<45	200' (60 m)

**SYMBOLS**

- Work area
- Cone, drum or barricade (not required for moving operations)
- Sign on portable or permanent support
- Flagger with traffic control sign
- Barricade or drum with flashing light
- Type III barricade with flashing lights

- ① Refer to SIGN SPACING TABLE for distances.
- ② For approved sideroad closures.
- ③ Cones at 25' (8 m) centers for 250' (75 m). Additional cones may be placed at 50' (15 m) centers. When drums or Type I or Type II barricades are used, the interval between devices may be doubled.
- ④ Cones, drums or barricades at 20' (6 m) centers.

**GENERAL NOTES**

This Standard is used where at any time, day or night, any vehicle, equipment, workers or their activities encroach on the pavement requiring the closure of one traffic lane in an urban area.

All dimensions are in inches (millimeters) unless otherwise shown.

Illinois Department of Transportation

APPROVED January 1, 2011  
  
 ENGINEER OF SAFETY ENGINEERING

APPROVED January 1, 2011  
  
 ENGINEER OF DESIGN AND ENVIRONMENT

15815  
 48-1-1 03/15/11

DATE	REVISIONS
1-1-11	Revised flagger sign.
1-1-09	Switched units to English (metric). Corrected sign No.'s.

**URBAN LANE CLOSURE,  
2L, 2W, UNDIVIDED**

**STANDARD 701501-06**

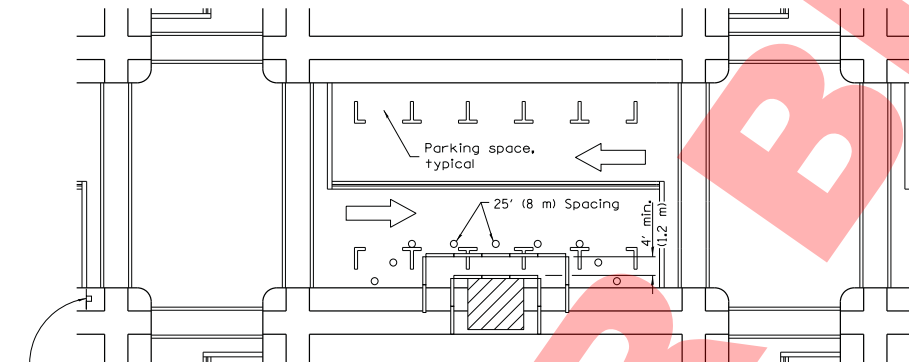







① ROAD CONSTRUCTION AHEAD  
W20-1103(O)-48 for contract construction projects

Or  
① ROAD WORK AHEAD  
W20-110-48 for maintenance and utility projects

**SIDEWALK DIVERSION**

① Omit whenever duplicated by road work traffic control.

**SYMBOLS**

-  Work area
-  Sign on portable or permanent support
-  Barricade or drum
-  Cone, drum or barricade
-  Type III barricade
-  Detectable pedestrian channelizing barricade

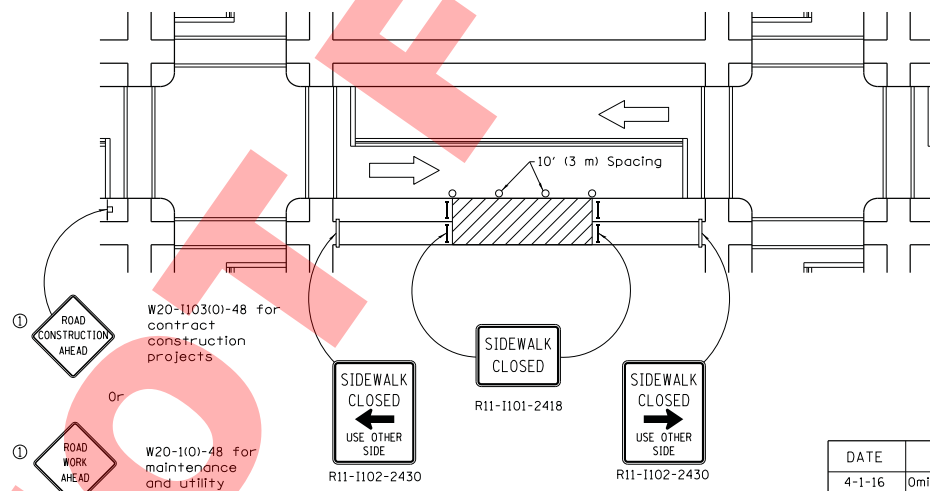

① ROAD CONSTRUCTION AHEAD  
W20-1103(O)-48 for contract construction projects

Or  
① ROAD WORK AHEAD  
W20-110-48 for maintenance and utility projects

SIDEWALK CLOSED  
R11-1102-2430  
USE OTHER SIDE

SIDEWALK CLOSED  
R11-1101-2418

SIDEWALK CLOSED  
R11-1102-2430  
USE OTHER SIDE

**SIDEWALK CLOSURE**

**GENERAL NOTES**

This Standard is used where, at any time, pedestrian traffic must be rerouted due to work being performed.

This Standard must be used in conjunction with other Traffic Control & Protection Standards when roadway traffic is affected.

Temporary facilities shall be detectable and accessible.

The temporary pedestrian facilities shall be provided on the same side of the closed facilities whenever possible.

The SIDEWALK CLOSED / USE OTHER SIDE sign shall be placed at the nearest crosswalk or intersection to each end of the closure. Where the closure occurs at a corner, the signs shall be erected on the corners across the street from the closure. The SIDEWALK CLOSED signs shall be used at the ends of the actual closures.

Type III barricades and R11-2-4830 signs shall be positioned as shown in "ROAD CLOSED TO ALL TRAFFIC" detail on Standard 701901.

All dimensions are in inches (millimeters) unless otherwise shown.

DATE	REVISIONS
4-1-16	Omitted orange safety fence from standard as this is covered in the std. spec.
1-1-12	Added SIDEWALK DIVERSION.
	Modified appearance of plan views. Renamed Std.

**SIDEWALK, CORNER OR CROSSWALK CLOSURE**

(Sheet 1 of 2)

**STANDARD 701801-06**

Illinois Department of Transportation

APPROVER: *[Signature]* April 1, 2016  
ENGINEER OF SAFETY ENGINEERING

APPROVED: *[Signature]* April 1, 2016  
ENGINEER OF DESIGN AND ENVIRONMENT

ISSUES: 46-1-1 03/15/16

NOT FOR BIDDING

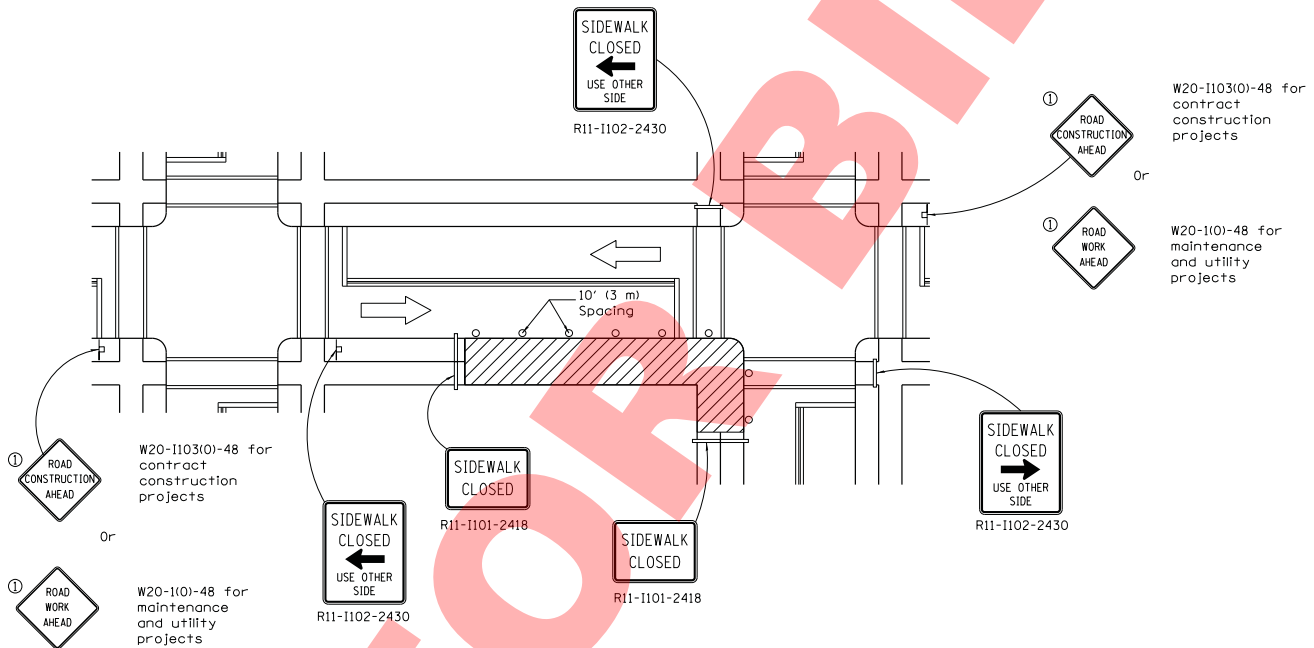

**CORNER CLOSURE**

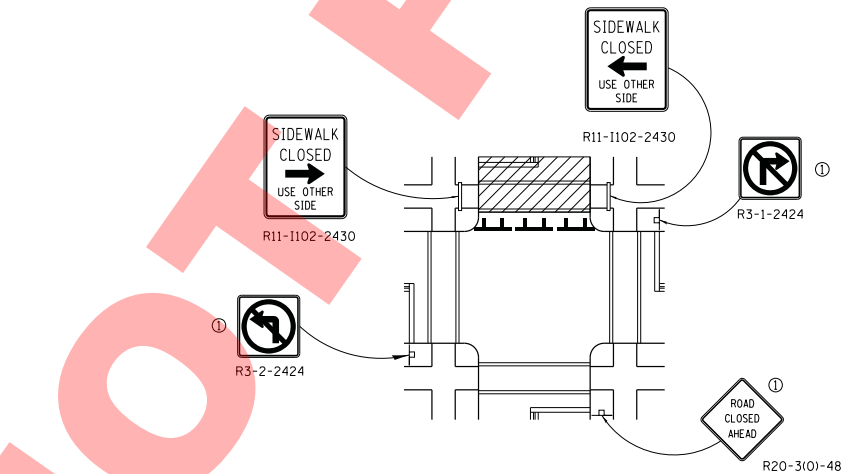

**CROSSWALK CLOSURE**

**SIDEWALK, CORNER OR CROSSWALK CLOSURE**

(Sheet 2 of 2)

STANDARD 701801-06

Illinois Department of Transportation	
APPROVER	April 1, 2016
ENGINEER OF SAFETY ENGINEERING	<i>[Signature]</i>
APPROVED	April 1, 2016
ENGINEER OF DESIGN AND ENVIRONMENT	<i>[Signature]</i>

ISSUED  
48-1-1

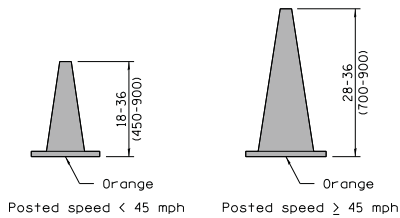

**CONE FOR DAYTIME**

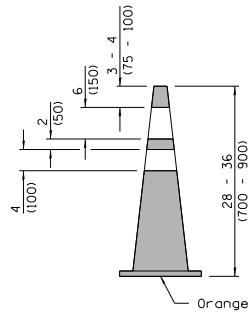

**REFLECTORIZED CONE FOR NIGHTTIME**

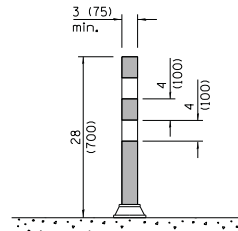

**TUBULAR MARKER**

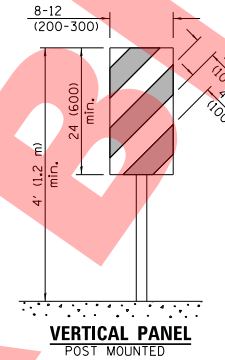

**VERTICAL PANEL POST MOUNTED**

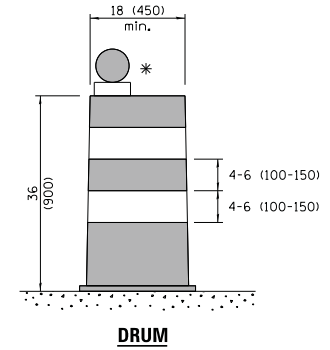

**DRUM**

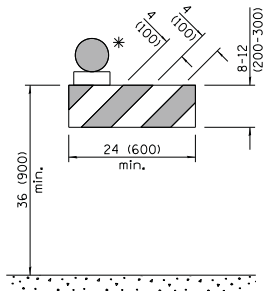

**TYPE I BARRICADE**

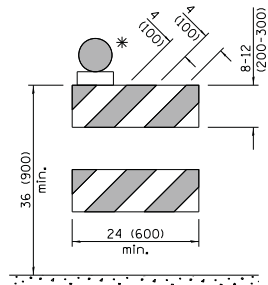

**TYPE II BARRICADE**

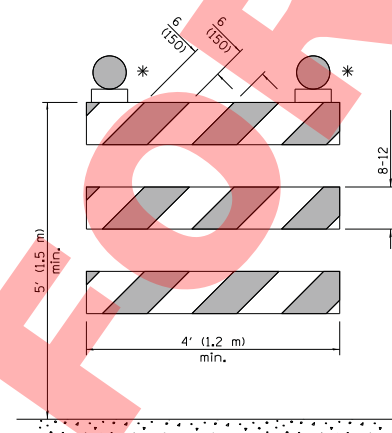

**TYPE III BARRICADE**

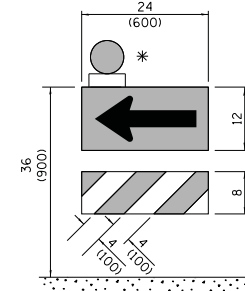

**DIRECTION INDICATOR BARRICADE**

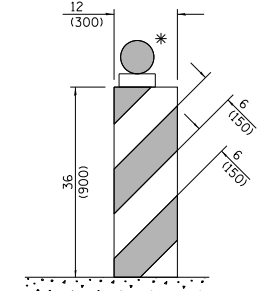

**VERTICAL BARRICADE**

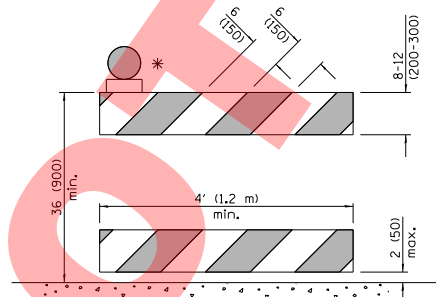

**DETECTABLE PEDESTRIAN CHANNELIZING BARRICADE**

\* Warning lights (if required)

**GENERAL NOTES**

All heights shown shall be measured above the pavement surface.

All dimensions are in inches (millimeters) unless otherwise shown.

DATE	REVISIONS
1-1-17	Changed FLEXIBLE DELINEATOR to TUBULAR MARKER.
4-1-16	Add dim's to barricades, Rev. note for post mnt. signs, Rev. cone dtls, Add W12-1103.

**TRAFFIC CONTROL DEVICES**

(Sheet 1 of 3)

**STANDARD 701901-06**

Illinois Department of Transportation

APPROVED January 1, 2017  
ENGINEER OF OPERATIONS

APPROVED January 1, 2017  
ENGINEER OF DESIGN AND ENVIRONMENT

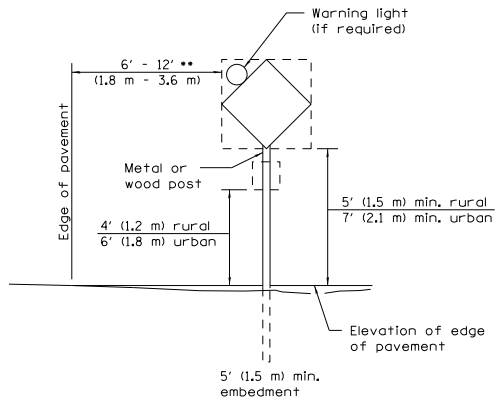

**POST MOUNTED SIGNS**

\*\* When curb or paved shoulder are present this dimension shall be 24 (600) to the face of curb or 6' (1.8 m) to the outside edge of the paved shoulder.

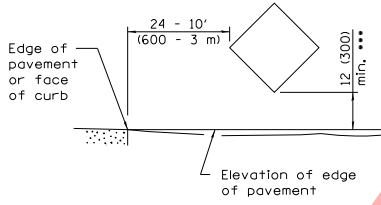

**SIGNS ON TEMPORARY SUPPORTS**

\*\*\* When work operations exceed four days, this dimension shall be 5' (1.5 m) min. If located behind other devices, the height shall be sufficient to be seen completely above the devices.

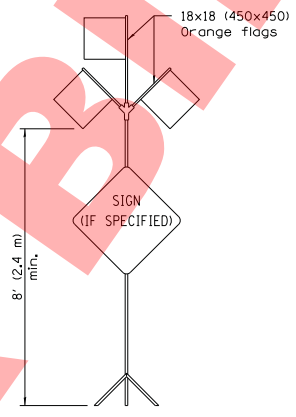

**HIGH LEVEL WARNING DEVICE**

ROAD CONSTRUCTION NEXT X MILES

END CONSTRUCTION

G20-1104(O)-6036

G20-1105(O)-6024

This signing is required for all projects 2 miles (3200 m) or more in length.

ROAD CONSTRUCTION NEXT X MILES sign shall be placed 500' (150 m) in advance of project limits.

END CONSTRUCTION sign shall be erected at the end of the job unless another job is within 2 miles (3200 m).

Dual sign displays shall be utilized on multi-lane highways.

**WORK LIMIT SIGNING**

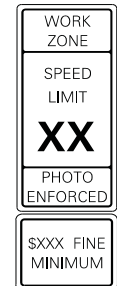

W21-II5(O)-3618

R2-1-3648

R10-1108p-3618 \*\*\*\*

R2-1106p-3618

Sign assembly as shown on Standards or as allowed by District Operations.

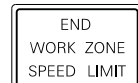

G20-1103(O)-6036

This sign shall be used when the above sign assembly is used.

**HIGHWAY CONSTRUCTION SPEED ZONE SIGNS**

\*\*\*\* R10-1108p shall only be used along roadways under the jurisdiction of the State.

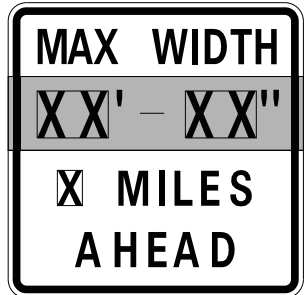

W12-1103-4848

**WIDTH RESTRICTION SIGN**

XX'-XX" width and X miles are variable.

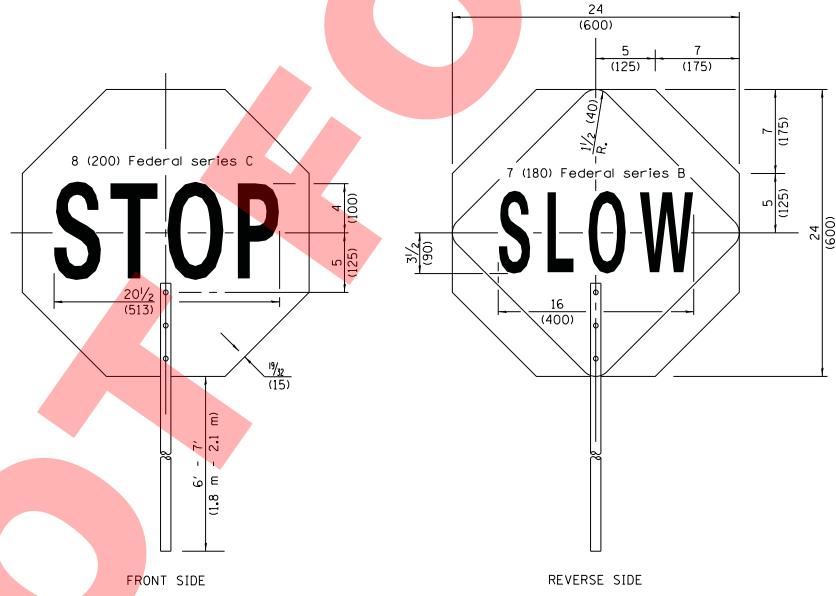

**FLAGGER TRAFFIC CONTROL SIGN**

Illinois Department of Transportation

APPROVED January 1, 2017  
*Jim Allen*  
 ENGINEER OF OPERATIONS

APPROVED January 1, 2017  
*Thomas M. Bels*  
 ENGINEER OF DESIGN AND ENVIRONMENT

158585  
 48-1-1  
 249

**TRAFFIC CONTROL DEVICES**

(Sheet 2 of 3)

STANDARD 701901-06

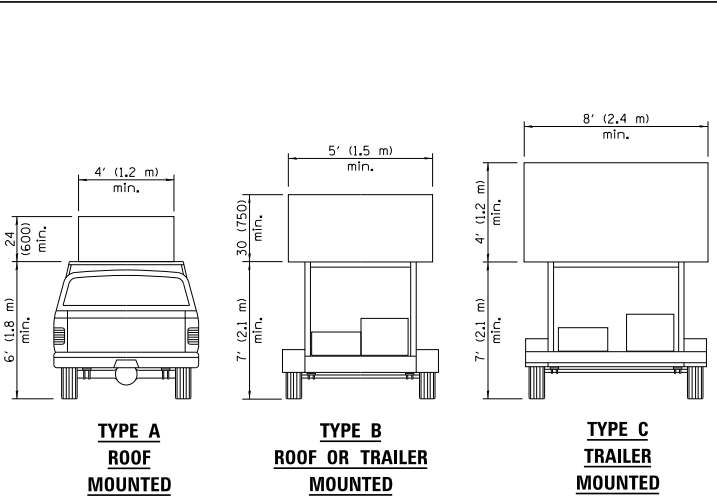

**ARROW BOARDS**

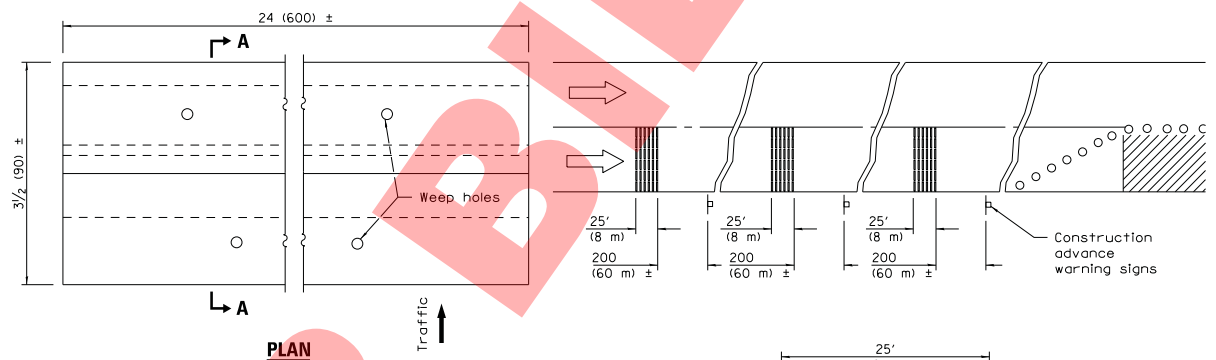

**PLAN**

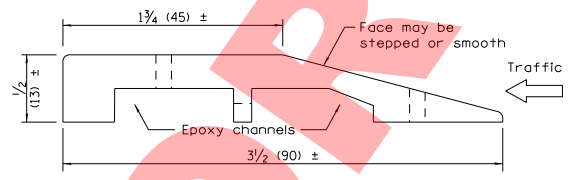

**SECTION A-A**

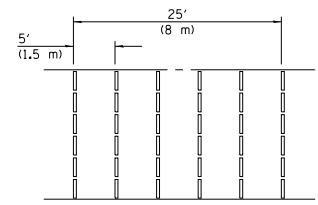

**TYPICAL INSTALLATION**

**TEMPORARY RUMBLE STRIPS**

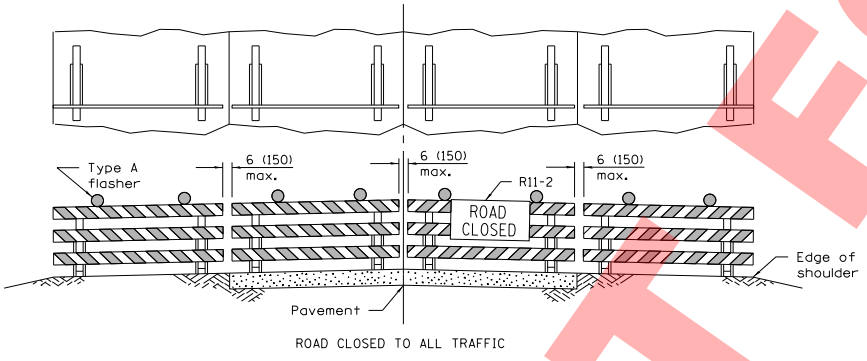

Reflectorized striping may be omitted on the back side of the barricades. If a Type III barricade with an attached sign panel which meets NCHRP 350 is not available, the sign may be mounted on an NCHRP 350 temporary sign support directly in front of the barricade.

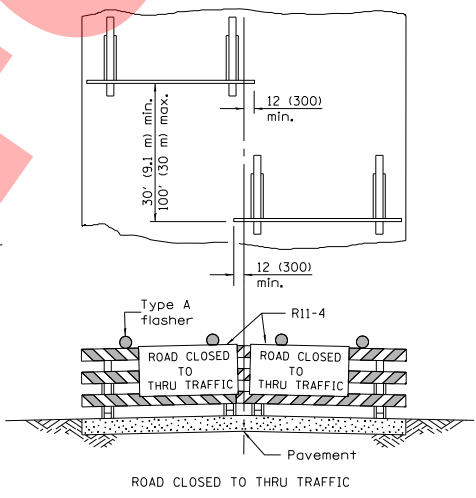

Reflectorized striping shall appear on both sides of the barricades. If a Type III barricade with an attached sign panel which meets NCHRP 350 is not available, the signs may be mounted on NCHRP 350 temporary sign supports directly in front of the barricade.

**TYPICAL APPLICATIONS OF TYPE III BARRICADES CLOSING A ROAD**

Illinois Department of Transportation

APPROVED January 1, 2017

ENGINEER OF OPERATIONS

APPROVED January 1, 2017

ENGINEER OF DESIGN AND ENVIRONMENT

153155

03/15/17

24-1-1

**TRAFFIC CONTROL DEVICES**

STANDARD 701901-06

(Sheet 3 of 3)

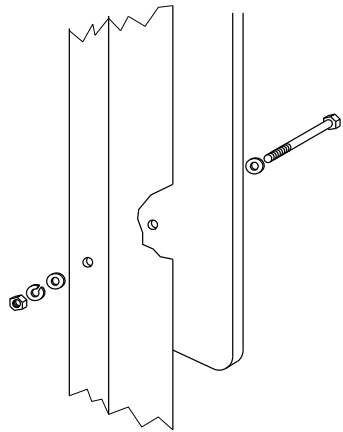

Sign panel 36 (900) wide or less

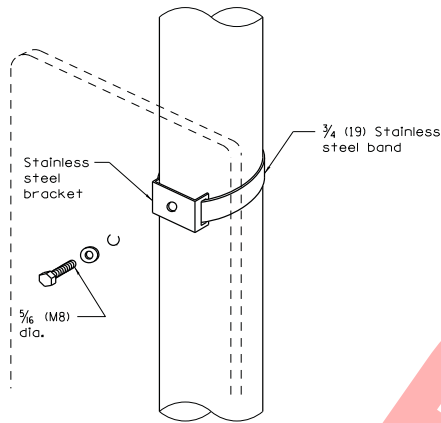

Sign panel 36 (900) wide or less

Section modulus (minimum)	Axis A	Axis B
Steel	0.050 in. <sup>3</sup> (819 mm <sup>3</sup> )	0.105 in. <sup>3</sup> (1720 mm <sup>3</sup> )
Aluminum	0.150 in. <sup>3</sup> (2458 mm <sup>3</sup> )	0.315 in. <sup>3</sup> (5162 mm <sup>3</sup> )

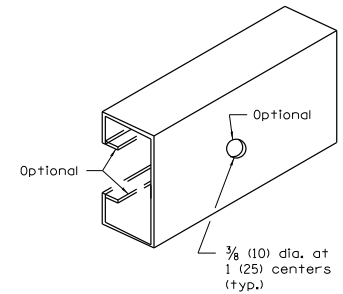
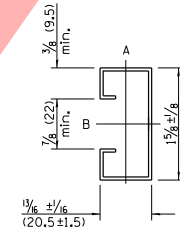

**SUPPORTING CHANNEL DETAILS**

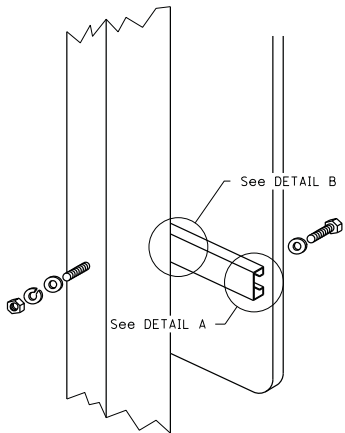

Sign panel over 36 (900) wide

**WOOD OR TELESCOPING STEEL POSTS**

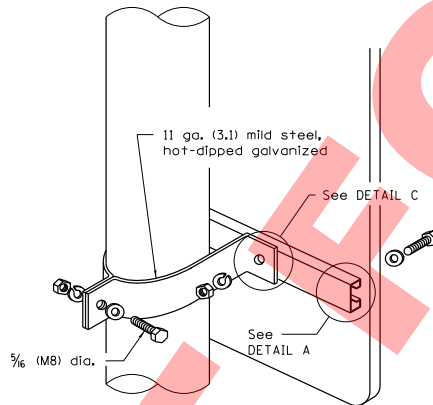

Sign panel over 36 (900) wide

**LIGHT OR SIGNAL STANDARDS**

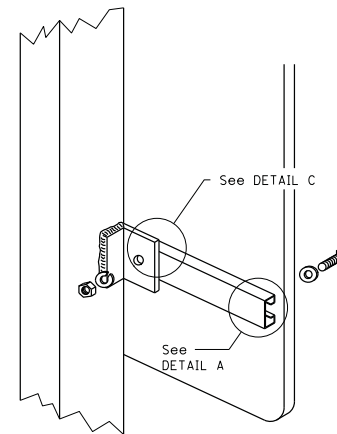

**BREAKAWAY STEEL TUBING POSTS**  
(All sign panel sizes)

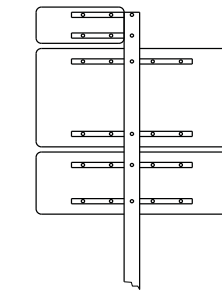

**ROUTE MARKER ASSEMBLY**

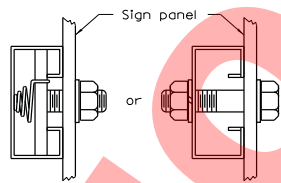

**DETAIL A**

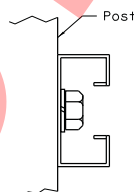

**DETAIL B**

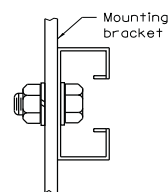

**DETAIL C**

All dimensions are in inches (millimeters) unless otherwise shown.

DATE	REVISIONS
1-1-09	Switched units to English (metric).
1-1-97	Renum. Standard 2319-6.

**SIGN PANEL MOUNTING DETAILS**

**STANDARD 720001-01**

Illinois Department of Transportation

APPROVED January 1, 2009

ENGINEER OF OPERATIONS

APPROVED January 1, 2009

ENGINEER OF DESIGN AND ENVIRONMENT

158555

46-1-1

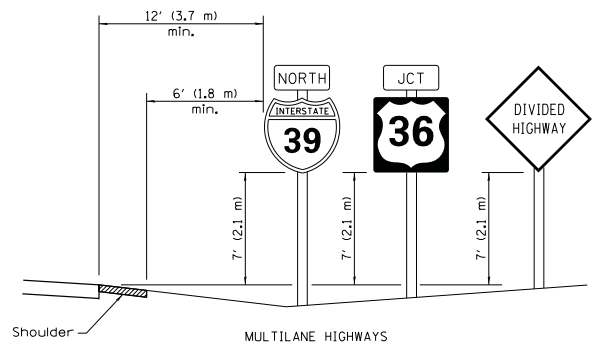

MULTILANE HIGHWAYS

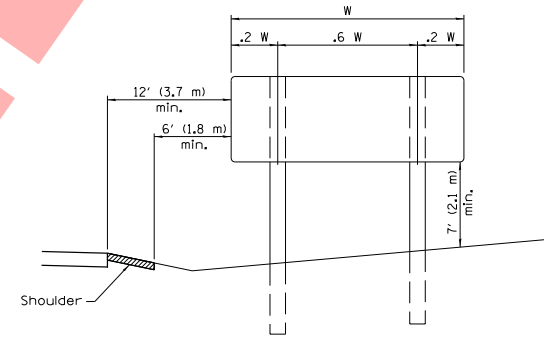
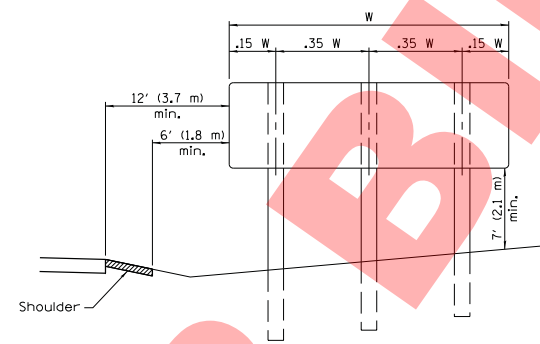

POST SPACING FOR NON-FREEWAY SIGN PANELS

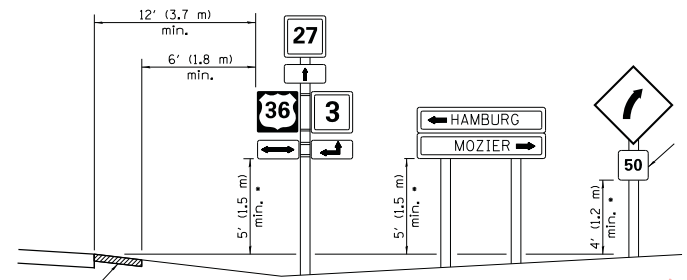

• In any area where parking is likely to occur or where there are obstructions to view or where signs are located over sidewalks, the height shall be at least 7' (2.1 m).

TWO LANE RURAL HIGHWAYS

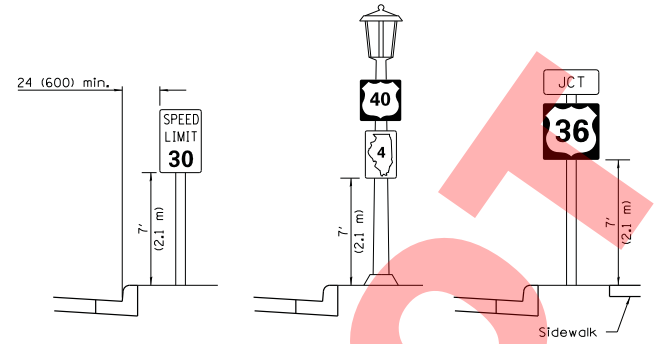

URBAN LOCATIONS

**TYPICAL INSTALLATIONS**

Signs in any area shall be erected to a uniform height above the edge of the pavement.

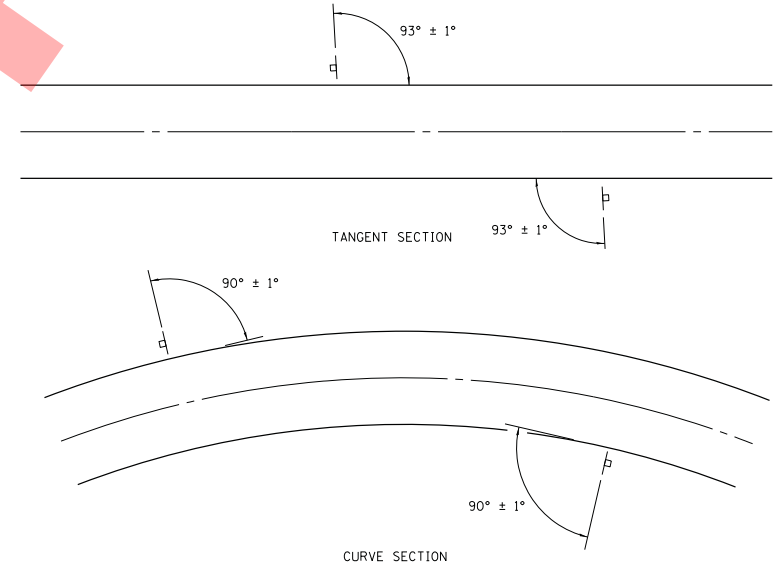

GROUND MOUNT SIGN POSITIONING

All dimensions are in inches (millimeters) unless otherwise shown.

Illinois Department of Transportation

APPROVED January 1, 2014  
 ENGINEER OF OPERATIONS  
 APPROVED January 1, 2014  
 ENGINEER OF DESIGN AND ENVIRONMENT

1585  
 46-1-1 03/85

DATE	REVISIONS
1-1-14	Added shoulders and slopes. Changed sign distances from roadway and shoulder.
1-1-12	Rev. sign elev. for multilane hwy's. Revised sign elev. and dist. to curb for rural loc.

**SIGN PANEL  
ERECTION DETAILS**

STANDARD 720006-04

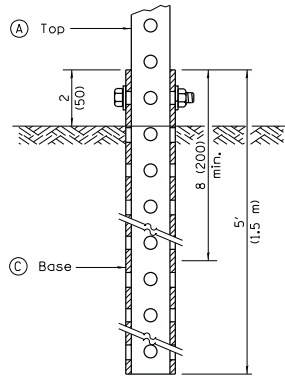

**GROUND MOUNT DETAIL**

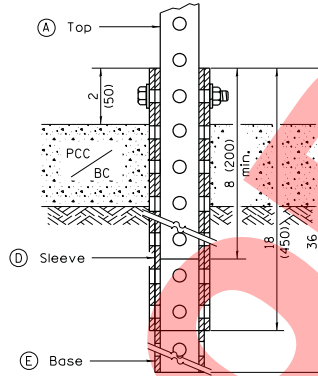

**PAVEMENT MOUNT DETAIL**

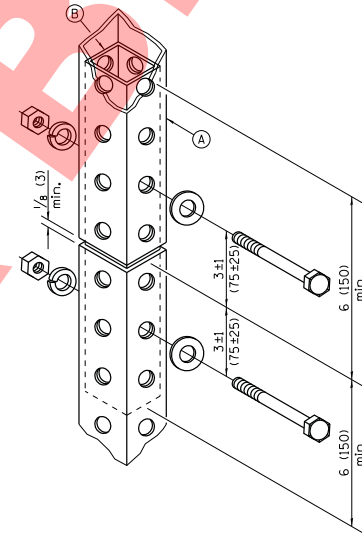

**SPLICE DETAIL**

A	2 x 2 x var. (51 x 51 var.)
B	1 3/4 x 1 3/4 x 12 (44 x 44 x 300)
C	2 1/4 x 2 1/4 x 60 (57 x 57 x 1500)
D	2 1/2 x 2 1/2 x 18 (64 x 64 x 450)
E	2 1/4 x 2 1/4 x 36 (57 x 57 x 900)

**GENERAL NOTES**

All bolts 3/8 (M10) hex head zinc or cadmium plated.

All dimensions are in inches (millimeters) unless otherwise shown.

DATE	REVISIONS
1-1-09	Switched units to English (metric).
1-1-07	New Standard. Used to be part of Standard 720006.

**TELESCOPING STEEL SIGN SUPPORT**

**STANDARD 728001-01**

Illinois Department of Transportation	
APPROVED <u>January 1, 2009</u>  ENGINEER OF OPERATIONS	158353 JO-1-1 03/ISS/1
APPROVED <u>January 1, 2009</u>  ENGINEER OF DESIGN AND ENVIRONMENT	

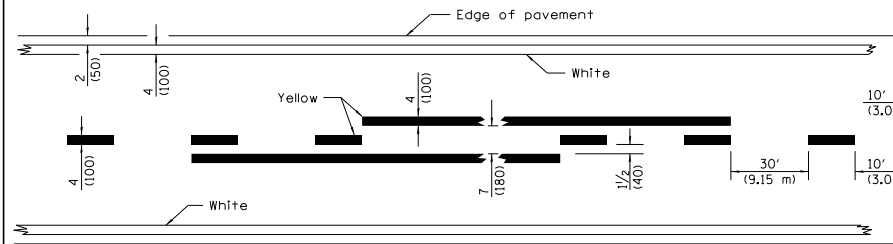

**2 LANE**

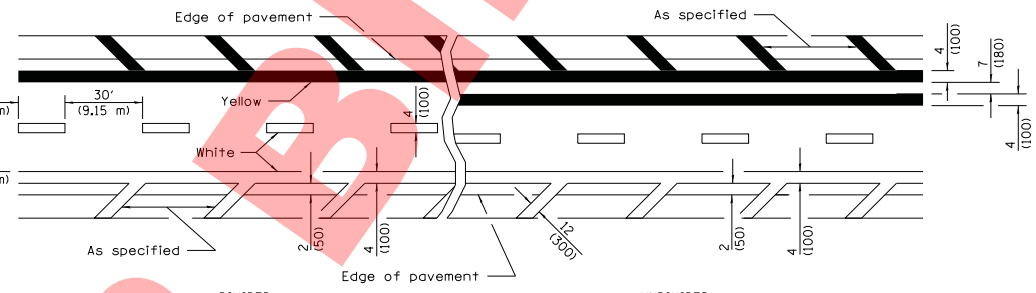

**MULTI LANE**

**LANE AND EDGE LINES**

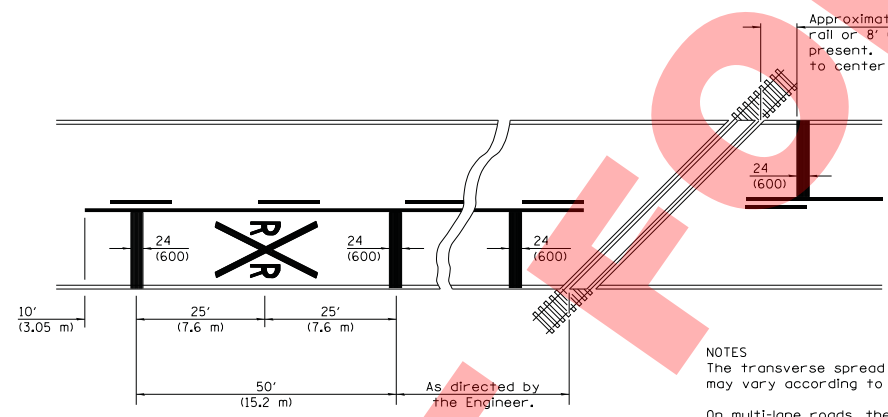

Approximately 15' (4.5 m) from nearest rail or 8' (2.4 m) back from gate, if present. Stop line placed perpendicular to center line.

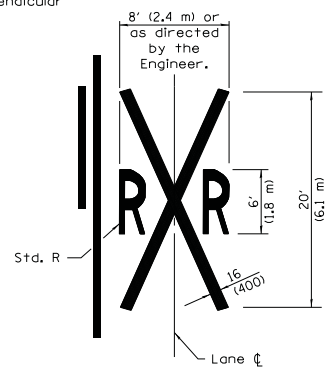

**NOTES**

The transverse spread of the "X" may vary according to lane width.

On multi-lane roads, the stop lines shall extend across all approach lanes and separate RXR symbols shall be placed adjacent to each other in each lane.

When the pavement marking symbol is used, a portion of the symbol should be located directly adjacent to the Advance Warning Sign (W10-1) as placed by Table 2C-4, Condition B of the MUTCD.

**PAVEMENT MARKINGS AT RAILROAD-HIGHWAY GRADE CROSSING**

All dimensions are in inches (millimeters) unless otherwise shown.

Illinois Department of Transportation

APPROVED January 1, 2015  
ENGINEER OF OPERATIONS

APPROVED January 1, 2015  
ENGINEER OF DESIGN AND ENVIRONMENT

1581555

46-1-1

DATE	REVISIONS
1-1-15	Added symbols. Revised bike symbol. Revised note for stop line at RR crossing.
1-1-14	Added bike symbol. Renamed 'LANE DROP ARROW' detail to 'LANE-REDUCTION ARROW'.

**TYPICAL PAVEMENT MARKINGS**

**STANDARD 780001-05**

(Sheet 1 of 3)

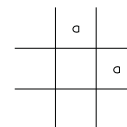
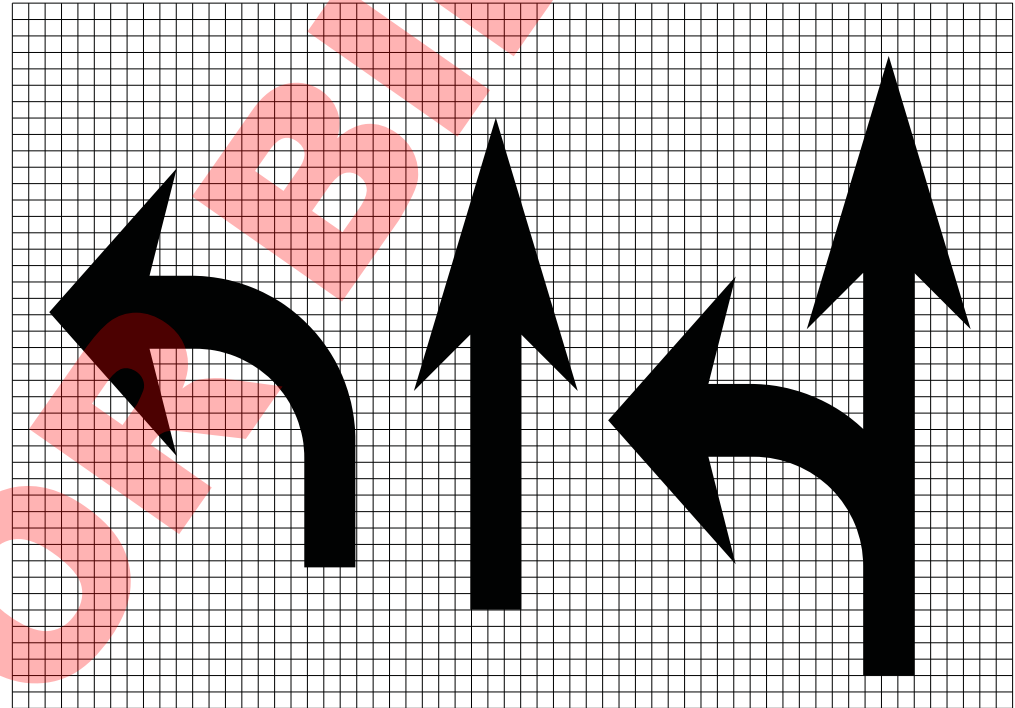
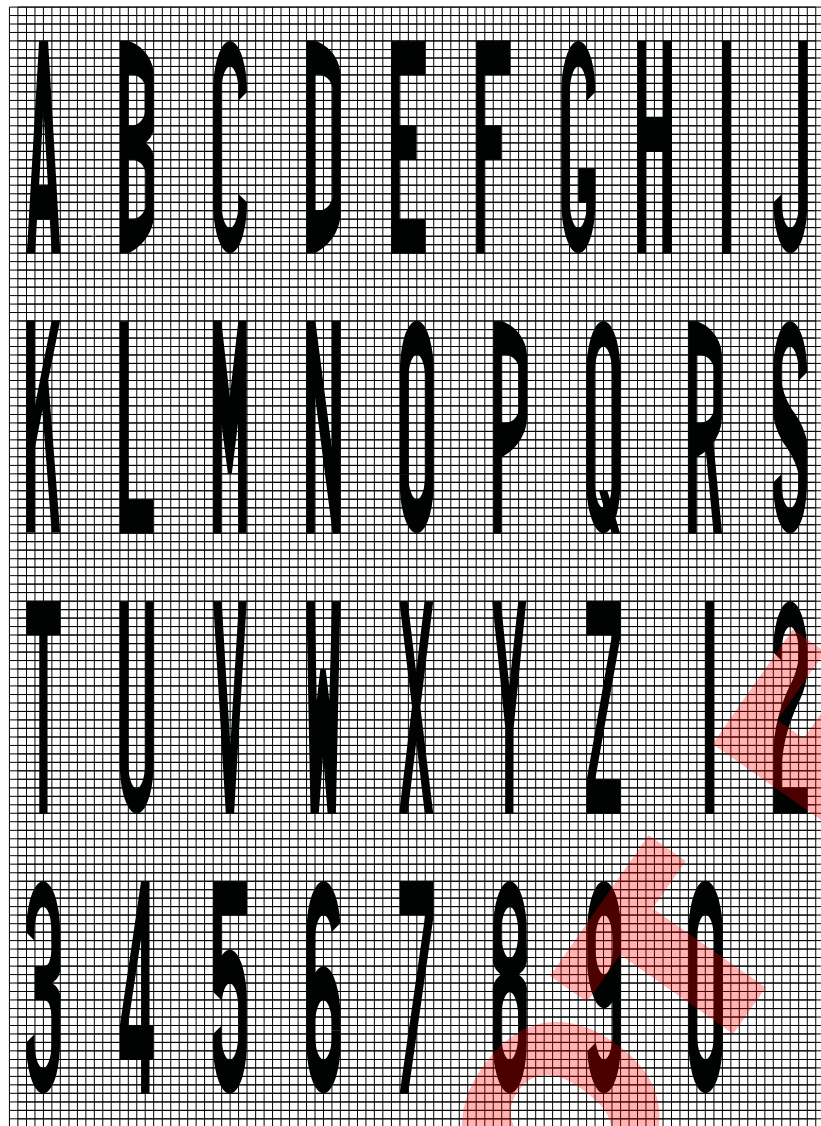

Legend Height	Arrow Size	a
6' (1.8 m)	Small	2.9 (74)
8' (2.4 m)	Large	3.8 (96)

The space between adjacent letters or numerals should be approximately 3 (75) for 6' (1.8 m) legend and 4 (100) for 8' (2.4 m) legend.

**LETTER AND ARROW GRID SCALE**

Illinois Department of Transportation

APPROVED January 1, 2015

ENGINEER OF OPERATIONS

APPROVED January 1, 2015

ENGINEER OF DESIGN AND ENVIRONMENT

ISSUED 48-1-1

**TYPICAL PAVEMENT MARKINGS**

(Sheet 2 of 3)

**STANDARD 780001-05**

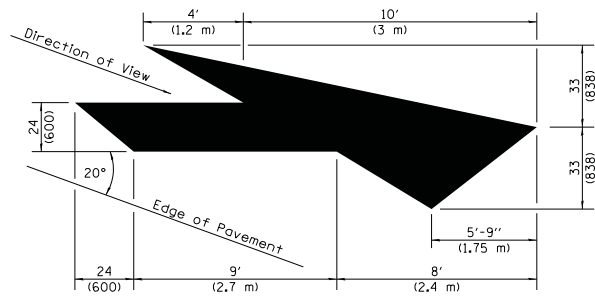

**LANE-REDUCTION ARROW**

Right lane-reduction arrow shown.  
Use mirror image for left lane.

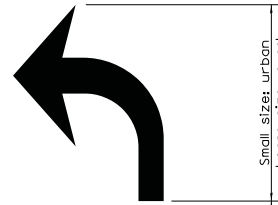

20' (6 m): urban  
50' (15 m): rural  
(Between arrow  
and word or  
between words)

**ONLY**

**WORD AND ARROW LAYOUT**

6" (1.8 m): urban  
8" (2.4 m): rural

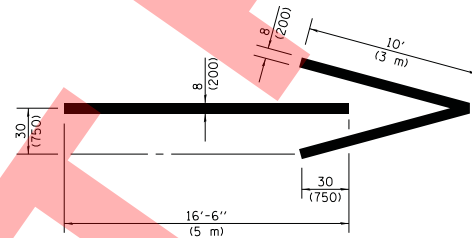

**WRONG WAY ARROW**

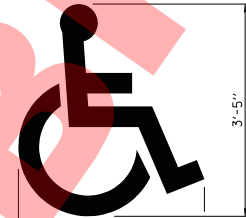

**INTERNATIONAL  
SYMBOL OF  
ACCESSIBILITY**

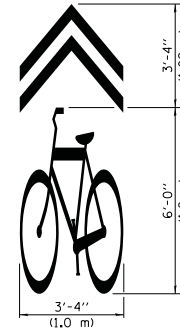

**SHARED LANE  
SYMBOL**

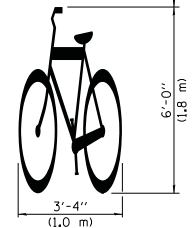
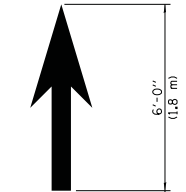

**BIKE SYMBOL**  
(Arrow is optional).

Illinois Department of Transportation	
APPROVED January 1, 2015  ENGINEER OF OPERATIONS	158155
APPROVED January 1, 2015  ENGINEER OF DESIGN AND ENVIRONMENT	46-1-1 03/15

**TYPICAL PAVEMENT  
MARKINGS**

(Sheet 3 of 3)

**STANDARD 780001-05**

APPENDIX 3  
AMENDING THE REQUIREMENTS OF BIDDERS FOR CONSTRUCTION PROJECTS  
IRMA CONTRACTUAL INSURANCE GUIDELINES

NOT FOR BID

**AN ORDINANCE OF THE VILLAGE OF VILLA PARK, DUPAGE COUNTY, ILLINOIS AMENDING THE REQUIREMENTS OF BIDDERS FOR CONSTRUCTION PROJECTS**

**WHEREAS**, the Village of Villa Park (the “*Village*”) is a duly organized and validly existing non home-rule municipality created in accordance with the Constitution of the State of Illinois of 1970 and the laws of the State; and,

**WHEREAS**, section 8-9-1 of the Illinois Municipal Code (65 ILCS 5/8-9-2) allows the Village to require competitive bidding after advertising for bids in the manner prescribed by ordinance; and,

**WHEREAS**, the President and Board of Trustees desire to adopt purchasing procedures to provide for additional requirements of bidders for construction projects to have active apprenticeship and training programs approved and registered with the United States Department of Labor’s Bureau of Apprenticeship and Training and to have bidders show three similar projects they constructed within the last five years.

**NOW, THEREFORE, BE IT ORDAINED** by the President and Board of Trustees of the Village of Villa Park, DuPage County, Illinois, as follows:

**Section 1.** That Section 2-219 of the Villa Park Municipal Code, as amended, be and is hereby amended by placing the existing text as subsection A. and adding a new subsection B. to read as follows:

“B. A responsible bidder for the construction of public works projects shall meet and submit evidence of compliance with the following requirements:

- (1) All applicable laws prerequisite to doing business in the State of Illinois,
- (2) A federal employer tax identification number or social security number,
- (3) Provision of Section 2000(e) of Chapter 21, Title 42 of the United States Code and Federal Executive Order No. 11246 as amended by Executive Order No. 11375 (known as the Equal Opportunity Employer provisions),
- (4) Certificates of insurance indicating the following coverage’s: general liability, worker’s compensation, completed operations, automobile, hazardous occupation and product liability
- (5) Compliance with all provisions of the Illinois Prevailing Wage Act, including wages, medical and hospitalization insurance and retirement for those trades covered in the Act,
- (6) The bidder and all bidder’s sub-contractors must participate in active apprenticeship and training programs approved and registered with the United States Department of Labor’s Bureau of Apprenticeship and Training for each of the trades of work contemplated under the proposed contract,
- (7) All contractors and sub-contractors are required to file certified payrolls as specified in Illinois Public Act 94-0515, and follow all provisions of the Employee Classification Act (820 ILCS 185/1 et seq.), and

(8) All bidders must provide three (3) projects of a similar nature constructed in the immediate past five (5) years with the name, address and telephone number of the contact person having knowledge of the project along with three (3) references (name, address, and telephone number) with knowledge of the integrity and business practices of the bidder.”

**Section 2.** This Ordinance shall be in full force and effect upon its passage, approval, and publication as provided by law.

Passed this 11 day of February, 2013.

AYES: ALL

NAYS: Aiello Bulthuis

ABSENT: \_\_\_\_\_

Approved this 11 day of February, 2013.

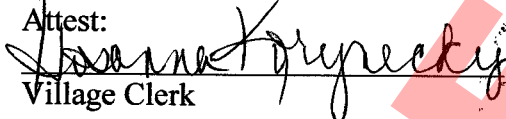

Village President

Attest:  
  
Village Clerk

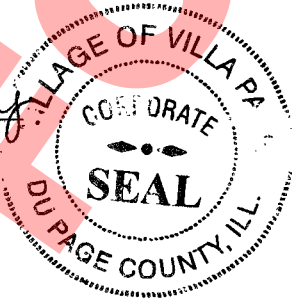

Published in pamphlet form:

2-11, 2013

# IRMA

## CONTRACTUAL INSURANCE GUIDELINES

### I. INSURANCE REQUIREMENTS

Contractor shall procure and maintain, for the duration of the contract, insurance against claims for injuries to persons or damages to property, which may arise from or in connection with the performance of the work hereunder by the Contractor, his agents, representatives, employees or subcontractors.

#### MINIMUM SCOPE OF INSURANCE

Coverage shall be at least as broad as:

- A. Insurance Services Office Commercial General Liability occurrence form CG 0001 with the member named as additional insured, on a form at least as broad as the attached sample endorsement including ISO Additional Insured Endorsement CG 2010 (Exhibit A), CG 2026 (Exhibit B).

**CG2037 - Completed Operations – (Exhibit C)**  
**Required if box is checked**  ; and

- B. Owners and Contractors Protective Liability (OCP) policy with the member as insured

**Required if box is checked**  ; and

- C. Insurance Service Office Business Auto Liability coverage form number CA 0001, Symbol 01 "Any Auto."

- D. Workers' Compensation as required by the Workers' Compensation Act of the State of Illinois and Employers' Liability insurance.

**Coverage required for employee exposure to lead, if box is checked**

- E. Builder Risk Property Coverage with member as loss payee

**Required if box is checked** .

- F. Environmental Impairment/Pollution Liability Coverage for pollution incidents as a result of a claim for bodily injury, property damage or remediation costs from an incident at, on or migrating beyond the contracted work site. Coverage shall be extended to Non-Owned Disposal sites resulting from a pollution incident at, on or mitigating beyond the site; and also provide coverage for incidents occurring during transportation of pollutants.

**Required if box is checked** .

#### MINIMUM LIMITS OF INSURANCE

Contractor shall maintain limits no less than the following, **if required under above scope**:

- A. Commercial General Liability: \$1,000,000 combined single limit per occurrence for bodily injury, and property damage and \$1,000,000 per occurrence for personal injury. The general aggregate shall be twice the required occurrence limit. Minimum General Aggregate shall be no less than \$2,000,000 or a project/contract specific aggregate of \$1,000,000.

- B. Owners and Contractors Protective Liability (OCP): \$1,000,000 combined single limit per occurrence for bodily injury and property damage.
- C. Business Automobile Liability: \$1,000,000 combined single limit per accident for bodily injury and property damage.
- D. Workers' Compensation and Employers' Liability: Workers' Compensation coverage with statutory limits and Employers' Liability limits of \$500,000 per accident.
- E. Builder's Risk: Shall insure against "All Risk" of physical damage, including water damage (flood and hydrostatic pressure not excluded), on a completed replacement cost basis.
- F. Environmental Impairment/Pollution Liability: \$1,000,000 combined single limit per occurrence for bodily injury, property damage and remediation costs.

### **DEDUCTIBLES AND SELF-INSURED RETENTIONS**

Any deductibles or self-insured retentions must be declared to and approved by the member. At the option of the member, either: the insurer shall reduce or eliminate such deductibles or self-insured retentions as respects the member, its officials, employees, agents and volunteers; or the Contractor shall procure a bond guaranteeing payment of losses and related investigation, claim administration and defense expenses.

### **OTHER INSURANCE PROVISIONS**

The policies are to contain, or be endorsed to contain, the following provisions:

#### **A. General Liability and Automobile Liability Coverages**

1. The member, its officials, agents, employees and volunteers are to be covered as additional insureds as respects: liability arising out of the Contractor's work, including activities performed by or on behalf of the Contractor; products and completed operations of the Contractor; premises owned, leased or used by the Contractor; or automobiles owned, leased, hired or borrowed by the Contractor. The coverage shall contain no special limitations on the scope of protection afforded to the member, its officials, agents, employees and volunteers.
2. The Contractor's insurance coverage shall be primary as respects the member, its officials, employees, agents and volunteers. Any insurance or self-insurance maintained by the member, its officials, agents, employees and volunteers shall be excess of Contractor's insurance and shall not contribute with it.
3. Any failure to comply with reporting provisions of the policies shall not affect coverage provided to the member, its officials, employees, agents and volunteers.
4. The Contractor's insurance shall contain a Severability of Interests/Cross Liability clause or language stating that Contractor's insurance shall apply separately to each insured against whom claim is made or suit is brought, except with respect to the limits of the insurer's liability.
5. If any commercial general liability insurance is being provided under an excess

or umbrella liability policy that does not “follow form,” then the Contractor shall be required to name the member, its officials, employees, agents and volunteers as additional insureds.

6. All general liability coverages shall be provided on an occurrence policy form. Claims-made general liability policies will not be accepted.
7. The contractor and all subcontractors hereby agree to waive any limitation as to the amount of contribution recoverable against them by member. This specifically includes any limitation imposed by any state statute, regulation, or case law including any Workers’ Compensation Act provision that applies a limitation to the amount recoverable in contribution such as Kotecki v. Cyclops Welding.

**B. Workers' Compensation and Employers' Liability Coverage**

The insurer shall agree to waive all rights of subrogation against the member, its officials, employees, agents and volunteers for losses arising from work performed by Contractor for the municipality.

1. NCCI Alternate Employer Endorsement (WC 000301) in place to insure that workers’ compensation coverage applies under contractor’s coverage rather than member’s if the member is borrowing, leasing or in day to day control of contractors employee.

**Required if box is checked** .

**C. Professional Liability (Required if box is checked )**

1. Professional liability insurance with limits not less than \$1,000,00 each claim with respect to negligent acts, errors and omissions in connection with professional services to be provided under the contract, with a deductible not-to-exceed \$50,000 without prior written approval.
2. If the policy is written on a claims-made form, the retroactive date must be equal to or preceding the effective date of the contract. In the event the policy is cancelled, non-renewed or switched to an occurrence form, the Contractor shall be required to purchase supplemental extending reporting period coverage for a period of not less than three (3) years.
3. Provide a certified copy of actual policy for review.
4. Recommended Required Coverage (architect, engineer, surveyor, consultant): Professional liability insurance that provides indemnification and defense for injury or damage arising out of acts, errors, or omissions in providing the following professional services, but not limited to the following:
  - a. Preparing, approving or failure to prepare or approve maps, drawings, opinions, report, surveys, change orders, designs or specifications;
  - b. Providing direction, instruction, supervision, inspection, engineering services or failing to provide them, if that is the primary cause of injury or damage.

**D. All Coverages**

Each insurance policy required shall have the member expressly endorsed onto the policy as a Cancellation Notice Recipient. Should any of the policies be cancelled before the expiration date thereof, notice will be delivered in accordance with the policy provisions.

### **ACCEPTABILITY OF INSURERS**

Insurance is to be placed with insurers with a Best's rating of no less than A-, VII and licensed to do business in the State of Illinois.

### **VERIFICATION OF COVERAGE**

Contractor shall furnish the member with certificates of insurance naming the member, its officials, employees, agents and volunteers as additional insureds (Exhibit D), and with original endorsements affecting coverage required by this clause. The certificates and endorsements for each insurance policy are to be signed by a person authorized by that insurer to bind coverage on its behalf. The certificates and endorsements are to be received and approved by the member before any work commences. The following additional insured endorsements may be utilized: ISO Additional Insured Endorsements CG 2010 (Exhibit A) or CG 2026 (Exhibit B), and CG 2037 (Exhibit C) – Completed Operations, where required. The member reserves the right to request full certified copies of the insurance policies and endorsements.

### **SUBCONTRACTORS**

Contractor shall include all subcontractors as insureds under its policies or shall furnish separate certificates and endorsements for each subcontractor. All coverages for subcontractors shall be subject to all of the requirements stated herein.

### **ASSUMPTION OF LIABILITY**

The contractor assumes liability for all injury to or death of any person or persons including employees of the contractor, any sub-contractor, any supplier or any other person and assumes liability for all damage to property sustained by any person or persons occasioned by or in any way arising out of any work performed pursuant to this agreement.

## **II. INDEMNITY/HOLD HARMLESS PROVISION**

To the fullest extent permitted by law, the Contractor hereby agrees to defend, indemnify and hold harmless the member, its officials, employees and agents against all injuries, deaths, loss, damages, claims, patent claims, suits, liabilities, judgments, cost and expenses, which may in anywise accrue against the member, its officials, agents and employees, arising in whole or in part or in consequence of the performance of this work by the Contractor, its employees, or subcontractors, or which may in anywise result therefore, except that arising out of the sole legal cause of the member, its employees or agents, the Contractor shall, at its own expense, appear, defend and pay all charges of attorneys and all costs and other expenses arising therefore or incurred in connections therewith, and, if any judgment shall be rendered against the member, its officials, employees and agents, in any such action, the Contractor shall, at its own expense, satisfy and discharge the same.

Contractor expressly understands and agrees that any performance bond or insurance policies required by this contract, or otherwise provided by the Contractor, shall in no way limit the responsibility to indemnify, keep and save harmless and defend the member, its

officials, employees and agents as herein provided.

The Contractor further agrees that to the extent that money is due the Contractor by virtue of this contract as shall be considered necessary in the judgment of the member, may be retained by the member to protect itself against said loss until such claims, suits, or judgments shall have been settled or discharged and/or evidence to that effect shall have been furnished to the satisfaction of the member.

### **III. SAFETY/LOSS PREVENTION**

#### **Safety/Loss Prevention Program Requirements**

- Successful bidder will provide written confirmation that a safety/loss prevention program was in place at least 90 days prior to submitting the bid proposal.
- Evidence of completed employee safety training can be provided.

#### **Regulatory Requirements**

- Successful bidder must comply with all applicable laws, regulations, and rules promulgated by any Federal, State, County, Municipal and/or other governmental unit or regulatory body now in effect or which may be in effect during the performance of the work. Included within the scope of the laws, regulations, and rules referred to in this paragraph but in no way to operate as a limitation, are Occupational Safety & Health Act (OSHA), Illinois Department of Labor (IDOL), Department of Transportation, all forms of traffic regulations, public utility, Intrastate and Interstate Commerce Commission regulations, Workers' Compensation Laws, Prevailing Wage Laws, the Social Security Act of the Federal Government and any of its titles, the Illinois Department of Human Rights, Human Rights Commission, or EEOC statutory provisions and rules and regulations.
- Evidence of specific regulatory compliance will be provided by bidder, if required by owner.

EXHIBIT A

POLICY NUMBER:

COMMERCIAL GENERAL LIABILITY  
CG 20 10 07 04

THIS ENDORSEMENT CHANGES THE POLICY. PLEASE READ IT CAREFULLY.

**ADDITIONAL INSURED – OWNERS, LESSEES OR  
CONTRACTORS – SCHEDULED PERSON OR  
ORGANIZATION**

This endorsement modifies insurance provided under the following:

COMMERCIAL GENERAL LIABILITY COVERAGE PART

SCHEDULE

Name Of Additional Insured Person(s) Or Organization(s):	Location(s) Of Covered Operations

Information required to complete this Schedule, if not shown above, will be shown in the Declarations.

A. Section II – Who Is An Insured is amended to include as an additional insured the person(s) or organization(s) shown in the Schedule, but only with respect to liability for "bodily injury", "property damage" or "personal and advertising injury" caused, in whole or in part, by:

1. Your acts or omissions; or
2. The acts or omissions of those acting on your behalf;

in the performance of your ongoing operations for the additional insured(s) at the location(s) designated above.

B. With respect to the insurance afforded to these additional insureds, the following additional exclusions apply:

This insurance does not apply to "bodily injury" or "property damage" occurring after:

1. All work, including materials, parts or equipment furnished in connection with such work, on the project (other than service, maintenance or repairs) to be performed by or on behalf of the additional insured(s) at the location of the covered operations has been completed; or
2. That portion of "your work" out of which the injury or damage arises has been put to its intended use by any person or organization other than another contractor or subcontractor engaged in performing operations for a principal as a part of the same project.



**EXHIBIT**

**C**

POLICY NUMBER:

**COMMERCIAL GENERAL LIABILITY**  
CG 20 37 07 04

**THIS ENDORSEMENT CHANGES THE POLICY. PLEASE READ IT CAREFULLY.**

**ADDITIONAL INSURED – OWNERS, LESSEES OR  
CONTRACTORS – COMPLETED OPERATIONS**

This endorsement modifies insurance provided under the following:

COMMERCIAL GENERAL LIABILITY COVERAGE PART

**SCHEDULE**

Name Of Additional Insured Person(s) Or Organization(s):	Location And Description Of Completed Operations
Information required to complete this Schedule, if not shown above, will be shown in the Declarations.	

**Section II – Who Is An Insured** is amended to include as an additional insured the person(s) or organization(s) shown in the Schedule, but only with respect to liability for "bodily injury" or "property damage" caused, in whole or in part, by "your work" at the location designated and described in the schedule of this endorsement performed for that additional insured and included in the "products-completed operations hazard".



**NOT FOR BID**

APPENDIX 4  
SWPPP & IEPA FORMS

**NOT FOR BID**



Storm Water Pollution Prevention Plan

Route VARIOUS
Section
County DUPAGE

Marked Rte.
Project No.
Contract No.

This plan has been prepared to comply with the provisions of the National Pollutant Discharge Elimination System (NPDES) Permit No. ILR10 (Permit ILR10), issued by the Illinois Environmental Protection Agency (IEPA) for storm water discharges from construction site activities.

I certify under penalty of law that this document and all attachments were prepared under my direction or supervision in accordance with a system designed to assure that qualified personnel properly gathered and evaluated the information submitted. Based on my inquiry of the person or persons who manage the system, or those persons directly responsible for gathering the information, the information submitted is, to the best of my knowledge and belief, true, accurate and complete. I am aware that there are significant penalties for submitting false information, including the possibility of fine and imprisonment for knowing violations.

Vydas Juskelis, P.E.
Print Name
Director of Public Works
Title
Village of Villa Park
Agency

Signature
Date

I. Site Description:

A. Provide a description of the project location (include latitude and longitude):

The proposed improvements are located throughout various streets in the Village of Villa Park (Latitude 41°53'19.8", Longitude 87°58'44.9").

B. Provide a description of the construction activity which is the subject of this plan:

The 2017 Street Improvements consist of various roadway improvement methods including hot-mix asphalt (HMA) resurfacing and HMA pavement reconstruction. Roadways consisting of pavement resurfacing will have pavement patching and spot curb and gutter replacement based on field conditions. The pavement reconstruction areas (with the exception of Washington Street) will be composed of 2" HMA surface course, 4" HMA binder course, and 6" aggregate base course supported on geotechnical fabric or geogrid. In addition, there will be sidewalk replacement at intersections to meet Public Right-of-Way Accessibility Guidelines (PROWAG), some drainage and utility improvements, pavement markings, erosion and sediment control, landscaping, and all collateral work necessary to complete the project.

C. Provide the estimated duration of this project:

This project will be under construction for approximately 4 months.

D. The total area of the construction site is estimated to be 15.1 acres.

The total area of the site estimated to be disturbed by excavation, grading or other activities is 8.81 acres.

E. The following is a weighted average of the runoff coefficient for this project after construction activities are completed:

C=0.60

F. List all soils found within project boundaries. Include map unit name, slope information, and erosivity:

See the attached NRCS Soil Maps.

G. Provide an aerial extent of wetland acreage at the site:

Not Applicable

H. Provide a description of potentially erosive areas associated with this project:

This project is located throughout residential areas of the Village. There are little to no concerns with erosive areas because there is typically no more than 10' of impact to the parkways where curb and gutter is being replaced.

I. The following is a description of soil disturbing activities by stages, their locations, and their erosive factors (e.g. steepness of slopes, length of slopes, etc):

The proposed profiles are designed to match the existing profiles of the various roadways which are relatively flat. The roadway slopes range from 0.3% to 4%. The parkway cross-slopes range from 1% to 8%.

J. See the erosion control plans and/or drainage plans for this contract for information regarding drainage patterns, approximate slopes anticipated before and after major grading activities, locations where vehicles enter or exit the site and controls to prevent offsite sediment tracking (to be added after contractor identifies locations), areas of soil disturbance, the location of major structural and non-structural controls identified in the plan, the location of areas where stabilization practices are expected to occur, surface waters (including wetlands) and locations where storm water is discharged to surface water including wetlands.

K. Identify who owns the drainage system (municipality or agency) this project will drain into:

Storm sewer system is operated and owned by the Village of Villa Park.

L. The following is a list of General NPDES ILR40 permittees within whose reporting jurisdiction this project is located.

Village of Villa Park

M. The following is a list of receiving water(s) and the ultimate receiving water(s) for this site. The location of the receiving waters can be found on the erosion and sediment control plans:

All runoff is drained by closed storm sewer systems which eventually outlet into Sugar Creek.

N. Describe areas of the site that are to be protected or remain undisturbed. These areas may include steep slopes, highly erodible soils, streams, stream buffers, specimen trees, natural vegetation, nature preserves, etc.

All existing trees and other mature vegetation will be protected by the use of temporary fence. The Contractor is to follow the applicable erosion and sediment control requirements of the Illinois Urban Manual.

O. The following sensitive environmental resources are associated with this project, and may have the potential to be impacted by the proposed development:

- Floodplain – Sugar Creek at Cross Street (potential impacts not anticipated)
- Wetland Riparian
- Threatened and Endangered Species
- Historic Preservation
- 303(d) Listed receiving waters for suspended solids, turbidity, or siltation
- Receiving waters with Total Maximum Daily Load (TMDL) for sediment, total suspended solids, turbidity or siltation
- Applicable Federal, Tribal, State or Local Programs
- Other

1. 303(d) Listed receiving waters (fill out this section if checked above):

a. The name(s) of the listed water body, and identification of all pollutants causing impairment:

b. Provide a description of how erosion and sediment control practices will prevent a discharge of sediment resulting from a storm event equal to or greater than a twenty-five (25) year, twenty-four (24) hour rainfall event:

- c. Provide a description of the location(s) of direct discharge from the project site to the 303(d) water body:
- d. Provide a description of the location(s) of any dewatering discharges to the MS4 and/or water body:

2. TMDL (fill out this section if checked above)

- a. The name(s) of the listed water body:
- b. Provide a description of the erosion and sediment control strategy that will be incorporated into the site design that is consistent with the assumptions and requirements of the TMDL:
- c. If a specific numeric waste load allocation has been established that would apply to the project's discharges, provide a description of the necessary steps to meet that allocation:

P. The following pollutants of concern will be associated with this construction project:

- |   |  |
|---|--|
| <input checked="" type="checkbox"/> Soil Sediment             | <input checked="" type="checkbox"/> Petroleum (gas, diesel, oil, kerosene, hydraulic oil / fluids) |
| <input checked="" type="checkbox"/> Concrete                  | <input checked="" type="checkbox"/> Antifreeze / Coolants  |
| <input checked="" type="checkbox"/> Concrete Truck Waste      | <input checked="" type="checkbox"/> Waste water from cleaning construction equipment               |
| <input checked="" type="checkbox"/> Concrete Curing Compounds | <input type="checkbox"/> Other (specify)   |
| <input type="checkbox"/> Solid Waste Debris                   | <input type="checkbox"/> Other (specify)   |
| <input type="checkbox"/> Paints                               | <input type="checkbox"/> Other (specify)   |
| <input type="checkbox"/> Solvents                             | <input type="checkbox"/> Other (specify)   |
| <input checked="" type="checkbox"/> Fertilizers / Pesticides  | <input type="checkbox"/> Other (specify)   |

II. Controls:

This section of the plan addresses the controls that will be implemented for each of the major construction activities described in I.C. above and for all use areas, borrow sites, and waste sites. For each measure discussed, the Contractor will be responsible for its implementation as indicated. The Contractor shall provide to the Resident Engineer a plan for the implementation of the measures indicated. The Contractor, and subcontractors, will notify the Resident Engineer of any proposed changes, maintenance, or modifications to keep construction activities compliant with the Permit ILR10. Each such Contractor has signed the required certification on forms which are attached to, and are a part of, this plan:

- A. **Erosion and Sediment Controls:** At a minimum, controls must be coordinated, installed and maintained to:
  1. Minimize the amount of soil exposed during construction activity;
  2. Minimize the disturbance of steep slopes;
  3. Maintain natural buffers around surface waters, direct storm water to vegetated areas to increase sediment removal and maximize storm water infiltration, unless infeasible;
  4. Minimize soil compaction and, unless infeasible, preserve topsoil.
- B. **Stabilization Practices:** Provided below is a description of interim and permanent stabilization practices, including site-specific scheduling of the implementation of the practices. Site plans will ensure that existing vegetation is preserved where attainable and disturbed portions of the site will be stabilized. Stabilization practices may include but are not limited to: temporary seeding, permanent seeding, mulching, geotextiles, sodding, vegetative buffer strips, protection of trees, preservation of mature vegetation, and other appropriate measures. Except as provided below in II(B)(1) and II(B)(2), stabilization measures shall be initiated **immediately** where construction activities have temporarily or permanently ceased, but in no case more than **one (1) day** after the construction activity in that portion of the site has temporarily or permanently ceases on all disturbed portions of the site where construction will not occur for a period of fourteen (14) or more calendar days.

1. Where the initiation of stabilization measures is precluded by snow cover, stabilization measures shall be initiated as soon as practicable.
2. On areas where construction activity has temporarily ceased and will resume after fourteen (14) days, a temporary stabilization method can be used.

The following stabilization practices will be used for this project:

- |   |   |
|---|---|
| <input checked="" type="checkbox"/> Preservation of Mature Vegetation | <input type="checkbox"/> Erosion Control Blanket / Mulching |
| <input type="checkbox"/> Vegetated Buffer Strips                      | <input checked="" type="checkbox"/> Sodding                 |
| <input checked="" type="checkbox"/> Protection of Trees               | <input type="checkbox"/> Geotextiles                        |
| <input checked="" type="checkbox"/> Temporary Erosion Control Seeding | <input type="checkbox"/> Other (specify)                    |
| <input type="checkbox"/> Temporary Turf (Seeding, Class 7)            | <input type="checkbox"/> Other (specify)                    |
| <input type="checkbox"/> Temporary Mulching                           | <input type="checkbox"/> Other (specify)                    |
| <input type="checkbox"/> Permanent Seeding                            | <input type="checkbox"/> Other (specify)                    |

Describe how the stabilization practices listed above will be utilized during construction:

Protection of Trees and Mature Vegetation – Prior to the start of any construction activities, tree pruning and tree root pruning will take place within the construction area. In addition, temporary fence will be placed around all existing trees and mature vegetation within and near the work zone to prevent any damage as directed by the Engineer.

Temporary Erosion Control Seeding – This item will be applied to all bare soil areas every seven days to minimize the amount of exposed surface areas.

Describe how the stabilization practices listed above will be utilized after construction activities have been completed:

Sodding – This item will be placed according to the landscaping plans at the end of each major stage of construction to permanently stabilize the disturbed areas.

- C. **Structural Practices:** Provided below is a description of structural practices that will be implemented, to the degree attainable, to divert flows from exposed soils, store flows or otherwise limit runoff and the discharge of pollutants from exposed areas of the site. Such practices may include but are not limited to: perimeter erosion barrier, earth dikes, drainage swales, sediment traps, ditch checks, subsurface drains, pipe slope drains, level spreaders, storm drain inlet protection, rock outlet protection, reinforced soil retaining systems, gabions, and temporary or permanent sediment basins. The installation of these devices may be subject to Section 404 of the Clean Water Act.

The following structural practices will be used for this project:

- |  |  |
|--|--|
| <input checked="" type="checkbox"/> Perimeter Erosion Barrier    | <input type="checkbox"/> Rock Outlet Protection  |
| <input type="checkbox"/> Temporary Ditch Check                   | <input type="checkbox"/> Riprap                  |
| <input checked="" type="checkbox"/> Storm Drain Inlet Protection | <input type="checkbox"/> Gabions                 |
| <input type="checkbox"/> Sediment Trap                           | <input type="checkbox"/> Slope Mattress          |
| <input type="checkbox"/> Temporary Pipe Slope Drain              | <input type="checkbox"/> Retaining Walls         |
| <input type="checkbox"/> Temporary Sediment Basin                | <input type="checkbox"/> Slope Walls             |
| <input type="checkbox"/> Temporary Stream Crossing               | <input type="checkbox"/> Concrete Revetment Mats |
| <input type="checkbox"/> Stabilized Construction Exits           | <input type="checkbox"/> Level Spreaders         |
| <input type="checkbox"/> Turf Reinforcement Mats                 | <input type="checkbox"/> Other: (specify)        |
| <input type="checkbox"/> Permanent Check Dams                    | <input type="checkbox"/> Other: (specify)        |
| <input type="checkbox"/> Permanent Sediment Basin                | <input type="checkbox"/> Other: (specify)        |
| <input type="checkbox"/> Aggregate Ditch                         | <input type="checkbox"/> Other: (specify)        |
| <input type="checkbox"/> Paved Ditch                             | <input type="checkbox"/> Other: (specify)        |

Describe how the structural practices listed above will be utilized during construction:

Perimeter Erosion Barrier – Silt fence will be used to prevent uncontrolled sheet flow from discharging off the job site.

Storm Drain Inlet Protection – Inlet filters will be used in all open grate structures within the project area to prevent silt and sediment from entering the drainage system.

Describe how the structural practices listed above will be utilized after construction activities have been completed:

**D. Treatment Chemicals**

Will polymer flocculants or treatment chemicals be utilized on this project:  Yes  No

If yes above, identify where and how polymer flocculants or treatment chemicals will be utilized on this project.

**E. Permanent Storm Water Management Controls:** Provided below is a description of measures that will be installed during the construction process to control volume and pollutants in storm water discharges that will occur after construction operations have been completed. The installation of these devices may be subject to Section 404 of the Clean Water Act.

1. Such practices may include but are not limited to: storm water detention structures (including wet ponds), storm water retention structures, flow attenuation by use of open vegetated swales and natural depressions, infiltration of runoff on site, and sequential systems (which combine several practices).

The practices selected for implementation were determined on the basis of the technical guidance in Chapter 41 (Construction Site Storm Water Pollution Control) of the IDOT Bureau of Design and Environment Manual. If practices other than those discussed in Chapter 41 are selected for implementation or if practices are applied to situations different from those covered in Chapter 41, the technical basis for such decisions will be explained below.

2. Velocity dissipation devices will be placed at discharge locations and along the length of any outfall channel as necessary to provide a non-erosive velocity flow from the structure to a water course so that the natural physical and biological characteristics and functions are maintained and protected (e.g. maintenance of hydrologic conditions such as the hydroperiod and hydrodynamics present prior to the initiation of construction activities).

Description of permanent storm water management controls:

Separation of combined sewers is being done on the remaining portion of sewer at the upstream end of Home Avenue. The existing storm sewer systems will continue to outlet to the same outfalls.

**F. Approved State or Local Laws:** The management practices, controls and provisions contained in this plan will be in accordance with IDOT specifications, which are at least as protective as the requirements contained in the Illinois Environmental Protection Agency's Illinois Urban Manual. Procedures and requirements specified in applicable sediment and erosion site plans or storm water management plans approved by local officials shall be described or incorporated by reference in the space provided below. Requirements specified in sediment and erosion site plans, site permits, storm water management site plans or site permits approved by local officials that are applicable to protecting surface water resources are, upon submittal of an NOI, to be authorized to discharge under the Permit ILR10 incorporated by reference and are enforceable under this permit even if they are not specifically included in the plan.

Description of procedures and requirements specified in applicable sediment and erosion site plans or storm water management plans approved by local officials:

All practices and procedures shall be in accordance with the IDOT Standard Specifications for Road and Bridge Construction, IDOT Supplemental Specifications and Recurring Special Provisions, SWCD Illinois Urban Manual, and the special provisions and details shown in the Plans.

**G. Contractor Required Submittals:** Prior to conducting any professional services at the site covered by this plan, the Contractor and each subcontractor responsible for compliance with the permit shall submit to the Resident Engineer a Contractor Certification Statement, BDE 2342a.

1. The Contractor shall provide a construction schedule containing an adequate level of detail to show major activities with implementation of pollution prevention BMPs, including the following items:

- Approximate duration of the project, including each stage of the project
  - Rainy season, dry season, and winter shutdown dates
  - Temporary stabilization measures to be employed by contract phases
  - Mobilization timeframe
  - Mass clearing and grubbing/roadside clearing dates
  - Deployment of Erosion Control Practices
  - Deployment of Sediment Control Practices (including stabilized construction entrances/exits)
  - Deployment of Construction Site Management Practices (including concrete washout facilities, chemical storage, refueling locations, etc.)
  - Paving, saw-cutting, and any other pavement related operations
  - Major planned stockpiling operations
  - Timeframe for other significant long-term operations or activities that may plan non-storm water discharges such as dewatering, grinding, etc.
  - Permanent stabilization activities for each area of the project
2. The Contractor and each subcontractor shall provide, as an attachment to their signed Contractor Certification Statement, a discussion of how they will comply with the requirements of the permit in regard to the following items and provide a graphical representation showing location and type of BMPs to be used when applicable:
- Vehicle Entrances and Exits – Identify type and location of stabilized construction entrances and exits to be used and how they will be maintained.
  - Material Delivery, Storage and Use – Discuss where and how materials including chemicals, concrete curing compounds, petroleum products, etc. will be stored for this project.
  - Stockpile Management – Identify the location of both on-site and off-site stockpiles. Discuss what BMPs will be used to prevent pollution of storm water from stockpiles.
  - Waste Disposal – Discuss methods of waste disposal that will be used for this project.
  - Spill Prevention and Control – Discuss steps that will be taken in the event of a material spill (chemicals, concrete curing compounds, petroleum, etc.)
  - Concrete Residuals and Washout Wastes – Discuss the location and type of concrete washout facilities to be used on this project and how they will be signed and maintained.
  - Litter Management – Discuss how litter will be maintained for this project (education of employees, number of dumpsters, frequency of dumpster pick-up, etc.).
  - Vehicle and Equipment Fueling – Identify equipment fueling locations for this project and what BMPs will be used to ensure containment and spill prevention.
  - Vehicle and Equipment Cleaning and Maintenance – Identify where equipment cleaning and maintenance locations for this project and what BMPs will be used to ensure containment and spill prevention.
  - Dewatering Activities – Identify the controls which will be used during dewatering operations to ensure sediments will not leave the construction site.
  - Polymer Flocculants and Treatment Chemicals – Identify the use and dosage of treatment chemicals and provide the Resident Engineer with Material Safety Data Sheets. Describe procedures on how the chemicals will be used and identify who will be responsible for the use and application of these chemicals. The selected individual must be trained on the established procedures.
  - Additional measures indicated in the plan.

### III. Maintenance:

When requested by the Contractor, the Resident Engineer will provide general maintenance guides to the Contractor for the practices associated with this project. The following additional procedures will be used to maintain, in good and effective operating conditions, the vegetation, erosion and sediment control measures and other protective measures identified in this plan. It will be the Contractor's responsibility to attain maintenance guidelines for any manufactured BMPs which are to be installed and maintained per manufacture's specifications.

#### **IV. Inspections:**

Qualified personnel shall inspect disturbed areas of the construction site which have not yet been finally stabilized, structural control measures, and locations where vehicles and equipment enter and exit the site using IDOT Storm Water Pollution Prevention Plan Erosion Control Inspection Report (BC 2259). Such inspections shall be conducted at least once every seven (7) calendar days and within twenty-four (24) hours of the end of a storm or by the end of the following business or work day that is 0.5 inch or greater or equivalent snowfall.

Inspections may be reduced to once per month when construction activities have ceased due to frozen conditions. Weekly inspections will recommence when construction activities are conducted, or if there is 0.5" or greater rain event, or a discharge due to snowmelt occurs.

If any violation of the provisions of this plan is identified during the conduct of the construction work covered by this plan, the Resident Engineer shall notify the appropriate IEPA Field Operations Section office by email at: [epa.swnoncomp@illinois.gov](mailto:epa.swnoncomp@illinois.gov), telephone or fax within twenty-four (24) hours of the incident. The Resident Engineer shall then complete and submit an "Incidence of Non-Compliance" (ION) report for the identified violation within five (5) days of the incident. The Resident Engineer shall use forms provided by IEPA and shall include specific information on the cause of noncompliance, actions which were taken to prevent any further causes of noncompliance, and a statement detailing any environmental impact which may have resulted from the noncompliance. All reports of non-compliance shall be signed by a responsible authority in accordance with Part VI. G of the Permit ILR10.

The Incidence of Non-Compliance shall be mailed to the following address:

Illinois Environmental Protection Agency  
Division of Water Pollution Control  
Attn: Compliance Assurance Section  
1021 North Grand East  
Post Office Box 19276  
Springfield, Illinois 62794-9276

Additional Inspections Required:

#### **V. Failure to Comply:**

Failure to comply with any provisions of this Storm Water Pollution Prevention Plan will result in the implementation of a National Pollutant Discharge Elimination System/Erosion and Sediment Control Deficiency Deduction against the Contractor and/or penalties under the Permit ILR10 which could be passed on to the Contractor.



Prior to conducting any professional services at the site covered by this contract, the Contractor and every subcontractor must complete and return to the Resident Engineer the following certification. A separate certification must be submitted by each firm. Attach to this certification all items required by Section II.G of the Storm Water Pollution Prevention Plan (SWPPP) which will be handled by the Contractor/subcontractor completing this form.

Route VARIOUS

Marked Rte. \_\_\_\_\_

Section \_\_\_\_\_

Project No. \_\_\_\_\_

County DUPAGE

Contract No. \_\_\_\_\_

This certification statement is a part of SWPPP for the project described above, in accordance with the General NPDES Permit No. ILR10 issued by the Illinois Environmental Protection Agency.

I certify under penalty of law that I understand the terms of the Permit No. ILR 10 that authorizes the storm water discharges associated with industrial activity from the construction site identified as part of this certification.

In addition, I have read and understand all of the information and requirements stated in SWPPP for the above mentioned project; I have received copies of all appropriate maintenance procedures; and, I have provided all documentation required to be in compliance with the Permit ILR10 and SWPPP and will provide timely updates to these documents as necessary.

Contractor

Sub-Contractor

\_\_\_\_\_  
Print Name

\_\_\_\_\_  
Signature

\_\_\_\_\_  
Title

\_\_\_\_\_  
Date

\_\_\_\_\_  
Name of Firm

\_\_\_\_\_  
Telephone

\_\_\_\_\_  
Street Address

\_\_\_\_\_  
City/State/ZIP

Items which this Contractor/subcontractor will be responsible for as required in Section II.G. of SWPPP:

\_\_\_\_\_  
\_\_\_\_\_  
\_\_\_\_\_  
\_\_\_\_\_

# Custom Soil Resource Report Map—Hydrologic Soil Group (Adams Street)



































Map Scale: 1:4,640 if printed on A landscape (11" x 8.5") sheet.

0 50 100 200 300 Meters

0 200 400 800 1200 Feet

Map projection: Web Mercator Corner coordinates: WGS84 Edge tics: UTM Zone 16N WGS84

### MAP LEGEND

- Area of Interest (AOI)**
-  Area of Interest (AOI)
- Soils**
- Soil Rating Polygons**
-  A
  -  A/D
  -  B
  -  B/D
  -  C
  -  C/D
  -  D
  -  Not rated or not available
- Soil Rating Lines**
-  A
  -  A/D
  -  B
  -  B/D
  -  C
  -  C/D
  -  D
  -  Not rated or not available
- Soil Rating Points**
-  A
  -  A/D
  -  B
  -  B/D
- Water Features**
-  Streams and Canals
- Transportation**
-  Rails
  -  Interstate Highways
  -  US Routes
  -  Major Roads
  -  Local Roads
- Background**
-  Aerial Photography
- Soils**
-  C
  -  C/D
  -  D
  -  Not rated or not available

### MAP INFORMATION

The soil surveys that comprise your AOI were mapped at 1:12,000.

Warning: Soil Map may not be valid at this scale.

Enlargement of maps beyond the scale of mapping can cause misunderstanding of the detail of mapping and accuracy of soil line placement. The maps do not show the small areas of contrasting soils that could have been shown at a more detailed scale.

Please rely on the bar scale on each map sheet for map measurements.

Source of Map: Natural Resources Conservation Service  
 Web Soil Survey URL:  
 Coordinate System: Web Mercator (EPSG:3857)

Maps from the Web Soil Survey are based on the Web Mercator projection, which preserves direction and shape but distorts distance and area. A projection that preserves area, such as the Albers equal-area conic projection, should be used if more accurate calculations of distance or area are required.

This product is generated from the USDA-NRCS certified data as of the version date(s) listed below.

Soil Survey Area: DuPage County, Illinois  
 Survey Area Data: Version 12, Sep 16, 2016

Soil map units are labeled (as space allows) for map scales 1:50,000 or larger.

Date(s) aerial images were photographed: Mar 13, 2012—Mar 28, 2012

The orthophoto or other base map on which the soil lines were compiled and digitized probably differs from the background imagery displayed on these maps. As a result, some minor shifting of map unit boundaries may be evident.

**Table—Hydrologic Soil Group (Adams Street)**

Hydrologic Soil Group— Summary by Map Unit — DuPage County, Illinois (IL043)				
Map unit symbol	Map unit name	Rating	Acres in AOI	Percent of AOI
854B	Markham-Ashkum-Beecher complex, 1 to 6 percent slopes	C/D	22.6	100.0%
<b>Totals for Area of Interest</b>			<b>22.6</b>	<b>100.0%</b>

**Rating Options—Hydrologic Soil Group (Adams Street)**

*Aggregation Method:* Dominant Condition

*Component Percent Cutoff:* None Specified

*Tie-break Rule:* Higher

NOT FOR BIDD

Custom Soil Resource Report  
Map—Hydrologic Soil Group (Belden Avenue)







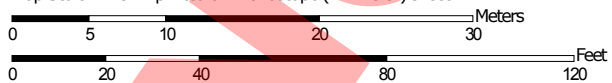



























Soil Map may not be valid at this scale.

Map Scale: 1:492 if printed on A landscape (11" x 8.5") sheet.



Map projection: Web Mercator Corner coordinates: WGS84 Edge tics: UTM Zone 16N WGS84

**MAP LEGEND**

- Area of Interest (AOI)**  
 Area of Interest (AOI)
- Soils**
- Soil Rating Polygons**
-  A
  -  A/D
  -  B
  -  B/D
  -  C
  -  C/D
  -  D
  -  Not rated or not available
- Soil Rating Lines**
-  A
  -  A/D
  -  B
  -  B/D
  -  C
  -  C/D
  -  D
  -  Not rated or not available
- Soil Rating Points**
-  A
  -  A/D
  -  B
  -  B/D
- Water Features**
-  Streams and Canals
- Transportation**
-  Rails
  -  Interstate Highways
  -  US Routes
  -  Major Roads
  -  Local Roads
- Background**
-  Aerial Photography
- Soils (continued)**
-  C
  -  C/D
  -  D
  -  Not rated or not available

**MAP INFORMATION**

The soil surveys that comprise your AOI were mapped at 1:12,000.

Warning: Soil Map may not be valid at this scale.

Enlargement of maps beyond the scale of mapping can cause misunderstanding of the detail of mapping and accuracy of soil line placement. The maps do not show the small areas of contrasting soils that could have been shown at a more detailed scale.

Please rely on the bar scale on each map sheet for map measurements.

Source of Map: Natural Resources Conservation Service  
 Web Soil Survey URL:  
 Coordinate System: Web Mercator (EPSG:3857)

Maps from the Web Soil Survey are based on the Web Mercator projection, which preserves direction and shape but distorts distance and area. A projection that preserves area, such as the Albers equal-area conic projection, should be used if more accurate calculations of distance or area are required.

This product is generated from the USDA-NRCS certified data as of the version date(s) listed below.

Soil Survey Area: DuPage County, Illinois  
 Survey Area Data: Version 12, Sep 16, 2016

Soil map units are labeled (as space allows) for map scales 1:50,000 or larger.

Date(s) aerial images were photographed: Mar 13, 2012—Mar 28, 2012

The orthophoto or other base map on which the soil lines were compiled and digitized probably differs from the background imagery displayed on these maps. As a result, some minor shifting of map unit boundaries may be evident.

**Table—Hydrologic Soil Group (Belden Avenue)**

Hydrologic Soil Group— Summary by Map Unit — DuPage County, Illinois (IL043)				
Map unit symbol	Map unit name	Rating	Acres in AOI	Percent of AOI
531B	Markham silt loam, 2 to 4 percent slopes	C	0.7	80.8%
854B	Markham-Ashkum-Beecher complex, 1 to 6 percent slopes	C/D	0.2	19.2%
<b>Totals for Area of Interest</b>			<b>0.9</b>	<b>100.0%</b>

**Rating Options—Hydrologic Soil Group (Belden Avenue)**



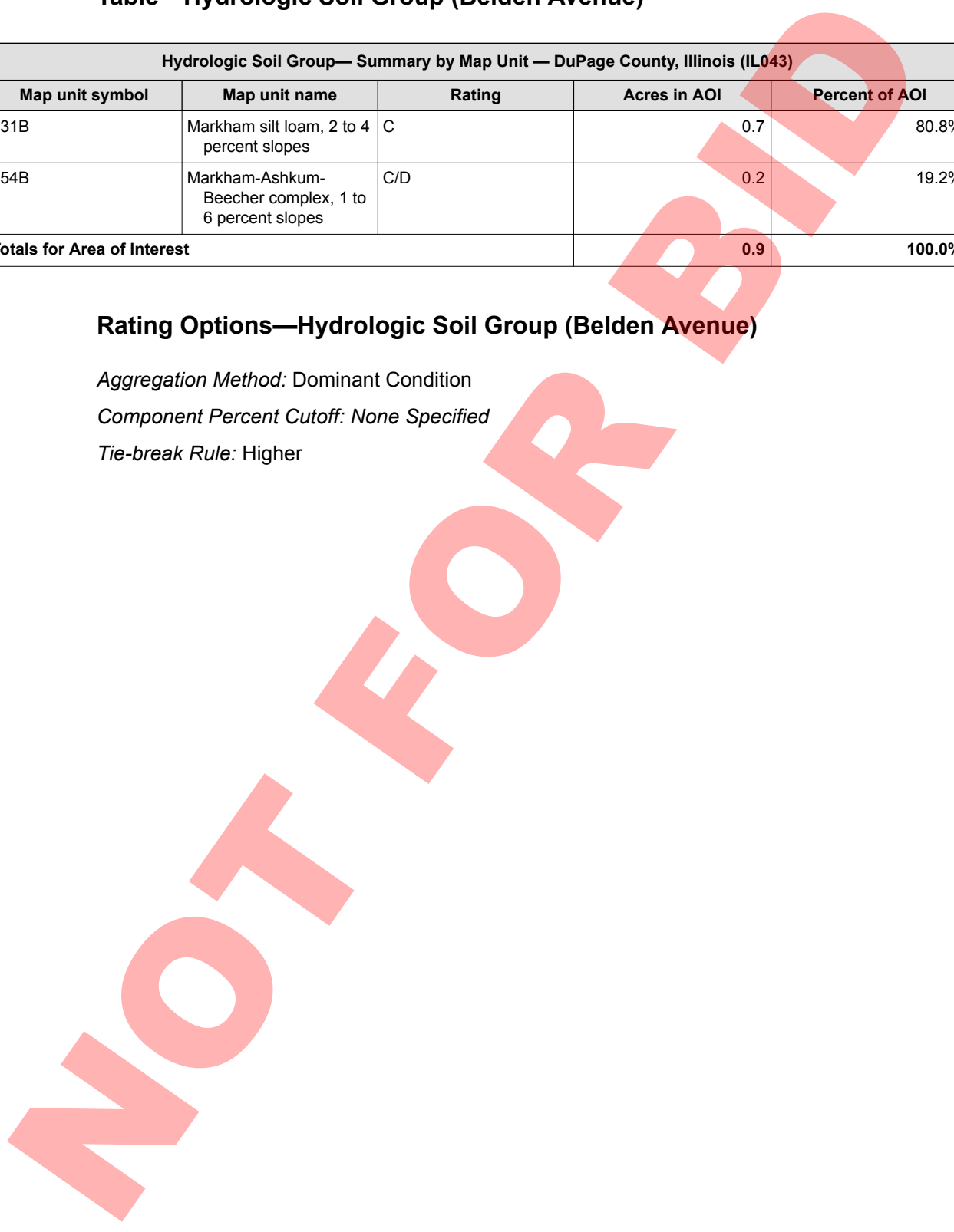





























*Aggregation Method:* Dominant Condition  
*Component Percent Cutoff:* None Specified  
*Tie-break Rule:* Higher



Custom Soil Resource Report  
Map—Hydrologic Soil Group (Cross Street)



### MAP LEGEND

- Area of Interest (AOI)**
  -  Area of Interest (AOI)
- Soils**
  - Soil Rating Polygons**
    -  A
    -  A/D
    -  B
    -  B/D
    -  C
    -  C/D
    -  D
    -  Not rated or not available
  - Soil Rating Lines**
    -  A
    -  A/D
    -  B
    -  B/D
    -  C
    -  C/D
    -  D
    -  Not rated or not available
  - Soil Rating Points**
    -  A
    -  A/D
    -  B
    -  B/D
- Soils**
  -  C
  -  C/D
  -  D
  -  Not rated or not available
- Water Features**
  -  Streams and Canals
- Transportation**
  -  Rails
  -  Interstate Highways
  -  US Routes
  -  Major Roads
  -  Local Roads
- Background**
  -  Aerial Photography

### MAP INFORMATION

The soil surveys that comprise your AOI were mapped at 1:12,000.

Warning: Soil Map may not be valid at this scale.

Enlargement of maps beyond the scale of mapping can cause misunderstanding of the detail of mapping and accuracy of soil line placement. The maps do not show the small areas of contrasting soils that could have been shown at a more detailed scale.

Please rely on the bar scale on each map sheet for map measurements.

Source of Map: Natural Resources Conservation Service  
 Web Soil Survey URL:  
 Coordinate System: Web Mercator (EPSG:3857)

Maps from the Web Soil Survey are based on the Web Mercator projection, which preserves direction and shape but distorts distance and area. A projection that preserves area, such as the Albers equal-area conic projection, should be used if more accurate calculations of distance or area are required.

This product is generated from the USDA-NRCS certified data as of the version date(s) listed below.

Soil Survey Area: DuPage County, Illinois  
 Survey Area Data: Version 12, Sep 16, 2016

Soil map units are labeled (as space allows) for map scales 1:50,000 or larger.

Date(s) aerial images were photographed: Mar 13, 2012—Mar 28, 2012

The orthophoto or other base map on which the soil lines were compiled and digitized probably differs from the background imagery displayed on these maps. As a result, some minor shifting of map unit boundaries may be evident.

**Table—Hydrologic Soil Group (Cross Street)**

Hydrologic Soil Group— Summary by Map Unit — DuPage County, Illinois (IL043)				
Map unit symbol	Map unit name	Rating	Acres in AOI	Percent of AOI
805B	Orthents, clayey, undulating	D	0.9	100.0%
<b>Totals for Area of Interest</b>			<b>0.9</b>	<b>100.0%</b>

**Rating Options—Hydrologic Soil Group (Cross Street)**

*Aggregation Method:* Dominant Condition

*Component Percent Cutoff:* None Specified

*Tie-break Rule:* Higher

NOT FOR BLD







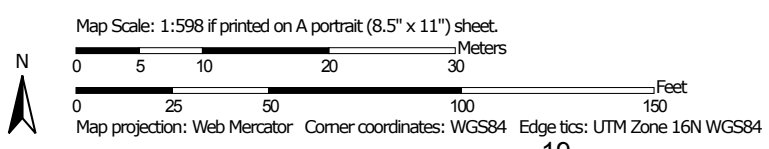

























Custom Soil Resource Report  
Map—Hydrologic Soil Group (Fire Station)



Soil Map may not be valid at this scale.



### MAP LEGEND

- Area of Interest (AOI)**
-  Area of Interest (AOI)
- Soils**
- Soil Rating Polygons**
-  A
  -  A/D
  -  B
  -  B/D
  -  C
  -  C/D
  -  D
  -  Not rated or not available
- Soil Rating Lines**
-  A
  -  A/D
  -  B
  -  B/D
  -  C
  -  C/D
  -  D
  -  Not rated or not available
- Soil Rating Points**
-  A
  -  A/D
  -  B
  -  B/D
- Soils**
-  C
  -  C/D
  -  D
  -  Not rated or not available
- Water Features**
-  Streams and Canals
- Transportation**
-  Rails
  -  Interstate Highways
  -  US Routes
  -  Major Roads
  -  Local Roads
- Background**
-  Aerial Photography

### MAP INFORMATION

The soil surveys that comprise your AOI were mapped at 1:12,000.

Warning: Soil Map may not be valid at this scale.

Enlargement of maps beyond the scale of mapping can cause misunderstanding of the detail of mapping and accuracy of soil line placement. The maps do not show the small areas of contrasting soils that could have been shown at a more detailed scale.

Please rely on the bar scale on each map sheet for map measurements.

Source of Map: Natural Resources Conservation Service  
 Web Soil Survey URL:  
 Coordinate System: Web Mercator (EPSG:3857)

Maps from the Web Soil Survey are based on the Web Mercator projection, which preserves direction and shape but distorts distance and area. A projection that preserves area, such as the Albers equal-area conic projection, should be used if more accurate calculations of distance or area are required.

This product is generated from the USDA-NRCS certified data as of the version date(s) listed below.

Soil Survey Area: DuPage County, Illinois  
 Survey Area Data: Version 12, Sep 16, 2016

Soil map units are labeled (as space allows) for map scales 1:50,000 or larger.

Date(s) aerial images were photographed: Mar 13, 2012—Mar 28, 2012

The orthophoto or other base map on which the soil lines were compiled and digitized probably differs from the background imagery displayed on these maps. As a result, some minor shifting of map unit boundaries may be evident.

**Table—Hydrologic Soil Group (Fire Station)**

Hydrologic Soil Group— Summary by Map Unit — DuPage County, Illinois (IL043)				
Map unit symbol	Map unit name	Rating	Acres in AOI	Percent of AOI
531B	Markham silt loam, 2 to 4 percent slopes	C	0.4	27.4%
805B	Orthents, clayey, undulating	D	1.1	72.6%
<b>Totals for Area of Interest</b>			<b>1.5</b>	<b>100.0%</b>

**Rating Options—Hydrologic Soil Group (Fire Station)**

*Aggregation Method: Dominant Condition*

*Component Percent Cutoff: None Specified*







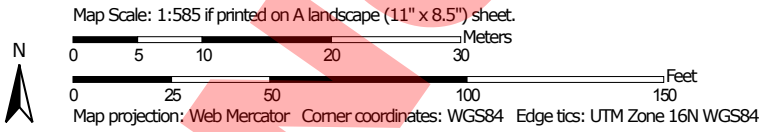

























*Tie-break Rule: Higher*

NOT FOR BIDD

Custom Soil Resource Report  
Map—Hydrologic Soil Group (Golf Course Parking Lot)



### MAP LEGEND

- Area of Interest (AOI)**
-  Area of Interest (AOI)
- Soils**
- Soil Rating Polygons**
-  A
  -  A/D
  -  B
  -  B/D
  -  C
  -  C/D
  -  D
  -  Not rated or not available
- Soil Rating Lines**
-  A
  -  A/D
  -  B
  -  B/D
  -  C
  -  C/D
  -  D
  -  Not rated or not available
- Soil Rating Points**
-  A
  -  A/D
  -  B
  -  B/D
- Water Features**
-  Streams and Canals
- Transportation**
-  Rails
  -  Interstate Highways
  -  US Routes
  -  Major Roads
  -  Local Roads
- Background**
-  Aerial Photography
- Soils (Color Key)**
-  C
  -  C/D
  -  D
  -  Not rated or not available

### MAP INFORMATION

The soil surveys that comprise your AOI were mapped at 1:12,000.

Warning: Soil Map may not be valid at this scale.

Enlargement of maps beyond the scale of mapping can cause misunderstanding of the detail of mapping and accuracy of soil line placement. The maps do not show the small areas of contrasting soils that could have been shown at a more detailed scale.

Please rely on the bar scale on each map sheet for map measurements.

Source of Map: Natural Resources Conservation Service  
 Web Soil Survey URL:  
 Coordinate System: Web Mercator (EPSG:3857)

Maps from the Web Soil Survey are based on the Web Mercator projection, which preserves direction and shape but distorts distance and area. A projection that preserves area, such as the Albers equal-area conic projection, should be used if more accurate calculations of distance or area are required.

This product is generated from the USDA-NRCS certified data as of the version date(s) listed below.

Soil Survey Area: DuPage County, Illinois  
 Survey Area Data: Version 12, Sep 16, 2016

Soil map units are labeled (as space allows) for map scales 1:50,000 or larger.

Date(s) aerial images were photographed: Mar 13, 2012—Mar 28, 2012

The orthophoto or other base map on which the soil lines were compiled and digitized probably differs from the background imagery displayed on these maps. As a result, some minor shifting of map unit boundaries may be evident.

**Table—Hydrologic Soil Group (Golf Course Parking Lot)**

Hydrologic Soil Group— Summary by Map Unit — DuPage County, Illinois (IL043)				
Map unit symbol	Map unit name	Rating	Acres in AOI	Percent of AOI
146A	Elliott silt loam, 0 to 2 percent slopes	C/D	0.4	32.5%
805B	Orthents, clayey, undulating	D	0.8	67.5%
<b>Totals for Area of Interest</b>			<b>1.2</b>	<b>100.0%</b>

**Rating Options—Hydrologic Soil Group (Golf Course Parking Lot)**

*Aggregation Method: Dominant Condition*  
*Component Percent Cutoff: None Specified*  
*Tie-break Rule: Higher*

NOT FOR BIDD







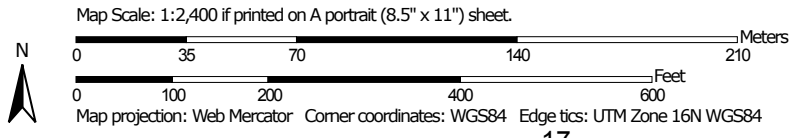

























Custom Soil Resource Report  
Map—Hydrologic Soil Group (Grant Avenue)



Soil Map may not be valid at this scale.



**MAP LEGEND**

- Area of Interest (AOI)**  
 Area of Interest (AOI)
- Soils**
- Soil Rating Polygons**
-  A
  -  A/D
  -  B
  -  B/D
  -  C
  -  C/D
  -  D
  -  Not rated or not available
- Soil Rating Lines**
-  A
  -  A/D
  -  B
  -  B/D
  -  C
  -  C/D
  -  D
  -  Not rated or not available
- Soil Rating Points**
-  A
  -  A/D
  -  B
  -  B/D
- Water Features**
-  Streams and Canals
- Transportation**
-  Rails
  -  Interstate Highways
  -  US Routes
  -  Major Roads
  -  Local Roads
- Background**
-  Aerial Photography
- Soils (continued)**
-  C
  -  C/D
  -  D
  -  Not rated or not available

**MAP INFORMATION**

The soil surveys that comprise your AOI were mapped at 1:12,000.

Warning: Soil Map may not be valid at this scale.

Enlargement of maps beyond the scale of mapping can cause misunderstanding of the detail of mapping and accuracy of soil line placement. The maps do not show the small areas of contrasting soils that could have been shown at a more detailed scale.

Please rely on the bar scale on each map sheet for map measurements.

Source of Map: Natural Resources Conservation Service  
 Web Soil Survey URL:  
 Coordinate System: Web Mercator (EPSG:3857)

Maps from the Web Soil Survey are based on the Web Mercator projection, which preserves direction and shape but distorts distance and area. A projection that preserves area, such as the Albers equal-area conic projection, should be used if more accurate calculations of distance or area are required.

This product is generated from the USDA-NRCS certified data as of the version date(s) listed below.

Soil Survey Area: DuPage County, Illinois  
 Survey Area Data: Version 12, Sep 16, 2016

Soil map units are labeled (as space allows) for map scales 1:50,000 or larger.

Date(s) aerial images were photographed: Mar 13, 2012—Mar 28, 2012

The orthophoto or other base map on which the soil lines were compiled and digitized probably differs from the background imagery displayed on these maps. As a result, some minor shifting of map unit boundaries may be evident.

**Table—Hydrologic Soil Group (Grant Avenue)**

Hydrologic Soil Group— Summary by Map Unit — DuPage County, Illinois (IL043)				
Map unit symbol	Map unit name	Rating	Acres in AOI	Percent of AOI
805B	Orthents, clayey, undulating	D	4.5	100.0%
<b>Totals for Area of Interest</b>			<b>4.5</b>	<b>100.0%</b>

**Rating Options—Hydrologic Soil Group (Grant Avenue)**

*Aggregation Method:* Dominant Condition

*Component Percent Cutoff:* None Specified







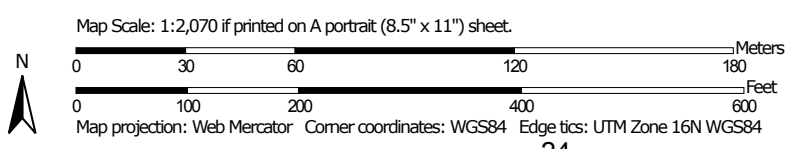

























*Tie-break Rule:* Higher

NOT FOR BLD

Custom Soil Resource Report  
Map—Hydrologic Soil Group (Harvard Avenue)



### MAP LEGEND

- Area of Interest (AOI)**
  -  Area of Interest (AOI)
- Soils**
  - Soil Rating Polygons**
    -  A
    -  A/D
    -  B
    -  B/D
    -  C
    -  C/D
    -  D
    -  Not rated or not available
  - Soil Rating Lines**
    -  A
    -  A/D
    -  B
    -  B/D
    -  C
    -  C/D
    -  D
    -  Not rated or not available
  - Soil Rating Points**
    -  A
    -  A/D
    -  B
    -  B/D
- Soils**
  -  C
  -  C/D
  -  D
  -  Not rated or not available
- Water Features**
  -  Streams and Canals
- Transportation**
  -  Rails
  -  Interstate Highways
  -  US Routes
  -  Major Roads
  -  Local Roads
- Background**
  -  Aerial Photography

### MAP INFORMATION

The soil surveys that comprise your AOI were mapped at 1:12,000.

Warning: Soil Map may not be valid at this scale.

Enlargement of maps beyond the scale of mapping can cause misunderstanding of the detail of mapping and accuracy of soil line placement. The maps do not show the small areas of contrasting soils that could have been shown at a more detailed scale.

Please rely on the bar scale on each map sheet for map measurements.

Source of Map: Natural Resources Conservation Service  
 Web Soil Survey URL:  
 Coordinate System: Web Mercator (EPSG:3857)

Maps from the Web Soil Survey are based on the Web Mercator projection, which preserves direction and shape but distorts distance and area. A projection that preserves area, such as the Albers equal-area conic projection, should be used if more accurate calculations of distance or area are required.

This product is generated from the USDA-NRCS certified data as of the version date(s) listed below.

Soil Survey Area: DuPage County, Illinois  
 Survey Area Data: Version 12, Sep 16, 2016

Soil map units are labeled (as space allows) for map scales 1:50,000 or larger.

Date(s) aerial images were photographed: Mar 13, 2012—Mar 28, 2012

The orthophoto or other base map on which the soil lines were compiled and digitized probably differs from the background imagery displayed on these maps. As a result, some minor shifting of map unit boundaries may be evident.

**Table—Hydrologic Soil Group (Harvard Avenue)**

Hydrologic Soil Group— Summary by Map Unit — DuPage County, Illinois (IL043)				
Map unit symbol	Map unit name	Rating	Acres in AOI	Percent of AOI
223B	Varna silt loam, 2 to 4 percent slopes	C	1.6	22.3%
232A	Ashkum silty clay loam, 0 to 2 percent slopes	C/D	0.8	10.3%
330A	Peotone silty clay loam, 0 to 2 percent slopes	C/D	0.7	9.5%
805B	Orthents, clayey, undulating	D	2.9	38.8%
854B	Markham-Ashkum-Beecher complex, 1 to 6 percent slopes	C/D	1.4	19.0%
<b>Totals for Area of Interest</b>			<b>7.4</b>	<b>100.0%</b>

**Rating Options—Hydrologic Soil Group (Harvard Avenue)**

*Aggregation Method: Dominant Condition*  
*Component Percent Cutoff: None Specified*  
*Tie-break Rule: Higher*

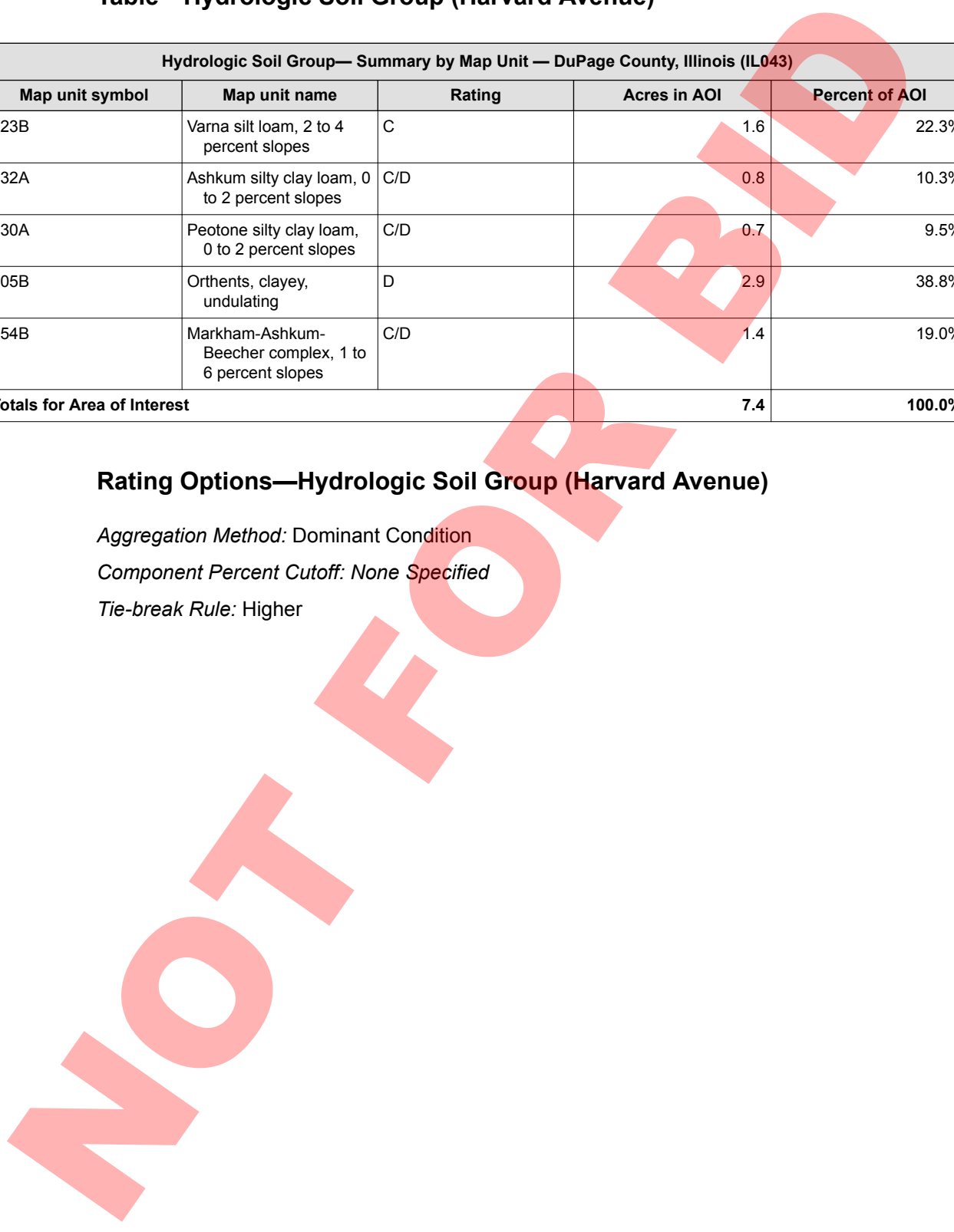

Custom Soil Resource Report  
Map—Hydrologic Soil Group (Ridge Road)



































Soil Map may not be valid at this scale.

Map Scale: 1:2,300 if printed on A landscape (11" x 8.5") sheet.



Map projection: Web Mercator Corner coordinates: WGS84 Edge tics: UTM Zone 16N WGS84

### MAP LEGEND

- Area of Interest (AOI)**
  -  Area of Interest (AOI)
- Soils**
  - Soil Rating Polygons**
    -  A
    -  A/D
    -  B
    -  B/D
    -  C
    -  C/D
    -  D
    -  Not rated or not available
  - Soil Rating Lines**
    -  A
    -  A/D
    -  B
    -  B/D
    -  C
    -  C/D
    -  D
    -  Not rated or not available
  - Soil Rating Points**
    -  A
    -  A/D
    -  B
    -  B/D
- Soils (continued)**
  -  C
  -  C/D
  -  D
  -  Not rated or not available
- Water Features**
  -  Streams and Canals
- Transportation**
  -  Rails
  -  Interstate Highways
  -  US Routes
  -  Major Roads
  -  Local Roads
- Background**
  -  Aerial Photography

### MAP INFORMATION

The soil surveys that comprise your AOI were mapped at 1:12,000.

Warning: Soil Map may not be valid at this scale.

Enlargement of maps beyond the scale of mapping can cause misunderstanding of the detail of mapping and accuracy of soil line placement. The maps do not show the small areas of contrasting soils that could have been shown at a more detailed scale.

Please rely on the bar scale on each map sheet for map measurements.

Source of Map: Natural Resources Conservation Service  
 Web Soil Survey URL:  
 Coordinate System: Web Mercator (EPSG:3857)

Maps from the Web Soil Survey are based on the Web Mercator projection, which preserves direction and shape but distorts distance and area. A projection that preserves area, such as the Albers equal-area conic projection, should be used if more accurate calculations of distance or area are required.

This product is generated from the USDA-NRCS certified data as of the version date(s) listed below.

Soil Survey Area: DuPage County, Illinois  
 Survey Area Data: Version 12, Sep 16, 2016

Soil map units are labeled (as space allows) for map scales 1:50,000 or larger.

Date(s) aerial images were photographed: Mar 13, 2012—Mar 28, 2012

The orthophoto or other base map on which the soil lines were compiled and digitized probably differs from the background imagery displayed on these maps. As a result, some minor shifting of map unit boundaries may be evident.

**Table—Hydrologic Soil Group (Ridge Road)**

Hydrologic Soil Group— Summary by Map Unit — DuPage County, Illinois (IL043)				
Map unit symbol	Map unit name	Rating	Acres in AOI	Percent of AOI
805B	Orthents, clayey, undulating	D	6.0	64.7%
854B	Markham-Ashkum-Beecher complex, 1 to 6 percent slopes	C/D	3.3	35.3%
<b>Totals for Area of Interest</b>			<b>9.3</b>	<b>100.0%</b>

**Rating Options—Hydrologic Soil Group (Ridge Road)**

*Aggregation Method:* Dominant Condition  
*Component Percent Cutoff:* None Specified  
*Tie-break Rule:* Higher

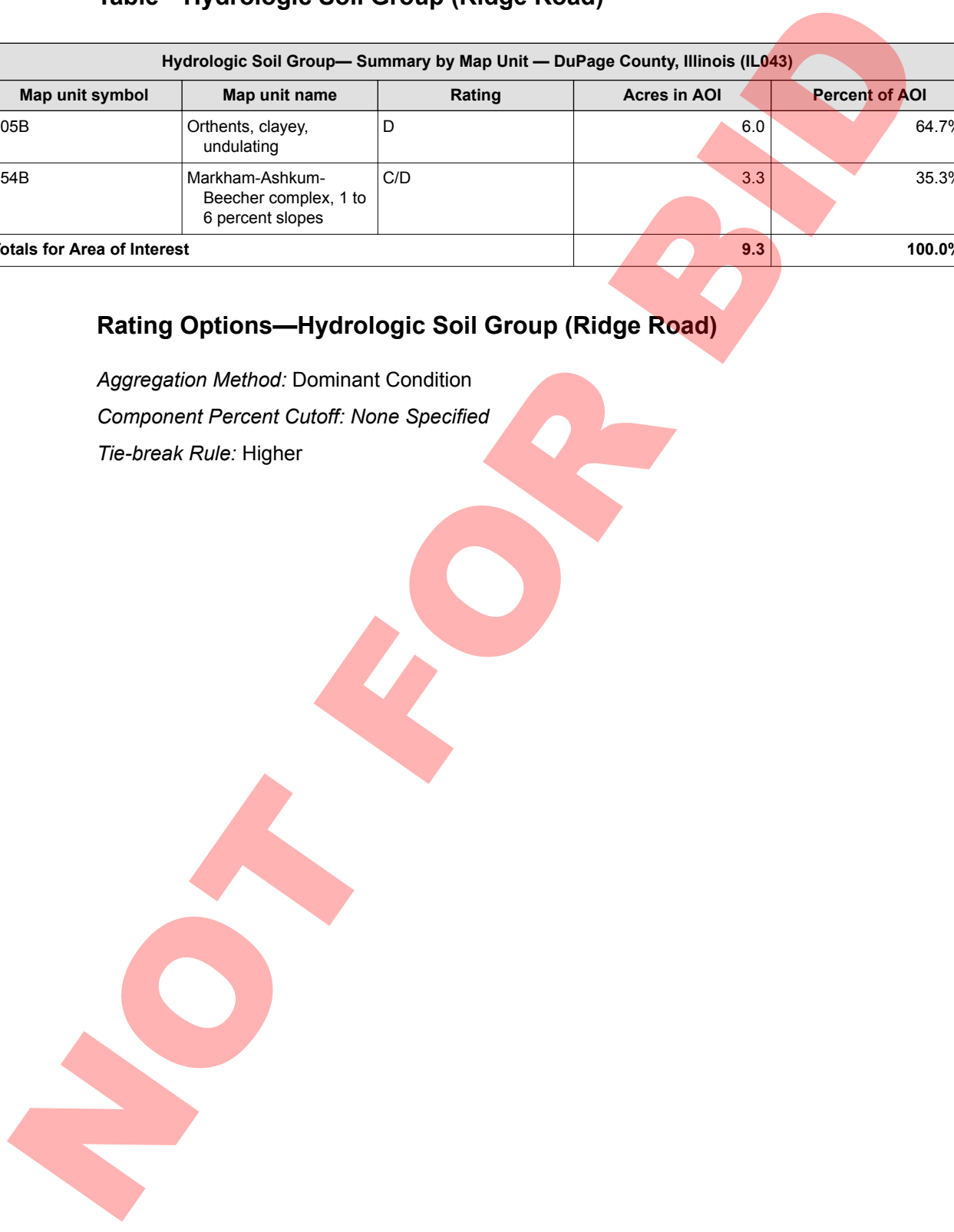







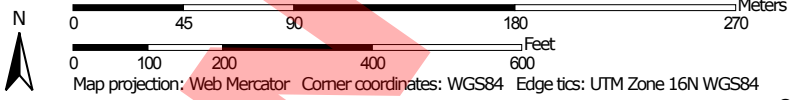

























Custom Soil Resource Report  
Map—Hydrologic Soil Group (Sunset Drive)



Map Scale: 1:3,080 if printed on A landscape (11" x 8.5") sheet.



**MAP LEGEND**

- Area of Interest (AOI)**
  -  Area of Interest (AOI)
- Soils**
  - Soil Rating Polygons**
    -  A
    -  A/D
    -  B
    -  B/D
    -  C
    -  C/D
    -  D
    -  Not rated or not available
  - Soil Rating Lines**
    -  A
    -  A/D
    -  B
    -  B/D
    -  C
    -  C/D
    -  D
    -  Not rated or not available
  - Soil Rating Points**
    -  A
    -  A/D
    -  B
    -  B/D
- Soils**
  -  C
  -  C/D
  -  D
  -  Not rated or not available
- Water Features**
  -  Streams and Canals
- Transportation**
  -  Rails
  -  Interstate Highways
  -  US Routes
  -  Major Roads
  -  Local Roads
- Background**
  -  Aerial Photography

**MAP INFORMATION**

The soil surveys that comprise your AOI were mapped at 1:12,000.

Warning: Soil Map may not be valid at this scale.

Enlargement of maps beyond the scale of mapping can cause misunderstanding of the detail of mapping and accuracy of soil line placement. The maps do not show the small areas of contrasting soils that could have been shown at a more detailed scale.

Please rely on the bar scale on each map sheet for map measurements.

Source of Map: Natural Resources Conservation Service  
 Web Soil Survey URL:  
 Coordinate System: Web Mercator (EPSG:3857)

Maps from the Web Soil Survey are based on the Web Mercator projection, which preserves direction and shape but distorts distance and area. A projection that preserves area, such as the Albers equal-area conic projection, should be used if more accurate calculations of distance or area are required.

This product is generated from the USDA-NRCS certified data as of the version date(s) listed below.

Soil Survey Area: DuPage County, Illinois  
 Survey Area Data: Version 12, Sep 16, 2016

Soil map units are labeled (as space allows) for map scales 1:50,000 or larger.

Date(s) aerial images were photographed: Mar 13, 2012—Mar 28, 2012

The orthophoto or other base map on which the soil lines were compiled and digitized probably differs from the background imagery displayed on these maps. As a result, some minor shifting of map unit boundaries may be evident.

**Table—Hydrologic Soil Group (Sunset Drive)**

Hydrologic Soil Group— Summary by Map Unit — DuPage County, Illinois (IL043)				
Map unit symbol	Map unit name	Rating	Acres in AOI	Percent of AOI
805B	Orthents, clayey, undulating	D	1.9	17.8%
854B	Markham-Ashkum-Beecher complex, 1 to 6 percent slopes	C/D	8.8	82.2%
<b>Totals for Area of Interest</b>			<b>10.6</b>	<b>100.0%</b>

**Rating Options—Hydrologic Soil Group (Sunset Drive)**

*Aggregation Method:* Dominant Condition  
*Component Percent Cutoff:* None Specified  
*Tie-break Rule:* Higher

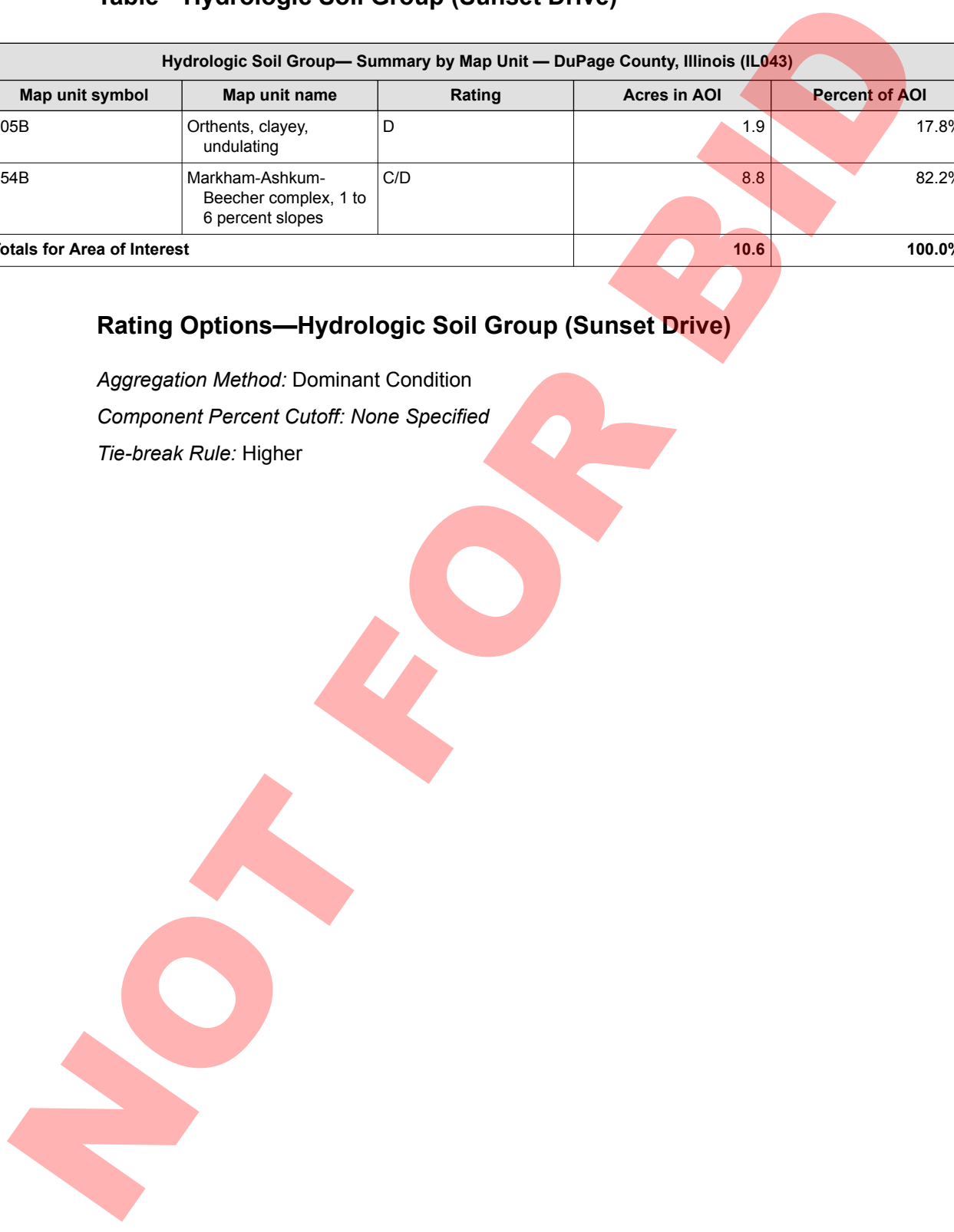

Custom Soil Resource Report  
Map—Hydrologic Soil Group (Washington Street)



































Map Scale: 1:818 if printed on A landscape (11" x 8.5") sheet.



Map projection: Web Mercator Corner coordinates: WGS84 Edge tics: UTM Zone 16N WGS84

### MAP LEGEND

- Area of Interest (AOI)**
  -  Area of Interest (AOI)
- Soils**
  - Soil Rating Polygons**
    -  A
    -  A/D
    -  B
    -  B/D
    -  C
    -  C/D
    -  D
    -  Not rated or not available
  - Soil Rating Lines**
    -  A
    -  A/D
    -  B
    -  B/D
    -  C
    -  C/D
    -  D
    -  Not rated or not available
  - Soil Rating Points**
    -  A
    -  A/D
    -  B
    -  B/D
- Soils**
  -  C
  -  C/D
  -  D
  -  Not rated or not available
- Water Features**
  -  Streams and Canals
- Transportation**
  -  Rails
  -  Interstate Highways
  -  US Routes
  -  Major Roads
  -  Local Roads
- Background**
  -  Aerial Photography

### MAP INFORMATION

The soil surveys that comprise your AOI were mapped at 1:12,000.

Warning: Soil Map may not be valid at this scale.

Enlargement of maps beyond the scale of mapping can cause misunderstanding of the detail of mapping and accuracy of soil line placement. The maps do not show the small areas of contrasting soils that could have been shown at a more detailed scale.

Please rely on the bar scale on each map sheet for map measurements.

Source of Map: Natural Resources Conservation Service  
 Web Soil Survey URL:  
 Coordinate System: Web Mercator (EPSG:3857)

Maps from the Web Soil Survey are based on the Web Mercator projection, which preserves direction and shape but distorts distance and area. A projection that preserves area, such as the Albers equal-area conic projection, should be used if more accurate calculations of distance or area are required.

This product is generated from the USDA-NRCS certified data as of the version date(s) listed below.

Soil Survey Area: DuPage County, Illinois  
 Survey Area Data: Version 12, Sep 16, 2016

Soil map units are labeled (as space allows) for map scales 1:50,000 or larger.

Date(s) aerial images were photographed: Mar 13, 2012—Mar 28, 2012

The orthophoto or other base map on which the soil lines were compiled and digitized probably differs from the background imagery displayed on these maps. As a result, some minor shifting of map unit boundaries may be evident.

**Table—Hydrologic Soil Group (Washington Street)**

Hydrologic Soil Group— Summary by Map Unit — DuPage County, Illinois (IL043)				
Map unit symbol	Map unit name	Rating	Acres in AOI	Percent of AOI
805B	Orthents, clayey, undulating	D	1.3	95.6%
830	Landfills		0.1	4.4%
<b>Totals for Area of Interest</b>			<b>1.3</b>	<b>100.0%</b>

**Rating Options—Hydrologic Soil Group (Washington Street)**

*Aggregation Method:* Dominant Condition

*Component Percent Cutoff:* None Specified

*Tie-break Rule:* Higher

NOT FOR BLD



Bureau of Water • 1021 North Grand Avenue East • P.O. Box 19276 • Springfield • Illinois • 62794-9276

## Division of Water Pollution Control Notice of Intent (NOI) for General Permit to Discharge Storm Water Associated with Construction Site Activities

*This fillable form may be completed online, a copy saved locally, printed and signed before it is submitted to the Permit Section at the above address.*

For Office Use Only

Permit No. ILR10 \_\_\_\_\_

### OWNER INFORMATION

Company/Owner Name: Village of Villa Park, DuPage County, Illinois  
Mailing Address: 11 West Home Avenue Phone: (630) 834-8505  
City: Villa Park State: IL Zip: 60181 Fax: (630) 834-8509  
Contact Person: Vydas Juskelis, P.E. E-mail: juskelis@invillapark.com  
Owner Type (select one) City

### CONTRACTOR INFORMATION

MS4 Community:  Yes  No

Contractor Name: \_\_\_\_\_  
Mailing Address: \_\_\_\_\_ Phone: \_\_\_\_\_  
City: \_\_\_\_\_ State: \_\_\_\_\_ Zip: \_\_\_\_\_ Fax: \_\_\_\_\_

### CONSTRUCTION SITE INFORMATION

Select One:  New  Change of information for: ILR10 \_\_\_\_\_  
Project Name: 2017 Street Improvements County: DuPage  
Street Address: Various Streets City: Villa Park IL Zip: 60181  
Latitude: 41 53 20 Longitude: -87 58 45 Various 39N&40N 11E  
(Deg) (Min) (Sec) (Deg) (Min) (Sec) Section Township Range  
Approximate Construction Start Date \_\_\_\_\_ Approximate Construction End Date \_\_\_\_\_

Total size of construction site in acres: 8.81  
If less than 1 acre, is the site part of a larger common plan of development?  
 Yes  No

Fee Schedule for Construction Sites:  
Less than 5 acres - \$250  
5 or more acres - \$750

### STORM WATER POLLUTION PREVENTION PLAN (SWPPP)

Has the SWPPP been submitted to the Agency?  Yes  No  
(Submit SWPPP electronically to: [epa.constilr10swppp@illinois.gov](mailto:epa.constilr10swppp@illinois.gov))  
Location of SWPPP for viewing: Address: \_\_\_\_\_ City: \_\_\_\_\_  
SWPPP contact information: Inspector qualifications: \_\_\_\_\_  
Contact Name: \_\_\_\_\_  
Phone: \_\_\_\_\_ Fax: \_\_\_\_\_ E-mail: \_\_\_\_\_  
Project inspector, if different from above Inspector qualifications: \_\_\_\_\_  
Inspector's Name: \_\_\_\_\_  
Phone: \_\_\_\_\_ Fax: \_\_\_\_\_ E-mail: \_\_\_\_\_

**TYPE OF CONSTRUCTION (select one)**

Construction Type Transportation

SIC Code: \_\_\_\_\_

Type a detailed description of the project:

The scope of work includes hot-mix asphalt (HMA) resurfacing and HMA pavement reconstruction. Roadways consisting of pavement resurfacing will have pavement patching and curb and gutter replacement based on field conditions. The pavement reconstruction areas (with the exception of Washington Street) will be composed of 2" HMA surface course, 4" HMA binder course, and 6" aggregate base course supported on geotechnical fabric or geogrid. In addition, there will be sidewalk replacement at intersections, drainage and utility improvements, pavement markings, erosion & sediment control, and landscaping work.

**HISTORIC PRESERVATION AND ENDANGERED SPECIES COMPLIANCE**

Has the project been submitted to the following state agencies to satisfy applicable requirements for compliance with Illinois law on:

Historic Preservation Agency     Yes     No

Endangered Species                 Yes     No

**RECEIVING WATER INFORMATION**

Does your storm water discharge directly to:     Waters of the State    or     Storm Sewer

Owner of storm sewer system: Village of Villa Park

Name of closest receiving water body to which you discharge: Sugar Creek

Mail completed form to: Illinois Environmental Protection Agency  
Division of Water Pollution Control  
Attn: Permit Section  
Post Office Box 19276  
Springfield, Illinois 62794-9276  
or call (217) 782-0610  
FAX: (217) 782-9891

Or submit electronically to: [epa.constilr10swppp@illinois.gov](mailto:epa.constilr10swppp@illinois.gov)

I certify under penalty of law that this document and all attachments were prepared under my direction and supervision in accordance with a system designed to assure that qualified personnel properly gather and evaluate the information submitted. Based on my inquiry of the person or persons who manage this system, or those persons directly responsible for gathering the information, the information submitted is, to the best of my knowledge and belief, true, accurate, and complete. I am aware that there are significant penalties for submitting false information, including the possibility of fine and imprisonment. In addition, I certify that the provisions of the permit, including the development and implementation of a storm water pollution prevention plan and a monitoring program plan, will be complied with.

*Any person who knowingly makes a false, fictitious, or fraudulent material statement, orally or in writing, to the Illinois EPA commits a Class 4 felony. A second or subsequent offense after conviction is a Class 3 felony. (415 ILCS 5/44(h))*

Owner Signature: \_\_\_\_\_

Vydas Juskelis, P.E.

Printed Name: \_\_\_\_\_

Date: \_\_\_\_\_

Director of Public Works

Title: \_\_\_\_\_

**INSTRUCTIONS FOR COMPLETION OF CONSTRUCTION ACTIVITY NOTICE OF INTENT (NOI) FORM**

Submit original, electronic or facsimile copies. Facsimile and/or electronic copies should be followed-up with submission of an original signature copy as soon as possible. Please write "copy" under the "For Office Use Only" box in the upper right hand corner of the first page.

***This fillable form may be completed online, a copy saved locally, printed and signed before it is submitted to the Permit Section at:***

Illinois Environmental Protection Agency  
Division of Water Pollution Control  
Permit Section  
Post Office Box 19276  
Springfield, Illinois 62794-9276  
or call (217) 782-0610  
FAX: (217) 782-9891

Or submit electronically to: [epa.constilr10swppp@illinois.gov](mailto:epa.constilr10swppp@illinois.gov)

**Reports must be typed or printed legibly and signed.**

Any facility that is not presently covered by the General NPDES Permit for Storm Water Discharges From Construction Site Activities is considered a new facility.

If this is a change in your facility information, renewal, etc., please fill in your permit number on the appropriate line, changes of information or permit renewal notifications do not require a fee.

**NOTE: FACILITY LOCATION IS NOT NECESSARILY THE FACILITY MAILING ADDRESS, BUT SHOULD DESCRIBE WHERE THE FACILITY IS LOCATED.**

Use the formats given in the following examples for correct form completion.

	Example	Format
Section	12	1 or 2 numerical digits
Township	12N	1 or 2 numerical digits followed by "N" or "S"
Range	12W	1 or 2 numerical digits followed by "E" or "W"

For the Name of Closest Receiving Waters, do not use terms such as ditch or channel. For unnamed tributaries, use terms which include at least a named main tributary such as "Unnamed Tributary to Sugar Creek to Sangamon River."

Submission of initial fee and an electronic submission of Storm Water Pollution Prevention Plan (SWPPP) for Initial Permit prior to the Notice of Intent being considered complete for coverage by the ILR10 General Permits. Please make checks payable to: Illinois EPA at the above address.

Construction sites with less than 5 acres of land disturbance - fee is \$250.

Construction sites with 5 or more acres of land disturbance - fee is \$750.

SWPPP should be submitted electronically to: [epa.constilr10swppp@illinois.gov](mailto:epa.constilr10swppp@illinois.gov) When submitting electronically, use Project Name and City as indicated on NOI form.



# Illinois Environmental Protection Agency

Bureau of Water • 1021 North Grand Avenue East • P.O. Box 19276 • Springfield • Illinois • 62794-9276

## Division of Water Pollution Control

### Construction Site Storm Water Discharge Incidence of Non-Compliance (ION)

*This fillable form may be completed online, a copy saved locally, printed and signed before it is submitted to the Compliance Assurance Section at the above address. You may email this completed form to:*

[epa.swnoncomp@illinois.gov](mailto:epa.swnoncomp@illinois.gov)

For Office Use Only

Permit No. ILR10 \_\_\_\_\_

Permittee Name: Village of Villa Park, DuPage County, Illinois

Address: 11 West Home Avenue

County: DuPage

City: Villa Park State: IL Zip: 60181

Phone: (630) 834-8505

Construction Site Name: 2017 Street Improvements

E-mail: juskelis@invillapark.com

Latitude: 41 53 20 Longitude: -87 58 45 Various 39N&40N 11E  
(Deg) (Min) (Sec) (Deg) (Min) (Sec) Section Township Range

#### Cause of Non-Compliance

\_\_\_\_\_  
\_\_\_\_\_  
\_\_\_\_\_

#### Actions Taken to Prevent Any Further Non-Compliance

\_\_\_\_\_  
\_\_\_\_\_  
\_\_\_\_\_

#### Environmental Impact Resulting From the Non-Compliance

\_\_\_\_\_  
\_\_\_\_\_  
\_\_\_\_\_

#### Actions Taken to Reduce the Environmental Impact Resulting From the Non-Compliance

\_\_\_\_\_  
\_\_\_\_\_  
\_\_\_\_\_

**Any person who knowingly makes a false, fictitious, or fraudulent material statement, orally or in writing, to the Illinois EPA commits a Class 4 felony. A second or subsequent offense after conviction is a Class 3 felony. (415 ILCS 5/44(h))**

Owner Signature:  
Vydas Juskelis, P.E.

Date:  
Director of Public Works

Printed Name:

Title:

This Agency is authorized to require this information under Section 4 and Title X of the Environmental Protection Act (415 ILCS 5/4, 5/39). Failure to disclose this information may result in: a civil penalty of not to exceed \$50,000 for the violation and an additional civil penalty of not to exceed \$10,000 for each day during which the violation continues (415 ILCS 5/42) and may also prevent this form from being processed and could result in your application being denied. This form has been approved by the Forms Management Center.

DIVISION OF WATER POLLUTION CONTROL  
ILLINOIS ENVIRONMENTAL PROTECTION AGENCY  
FIELD OPERATIONS SECTION

GUIDELINES FOR COMPLETION OF INCIDENCE OF NON-COMPLIANCE (ION) FORM

Complete and submit this form for any violation of the Storm Water Pollution Prevention Plan observed during any inspection conducted, including those not required by the SWPPP. Please adhere to the following guidelines:

Initial submission within 24 hours by email, telephone or fax (see region fax numbers) of any incidence of non-compliance for any violation. Submit email copy to: [epa.swnoncomp@illinois.gov](mailto:epa.swnoncomp@illinois.gov). After 24 hours notification, submit signed original ION within 5 days to the following address:

Illinois Environmental Protection Agency  
Division of Water Pollution Control  
Compliance Assurance #19  
Post Office Box 19276  
Springfield, Illinois 62794-9276

FIELD OPERATIONS HEADQUARTERS  
Bruce Yurdin, Manager  
Phone: 217/782-3362 Fax: 217/785-1225  
EMAIL: [epa.swnoncomp@illinois.gov](mailto:epa.swnoncomp@illinois.gov)

Region 1 - ROCKFORD  
Chuck Corley, Manager  
Phone: 815/987-7760 Fax: 815/987-7005

Region 2 - DESPLAINES  
Jay Patel, Manager  
Phone: 847/294-4000 Fax: 847/294-4058

Region 3 - PEORIA  
Jim Kammueler, Manager  
Phone: 309/693-5463 Fax: 309/693-5467

Region 4 - CHAMPAIGN  
Joe Koronkowski, Manager  
Phone: 217/278-5800 Fax: 217/278-5808

Region 5 - SPRINGFIELD  
Bruce Yurdin, FOS Manager  
Phone: 217/782-3362 Fax: 217/785-1225

Region 6 - COLLINSVILLE  
Bruce Yurdin, FOS Manager  
Phone: 217/782-3362 Fax: 217/785-1225

Region 7- MARION  
Byron Marks, Manager  
Phone: 618/993-7200 Fax: 618/997-5467

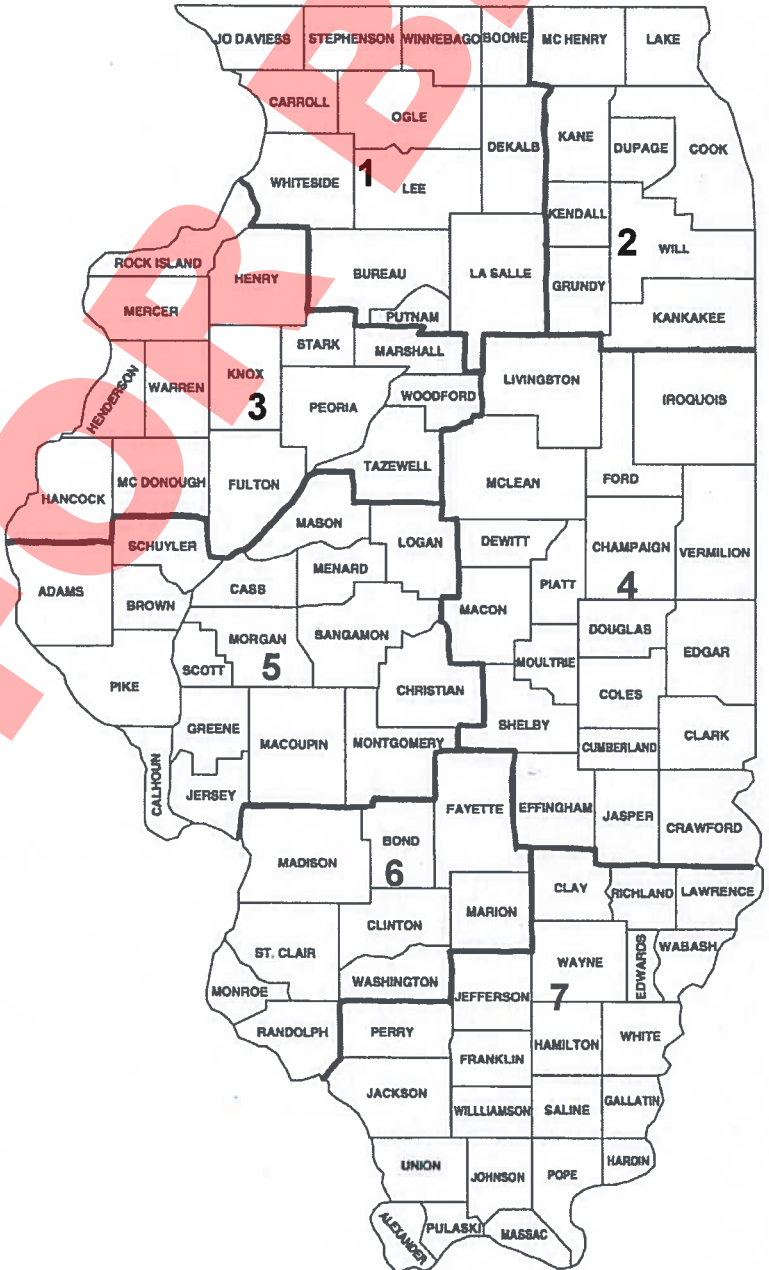



# Illinois Environmental Protection Agency

Bureau of Water • 1021 North Grand Avenue East • P.O. Box 19276 • Springfield • Illinois • 62794-9276

## Division of Water Pollution Control NOTICE OF TERMINATION (NOT) of Coverage under the General Permit for Storm Water Discharges Associated with Construction Site Activities

*This fillable form may be completed online, a copy saved locally, printed and signed before it is submitted to the Permit Section at the above address.*

### OWNER INFORMATION

Permit No. ILR10 \_\_\_\_\_

Owner Name: Village of Villa Park, DuPage County, Illinois

Owner Type (select one) City

Mailing Address: 11 West Home Avenue

Phone: (630) 834-8505

City: Villa Park State: IL Zip: 60181

Fax: (630) 834-8509

Contact Person: Vydas Juskelis, P.E.

E-mail: juskelis@invillapark.com

### CONTRACTOR INFORMATION

Contractor Name: \_\_\_\_\_

Mailing Address: \_\_\_\_\_

Phone: \_\_\_\_\_

City: \_\_\_\_\_ State: \_\_\_\_\_ Zip: \_\_\_\_\_

Fax: \_\_\_\_\_

### CONSTRUCTION SITE INFORMATION

Facility Name: 2017 Street Improvements

Street Address: Various Streets

City: Villa Park IL Zip: 60181

County: DuPage

NPDES Storm Water General Permit Number: ILR10

Latitude: 41 53 20 Longitude: -87 58 45 Various 39N&40N 11E  
(Deg) (Min) (Sec) (Deg) (Min) (Sec) Section Township Range

DATE PROJECT HAS BEEN COMPLETED AND STABILIZED: \_\_\_\_\_

**NOTE: Coverage under this permit cannot be terminated without the completion date.**

I certify under penalty of law that disturbed soils at the identified facility have been finally stabilized or that all storm water discharges associated with industrial activity from the identified facility that are authorized by an NPDES general permit have otherwise been eliminated. I understand that by submitting this notice of termination, that I am no longer authorized to discharge storm water associated with industrial activity by the general permit, and that discharging pollutants in storm water associated with industrial activity to Waters of the State is unlawful under the Environmental Protection Act and the Clean Water Act where the discharge is not authorized by an NPDES Permit.

**Any person who knowingly makes a false, fictitious, or fraudulent material statement, orally or in writing, to the Illinois EPA commits a Class 4 felony. A second or subsequent offense after conviction is a Class 3 felony. (415 ILCS 5/44(h))**

Owner Signature: \_\_\_\_\_

Date: \_\_\_\_\_

Mail completed form to: Illinois Environmental Protection Agency  
Division of Water Pollution Control, Attn: Permit Section  
1021 North Grand Avenue East  
P.O. Box 19276  
Springfield, Illinois 62794-9276

(Do not submit additional documentation unless requested)

This Agency is authorized to require this information under Section 4 and Title X of the Environmental Protection Act (415 ILCS 5/4, 5/39). Failure to disclose this information may result in: a civil penalty of not to exceed \$50,000 for the violation and an additional civil penalty of not to exceed \$10,000 for each day during which the violation continues (415 ILCS 5/42) and may also prevent this form from being processed and could result in your application being denied. This form has been approved by the Forms Management Center.

**GUIDELINES FOR COMPLETION OF NOTICE OF TERMINATION (NOT) FORM**

Please adhere to the following guidelines:

Submit original, electronic or facsimile copies. Facsimile and/or electronic copies should be followed-up with submission of an original signature copy as soon as possible.

Submit completed forms to:

Illinois Environmental Protection Agency  
 Division of Water Pollution Control, Attn: Permit Section  
 1021 North Grand Avenue East  
 P.O. Box 19276  
 Springfield, Illinois 62794-9276  
 or call (217) 782-0610  
 FAX: (217) 782-9891

Or submit electronically to: [epa.constilr10swppp@illinois.gov](mailto:epa.constilr10swppp@illinois.gov)

**Reports must be typed or printed legibly and signed.**

**NOTE: FACILITY LOCATION IS NOT NECESSARILY THE FACILITY MAILING ADDRESS, BUT SHOULD DESCRIBE WHERE THE FACILITY IS LOCATED.**

Use the formats given in the following examples for correct form completion.

	Example	Format
Section	12	1 or 2 numerical digits
Township	12N	1 or 2 numerical digits followed by "N" or "S"
Range	12W	1 or 2 numerical digits followed by "E" or "W"

Final stabilization has occurred when:

- (a) all soil disturbing activities at the site have been completed;
- (b) a uniform perennial vegetative cover with a density of 70% of the native background vegetative cover for the area has been established on all unpaved areas not covered by permanent structures; or
- (c) equivalent permanent stabilization measures have been employed.

APPENDIX 5  
PAVEMENT CORES AND SOIL BORINGS  
LPC 663 CCDD CERTIFICATION

NOT FOR BID

PAVEMENT CORE MEASUREMENT LOG  
STREETS PROGRAM  
VILLA PARK, ILLINOIS

<b>Core No. B-1</b>						
<b>Location</b>	N. Harvard Avenue ~130' N of Wildfire					
<b>Material</b>	<b>Depth (in.)</b>	<b>Thickness (in.)</b>	<b>Remarks/Condition</b>	<b>coeff</b>	<b>sn</b>	
Bituminous Surface	0 to 2- 1/2	2- 1/2		0.30	0.75	
PC Concrete	2- 1/2 to 9	6- 1/2		0.50	3.25	
Subgrade	9		See Boring Log B-1			<b>4.00</b>
<b>Core No. B-2</b>						
<b>Location</b>	N. Harvard Avenue ~130' S of Wildfire					
<b>Material</b>	<b>Depth (in.)</b>	<b>Thickness (in.)</b>	<b>Remarks/ Condition</b>	<b>coeff</b>	<b>sn</b>	
Bituminous Surface	0 to 2- 1/2	2- 1/2		0.30	0.75	
Bituminous Binder / BBC	2- 1/2 to 11	8- 1/2		0.25	2.13	
Granular Base	11 to 17	6	Crushed Limestone, CA-06	0.11	0.66	
Subgrade	17		See Boring Log B-2			<b>3.54</b>
<b>Core No. B-3</b>						
<b>Location</b>	W. Monroe Street ~250' E of Harrison					
<b>Material</b>	<b>Depth (in.)</b>	<b>Thickness (in.)</b>	<b>Remarks/Condition</b>	<b>coeff</b>	<b>sn</b>	
Bituminous Surface	0 to 2- 1/2	2- 1/2		0.30	0.75	
PC Concrete	2- 1/2 to 9- 1/2	7		0.50	3.50	
Subgrade	9- 1/2		See Boring Log B-3			<b>4.25</b>
<b>Core No. B-4</b>						
<b>Location</b>	W. Monroe Street ~430' E of Yale					
<b>Material</b>	<b>Depth (in.)</b>	<b>Thickness (in.)</b>	<b>Remarks/Condition</b>	<b>coeff</b>	<b>sn</b>	
Bituminous Surface	0 to 2	2		0.30	0.60	
PC Concrete	2 to 8- 3/4	6- 3/4		0.50	3.38	
Subgrade	8- 3/4		See Boring Log B-4			<b>3.98</b>
<b>Core No. B-5</b>						
<b>Location</b>	W. Monroe Street ~225' E of Ardmore					
<b>Material</b>	<b>Depth (in.)</b>	<b>Thickness (in.)</b>	<b>Remarks/Condition</b>	<b>coeff</b>	<b>sn</b>	
Bituminous Surface	0 to 2- 1/2	2- 1/2		0.30	0.75	
PC Concrete	2- 1/2 to 9	6- 1/2		0.50	3.25	
Subgrade	9		See Boring Log B-5			<b>4.00</b>

PROJECT: **Streets Program**

SITE LOCATION: **Villa Park, Illinois**

BORING LOCATION: **N. Harvard Ave, 130' N of Wildfire**

CLIENT: **Civiltech Engineering, Inc.**

DEPTH (feet)	SOIL TYPE	Material Description	Elevation	SAMPLE			TESTS			REMARKS
				TYPE/INTERVAL	NO.	N-VALUE Blows per ft.	Wc%	Dry Unit Weight, pcf	Unconfined Compressive Strength, tsf	
0		PAVEMENT - 2-1/2" Bit. Concrete over 6-1/2" PC Concrete	0.0							
		FILL - Grey Crushed Limestone, slightly dense to very loose	-0.8	SS	1	7	8			
2.5										
				SS	2	2	10			
5										
				SS	3	2	9			
7.5										
				SS	4	1	10			
10		End of Boring at 10'	-10.0							

WATER LEVEL OBSERVATIONS, ft.  
 DURING DRILLING: none  
 IMMEDIATELY AFTER DRILLING: dry  
 DELAYED READING AFTER



BORING STARTED: 10/15/15  
 BORING COMPLETED: 10/15/15  
 LOGGED BY: GPF  
 BORING METHOD: HSA

PROJECT: Streets Program

SITE LOCATION: Villa Park, Illinois

BORING LOCATION: N. Harvard Ave, 130' S of Wildfire

CLIENT: Civiltech Engineering, Inc.

DEPTH (feet)	SOIL TYPE	Material Description	Elevation	SAMPLE			TESTS			REMARKS
				TYPE/INTERVAL	NO.	N-VALUE Blows per ft.	Wc%	Dry Unit Weight, pcf	Unconfined Compressive Strength, tsf	
0		PAVEMENT - 11" Bit. Concrete over 6" Crushed Limestone	0.0							
2.5		FILL - Brown and Grey, some Black Silty CLAY, trace Sand, CL, very stiff	-1.4	SS	1	7	19	106	3.59	
5		Brown and Grey Silty CLAY, trace Sand, trace Gravel, CL, very stiff	-3.0	SS	2	7	25	79	2.72	
7.5				SS	3	5	26	97	2.25	
10				SS	4	4	18	108	2.33	
		End of Boring at 10'	-10.0							

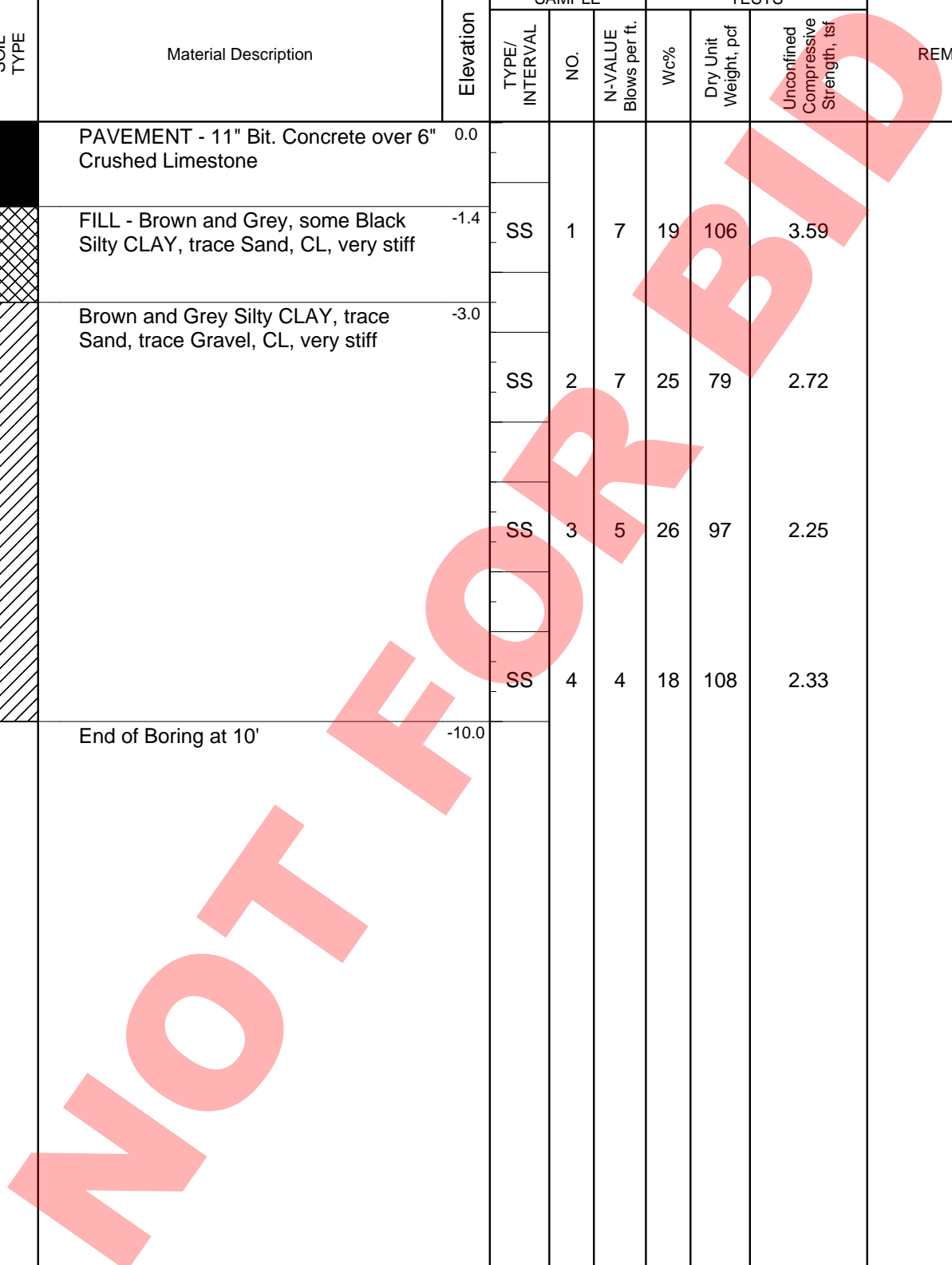

WATER LEVEL OBSERVATIONS, ft.  
 DURING DRILLING: none  
 IMMEDIATELY AFTER DRILLING: dry  
 DELAYED READING AFTER



BORING STARTED: 10/15/15  
 BORING COMPLETED: 10/15/15  
 LOGGED BY: GPF  
 BORING METHOD: HSA

**PAVEMENT CORE MEASUREMENT LOG**  
**2017 STREET IMPROVEMENT PROGRAM**  
**VILLA PARK, ILLINOIS**

<b>Core No. C-1</b>								
<b>Location</b>	North Harvard Avenue; SB Lane ~ 350' North of Wildfire Drive							
<b>Material</b>	<b>Depth (in.)</b>	<b>Thickness (in.)</b>	<b>Remarks/Condition</b>				<b>coeff</b>	<b>sn</b>
Bituminous Surface	0 to 2- 1/2	2- 1/2	Fair, Minor Voids				0.30	0.75
Bituminous Surface	2- 1/2 to 4	1- 1/2	Fair, Minor Voids				0.23	0.35
Bit. Binder/BBC	4 to 6- 1/4	2- 1/4	Fair, Minor Voids				0.20	0.45
Bit. Binder/BBC	6- 1/4 to 11- 1/2	5- 1/4	Fair, Minor Voids				0.20	1.05
Base Course	11- 1/2 to 20- 3/4	9- 1/4	Grey fractured LIMESTONE				0.09	0.83
Subgrade	20- 3/4+		Brown and Grey CLAY, A-6 MC=22%, IBV=6, Qu=1.92 tsf					<b>3.43</b>
<b>Core No. C-2</b>								
<b>Location</b>	West Ridge Road; WB Lane ~ 150' East of North Iowa Avenue							
<b>Material</b>	<b>Depth (in.)</b>	<b>Thickness (in.)</b>	<b>Remarks/ Condition</b>					
PC Concrete	0 to 7- 1/2	7- 1/2	Core Intact					
Subgrade	7- 1/2+		See Boring Log					
<b>Core No. C-3</b>								
<b>Location</b>	West Ridge Road; EB Lane ~ 155' East of North Michigan Avenue							
<b>Material</b>	<b>Depth (in.)</b>	<b>Thickness (in.)</b>	<b>Remarks/Condition</b>					
PC Concrete	0 to 7- 1/4	7- 1/4	Core Intact					
Subgrade	7 -1/4+		Gr Clayey SAND and GRAVEL, A-2-4 MC=15%, IBV=22, Qu=7.04 tsf					
<b>Core No. C-4</b>								
<b>Location</b>	West Sunset Drive; WB Lane ~ 190' East of North Addison Road							
<b>Material</b>	<b>Depth (in.)</b>	<b>Thickness (in.)</b>	<b>Remarks/Condition</b>					
PC Concrete	0 to 6- 1/4	6- 1/4	Core Intact					
Subgrade	6- 1/4+		Grey CLAY, A-6 MC=23%, IBV=6, QU=1.92 tsf					
<b>Core No. C-5</b>								
<b>Location</b>	West Sunset Drive; EB Lane ~ 165' East of North Wisconsin Avenue							
<b>Material</b>	<b>Depth (in.)</b>	<b>Thickness (in.)</b>	<b>Remarks/Condition</b>					
PC Concrete	0 to 6- 1/4	6- 1/4	Core Intact					
Subgrade	6- 1/4+		Black and Dark Grey CLAY, A-7-6 MC=33%, IBV=4, Qu=1.28 tsf					
<b>Core No. C-6</b>								
<b>Location</b>	West Sunset Drive; WB Lane ~ 165' West of North Yale Avenue							
<b>Material</b>	<b>Depth (in.)</b>	<b>Thickness (in.)</b>	<b>Remarks/Condition</b>					
PC Concrete	0 to 6	6	Core Intact					
Subgrade	6+		See Boring Log					

**PAVEMENT CORE MEASUREMENT LOG**  
**2017 STREET IMPROVEMENT PROGRAM**  
**VILLA PARK, ILLINOIS**

<b>Core No. C-7</b>						
<b>Location</b>		West Adams Street; WB Lane ~ 230' East of South Addison Avenue				
<b>Material</b>	<b>Depth (in.)</b>	<b>Thickness (in.)</b>	<b>Remarks/Condition</b>			
Bituminous Surface	0 to 2	2	Fair, Minor Voids			
PC Concrete	2 to 9- 1/2	7- 1/2	Horizontal Crack Mid-Depth			
Subgrade	9- 1/2+		See Boring Log			
<b>Core No. C-8</b>						
<b>Location</b>		West Adams Street; EB Lane ~ 235' East of South Michigan Avenue				
<b>Material</b>	<b>Depth (in.)</b>	<b>Thickness (in.)</b>	<b>Remarks/Condition</b>			
Bituminous Surface	0 to 2	2	Fair, Minor Voids			
PC Concrete	2 to 8- 3/4	6- 3/4	Horizontal Crack Bottom Third			
Subgrade	8- 3/4+		See Boring Log			
<b>Core No. C-9</b>						
<b>Location</b>		West Adams Street; WB Lane ~ 375' East of South Yale Avenue				
<b>Material</b>	<b>Depth (in.)</b>	<b>Thickness (in.)</b>	<b>Remarks/Condition</b>			
Bituminous Surface	0 to 1- 1/4	1- 1/4	Fair, Minor Voids			
PC Concrete	1- 1/4 to 8	6- 3/4	Core Intact			
Subgrade	8+		See Boring Log			
<b>Core No. C-10</b>						
<b>Location</b>		Grant Avenue; NB Lane ~ 345' South of East Monroe Street				
<b>Material</b>	<b>Depth (in.)</b>	<b>Thickness (in.)</b>	<b>Remarks/Condition</b>	<b>coeff</b>	<b>sn</b>	
Bituminous Surface	0 to 1- 3/4	1- 3/4	Minor Voids, Crack Fabric at Bottom	0.30	0.53	
Bituminous Surface	1- 3/4 to 3- 3/4	2	Fair, Minor Voids	0.23	0.46	
Base Course	3- 3/4 to 13	9- 1/4	Grey Crushed LIMESTONE	0.10	0.93	
Subgrade	13+		See Boring Log		<b>1.91</b>	
<b>Core No. C-11</b>						
<b>Location</b>		Grant Avenue; SB Lane ~ 175' South of Frank Street				
<b>Material</b>	<b>Depth (in.)</b>	<b>Thickness (in.)</b>	<b>Remarks/ Condition</b>	<b>coeff</b>	<b>sn</b>	
Bituminous Surface	0 to 1- 1/4	1- 1/4	Minor Voids, Crack Fabric at Bottom	0.30	0.38	
Bituminous Surface	1- 1/4 to 3- 3/4	2- 1/2	Fair, Minor Voids	0.23	0.58	
Base Course	3- 3/4 to 10- 3/4	7	Grey Crushed LIMESTONE	0.10	0.70	
Subgrade	10- 3/4+		See Boring Log		<b>1.65</b>	
<b>Core No. C-12</b>						
<b>Location</b>		Cross Street; NB Lane ~ 90' North of Julia Drive				
<b>Material</b>	<b>Depth (in.)</b>	<b>Thickness (in.)</b>	<b>Remarks/ Condition</b>	<b>coeff</b>	<b>sn</b>	
Bituminous Surface	0 to 1- 1/2	1- 1/2	Minor Voids, Crack Fabric at Bottom	0.30	0.45	
Bituminous Surface	1- 1/2 to 3- 1/2	2	Fair, Minor Voids	0.23	0.46	
Base Course	3- 1/2 to 13- 1/4	9- 3/4	Dark Brown Crushed LIMESTONE	0.10	0.98	
Subgrade	13- 1/4+		See Boring Log		<b>1.89</b>	



PROJECT: **2017 Street Program, Villa Park**

SITE LOCATION: **Villa Park, IL**

BORING LOCATION: **W. Ridge Road**

CLIENT: **Civiltech Engineering, Inc.**

DEPTH (feet)	SOIL TYPE	Material Description	Elevation	SAMPLE			TESTS			REMARKS
				TYPE/INTERVAL	NO.	N-VALUE Blows per ft.	Wc%	Dry Unit Weight, pcf	Unconfined Compressive Strength, tsf	
0		PC Concrete Pavement, 7-1/2"	0.0							
		Brown and Grey CLAY, A-6 very stiff to hard	-0.6	SS	1	6	19	100	2.41	
2.5										
				SS	2	16	19	105	4.27	
5										
				SS	3	22	18	105	7.84	
7.5		Grey CLAY, A-6 hard	-7.3							
				SS	4	19	17	110	4.19	
10		End of Boring at 10 Feet	-10.0							

WATER LEVEL OBSERVATIONS, ft.  
 DURING DRILLING:  None  
 IMMEDIATELY AFTER DRILLING:  Dry  
 DELAYED READING AFTER 



BORING STARTED: 12/5/16  
 BORING COMPLETED: 12/5/16  
 LOGGED BY: MP  
 BORING METHOD: CFA

PROJECT: **2017 Street Program, Villa Park**

SITE LOCATION: **Villa Park, IL**

BORING LOCATION: **W. Sunset Drive**

CLIENT: **Civiltech Engineering, Inc.**



DEPTH (feet)	SOIL TYPE	Material Description	Elevation	SAMPLE			TESTS			REMARKS
				TYPE/ INTERVAL	NO.	N-VALUE Blows per ft.	Wc%	Dry Unit Weight, pcf	Unconfined Compressive Strength, tsf	
0		PC Concrete Pavement, 6 inches	0.0							
2.5		Dark Grey, Brown & Grey CLAY, A-7-6(56) stiff to firm	-0.5	SS	1	5	29	85	1.47	
5		to very stiff		SS	2	4	32	85	0.47	
7.5				SS	3	7	26	97	2.68	
		Grey CLAY, A-6 very stiff	-8.0							
10		End of Boring at 10 Feet	-10.0	SS	4	14	17	107	3.69	

WATER LEVEL OBSERVATIONS, ft.

DURING DRILLING:

IMMEDIATELY AFTER DRILLING:

DELAYED READING AFTER

 None  
 Dry



**MSET**

**BORING STARTED:** 12/5/16

**BORING COMPLETED:** 12/5/16

**LOGGED BY:** MP

**BORING METHOD:** CFA

PROJECT: **2017 Street Program, Villa Park**

SITE LOCATION: **Villa Park, IL**

BORING LOCATION: **W. Adams Street**

CLIENT: **Civiltech Engineering, Inc.**

DEPTH (feet)	SOIL TYPE	Material Description	Elevation	SAMPLE			TESTS			REMARKS
				TYPE/INTERVAL	NO.	N-VALUE Blows per ft.	Wc%	Dry Unit Weight, pcf	Unconfined Compressive Strength, tsf	
0		Bituminous Concrete 2"	0.0							
		PC Concrete 7-1/2"	-0.2							
		Brown and Grey CLAY, A-6 stiff to hard	-0.8	SS	1	5	22	94	1.55	
2.5		fine sand seam at 2.5'								
				SS	2	10	16	112	5.15	
				SS	3	10	18	108	4.62	
7.5		Grey CLAY, A-6 hard	-8.0							
				SS	4	17	15	112	6.44	
10		End of Boring at 10 Feet	-10.0							

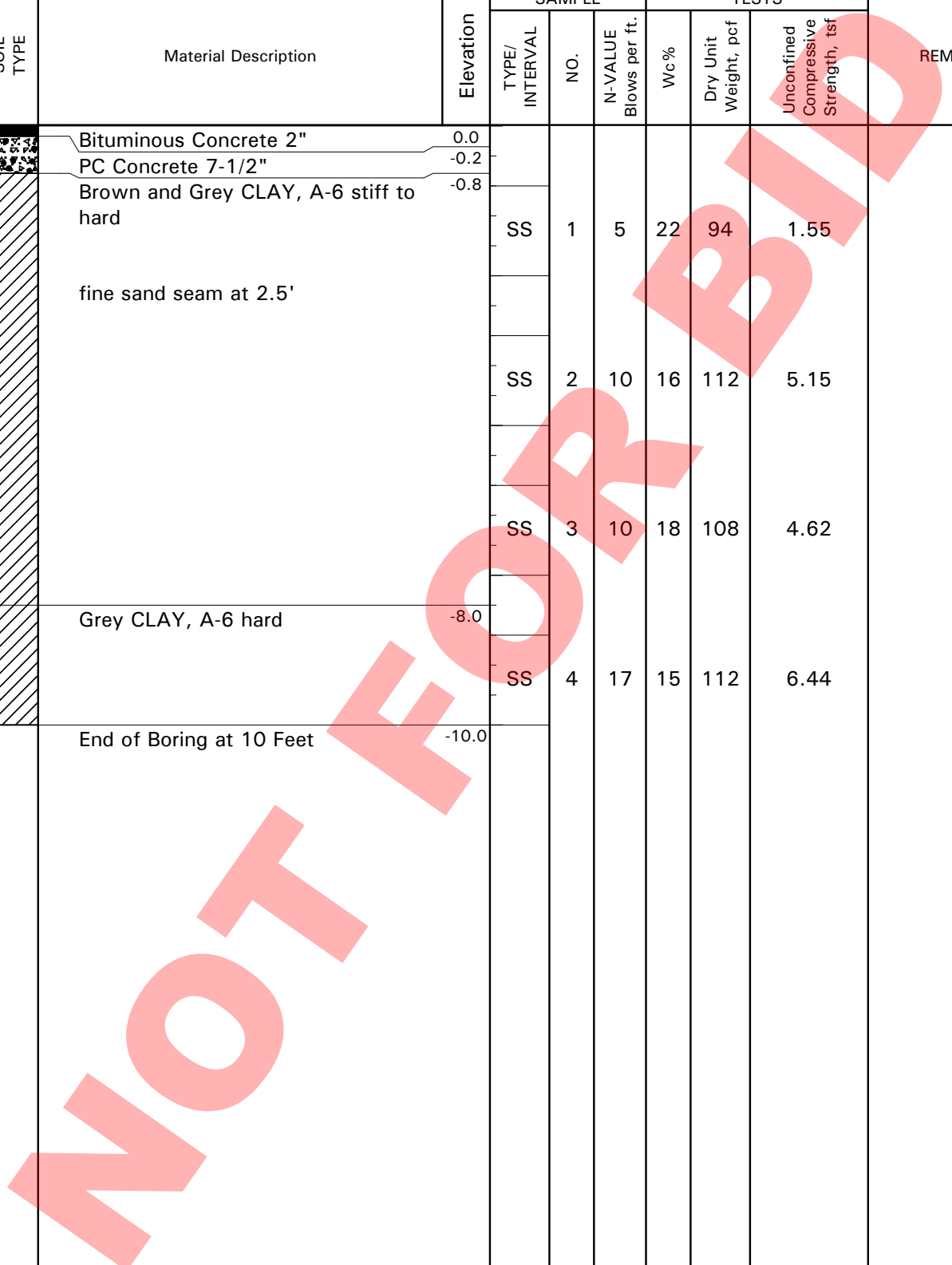

WATER LEVEL OBSERVATIONS, ft.  
 DURING DRILLING: None  
 IMMEDIATELY AFTER DRILLING: Dry  
 DELAYED READING AFTER



BORING STARTED: 12/5/16  
 BORING COMPLETED: 12/5/16  
 LOGGED BY: MP  
 BORING METHOD: CFA

PROJECT: **2017 Street Program, Villa Park**

SITE LOCATION: **Villa Park, IL**

BORING LOCATION: **W. Adams Street**

CLIENT: **Civiltech Engineering, Inc.**

DEPTH (feet)	SOIL TYPE	Material Description	Elevation	SAMPLE			TESTS			REMARKS
				TYPE/INTERVAL	NO.	N-VALUE Blows per ft.	Wc%	Dry Unit Weight, pcf	Unconfined Compressive Strength, tsf	
0		Bituminous Concrete 2"	0.0							
		PC Concrete, 6-3/4"	-0.2							
		Brown and Grey CLAY, A-6 hard to very stiff	-0.7	SS	1	9	18	105	3.30	
2.5										
				SS	2	7	20	103	2.48	
5										
				SS	3	17	17	109	5.43	
7.5										
		Brown Grey CLAY, A-6 hard	-8.5	SS	4	19	16	113	6.52	
10		End of Boring at 10 Feet	-10.0							

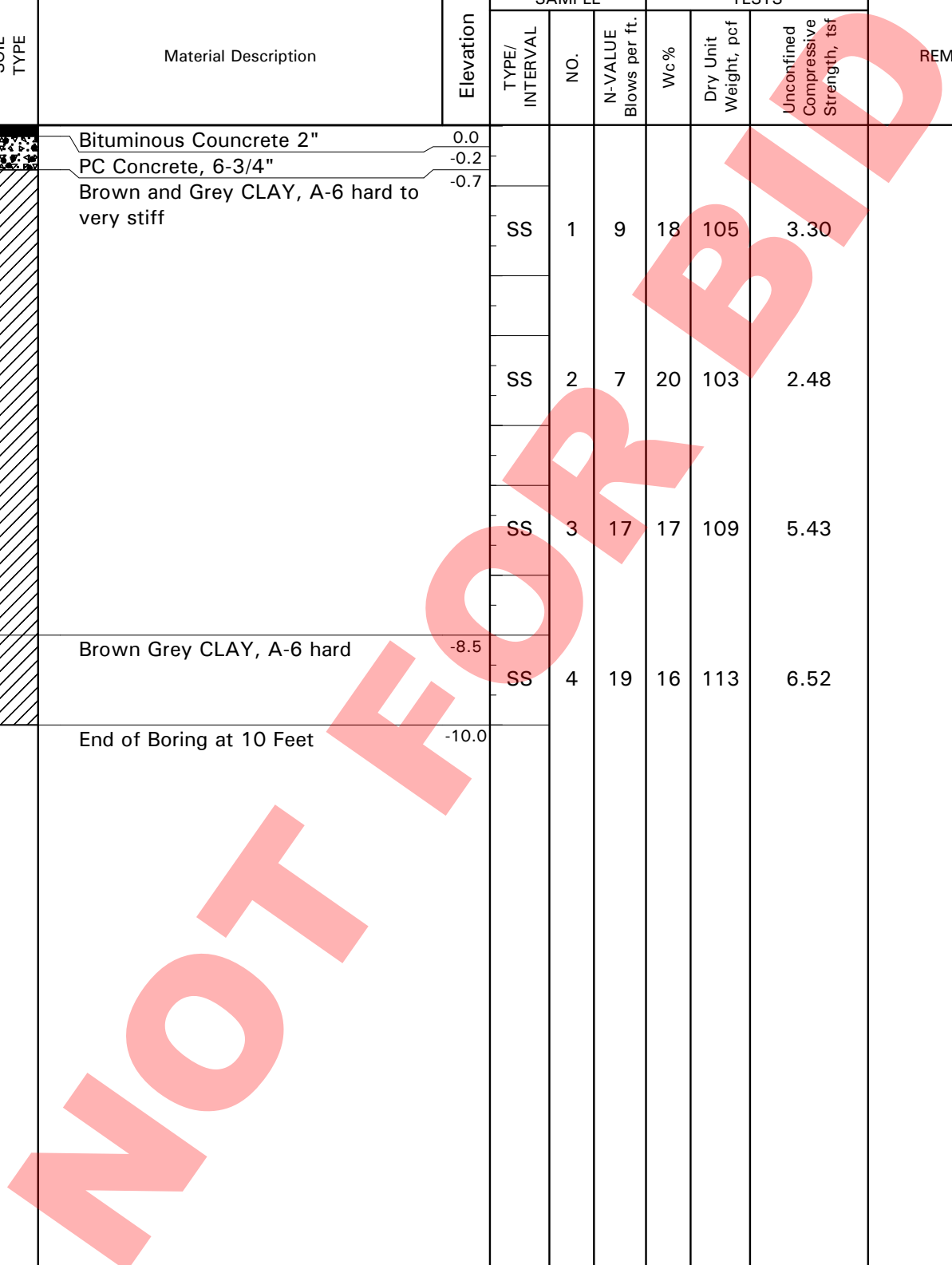

WATER LEVEL OBSERVATIONS, ft.  
 DURING DRILLING: None  
 IMMEDIATELY AFTER DRILLING: Dry  
 DELAYED READING AFTER



BORING STARTED: 12/5/16  
 BORING COMPLETED: 12/5/16  
 LOGGED BY: MP  
 BORING METHOD: CFA

PROJECT: **2017 Street Program, Villa Park**

SITE LOCATION: **Villa Park, IL**

BORING LOCATION: **W. Adams Street**

CLIENT: **Civiltech Engineering, Inc.**

DEPTH (feet)	SOIL TYPE	Material Description	Elevation	SAMPLE			TESTS			REMARKS
				TYPE/INTERVAL	NO.	N-VALUE Blows per ft.	Wc%	Dry Unit Weight, pcf	Unconfined Compressive Strength, tsf	
0		Bituminous Concrete, 1-1/4"	0.0							
		PC Concrete, 6-3/4"	-0.1							
		Brown and Grey CLAY, A-6 hard to very stiff	-0.7	SS	1	7	21	96	2.48	
2.5										
				SS	2	7	18	106	4.00	
5										
				SS	3	15	17	112	3.69	
7.5										
		Grey CLAY, A-6 stiff	-8.0							
				SS	4	10	17	110	1.67	
10		End of Boring at 10 Feet	-10.0							

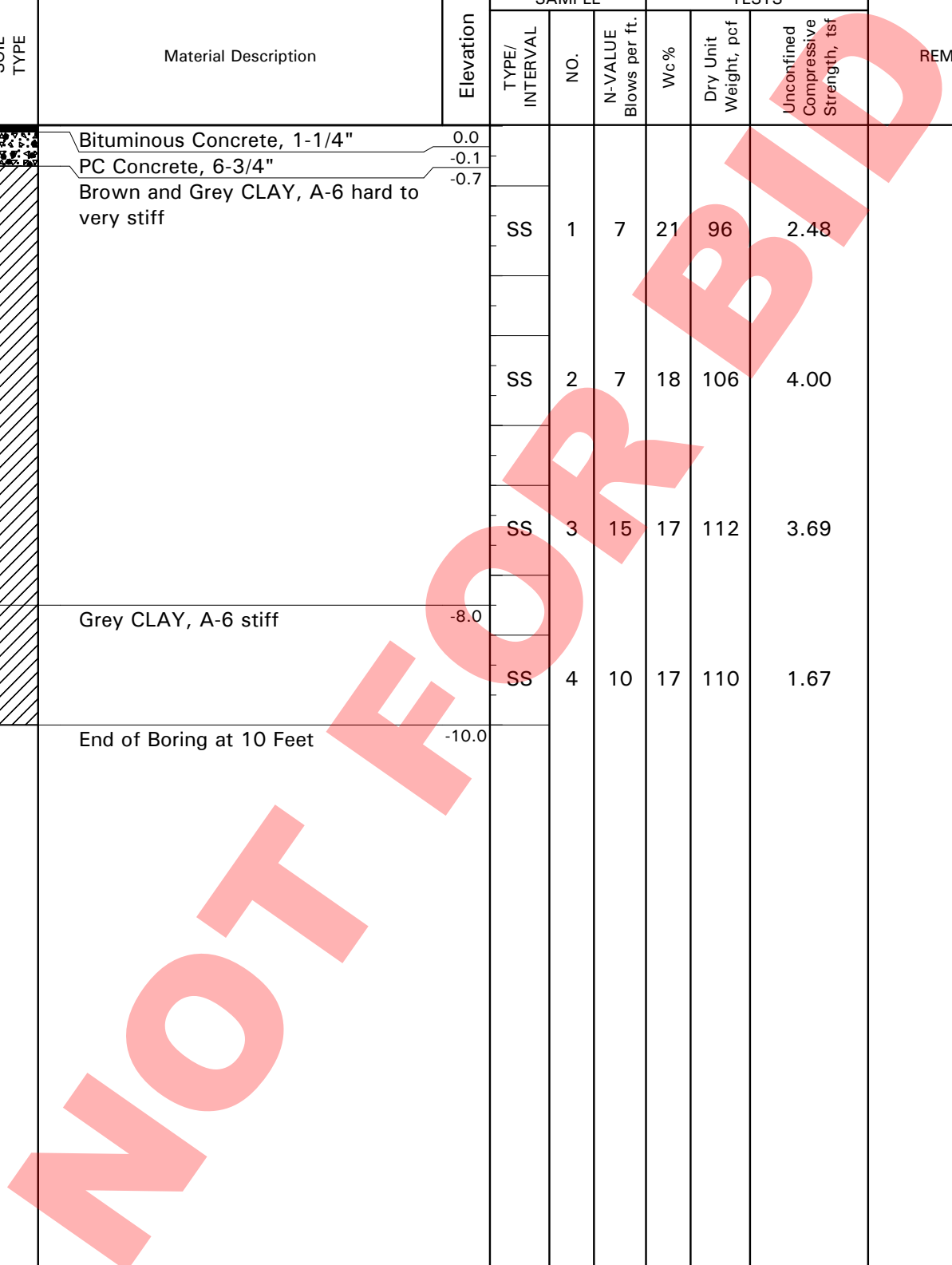

WATER LEVEL OBSERVATIONS, ft.  
 DURING DRILLING: None  
 IMMEDIATELY AFTER DRILLING: Dry  
 DELAYED READING AFTER



BORING STARTED: 12/5/16  
 BORING COMPLETED: 12/5/16  
 LOGGED BY: MP  
 BORING METHOD: CFA

PROJECT: **2017 Street Program, Villa Park**

SITE LOCATION: **Villa Park, IL**

BORING LOCATION: **Grant Avenue**

CLIENT: **Civiltech Engineering, Inc.**

DEPTH (feet)	SOIL TYPE	Material Description	Elevation	SAMPLE			TESTS			REMARKS
				TYPE/INTERVAL	NO.	N-VALUE Blows per ft.	Wc%	Dry Unit Weight, pcf	Unconfined Compressive Strength, tsf	
0		Bituminous Concrete, 3-3/4"	0.0							
		Grey Crushed Limestone, CA-06	-0.3							
2.5		Brown and Grey CLAY, A-6, hard to very stiff	-1.1	SS	1	12	18	109	4.58	
5				SS	2	10	19	107	2.83	
7.5				SS	3	17	22	104	5.04	
		Grey CLAY, A-6 very stiff	-8.0							
10		End of Boring at 10 Feet	-10.0	SS	4	10	21	100	3.22	

WATER LEVEL OBSERVATIONS, ft.

DURING DRILLING:

IMMEDIATELY AFTER DRILLING:

DELAYED READING AFTER

None
   
Dry



**MSET**

BORING STARTED: 12/5/16

BORING COMPLETED: 12/5/16

LOGGED BY: MP

BORING METHOD: CFA

PROJECT: **2017 Street Program, Villa Park**

SITE LOCATION: **Villa Park, IL**

BORING LOCATION: **Grant Avenue**

CLIENT: **Civiltech Engineering, Inc.**



DEPTH (feet)	SOIL TYPE	Material Description	Elevation	SAMPLE			TESTS			REMARKS
				TYPE/ INTERVAL	NO.	N-VALUE Blows per ft.	Wc%	Dry Unit Weight, pcf	Unconfined Compressive Strength, tsf	
0		Bituminous Concrete, 3-3/4"	0.0							
		Grey Crushed Limestone, CA-06	-0.3							
		Black CLAY, A-7-6(28) very stiff	-0.9	SS	1	10	24	91	3.03	
2.5		Olive Grey CLAY, A-7-6 firm	-3.0							
				SS	2	3	41	71	0.78	
5										
				SS	3	3	38	77	0.66	
7.5		Grey CLAY, A-6 stiff intermittent sand seams at 9'	-8.0							
				SS	4	7	14	120	1.09	
10		End of Boring at 10 Feet	-10.0							

WATER LEVEL OBSERVATIONS, ft.

DURING DRILLING:

IMMEDIATELY AFTER DRILLING:

DELAYED READING AFTER

 None  
 Dry



**MSET**

BORING STARTED: 12/5/16

BORING COMPLETED: 12/5/16

LOGGED BY: MP

BORING METHOD: CFA

PROJECT: **2017 Street Program, Villa Park**



SITE LOCATION: **Villa Park, IL**

BORING LOCATION: **Cross Street**

CLIENT: **Civiltech Engineering, Inc.**

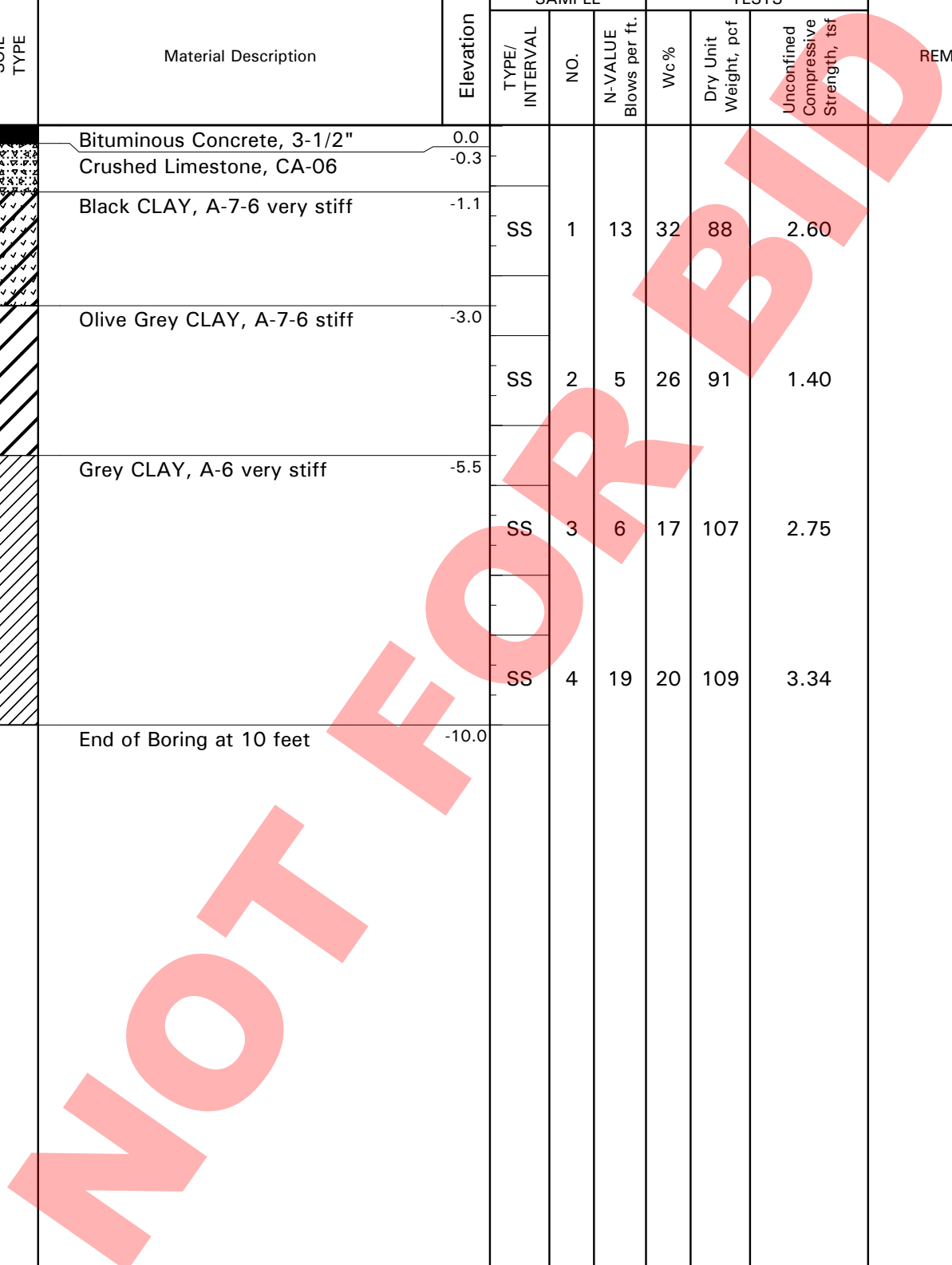
DEPTH (feet)	SOIL TYPE	Material Description	Elevation	SAMPLE			TESTS			REMARKS
				TYPE/ INTERVAL	NO.	N-VALUE Blows per ft.	Wc%	Dry Unit Weight, pcf	Unconfined Compressive Strength, tsf	
0		Bituminous Concrete, 3-1/2"	0.0							
		Crushed Limestone, CA-06	-0.3							
		Black CLAY, A-7-6 very stiff	-1.1	SS	1	13	32	88	2.60	
2.5		Olive Grey CLAY, A-7-6 stiff	-3.0							
				SS	2	5	26	91	1.40	
5		Grey CLAY, A-6 very stiff	-5.5							
				SS	3	6	17	107	2.75	
7.5										
				SS	4	19	20	109	3.34	
10		End of Boring at 10 feet	-10.0							



WATER LEVEL OBSERVATIONS, ft.  
 DURING DRILLING:  None  
 IMMEDIATELY AFTER DRILLING:  Dry  
 DELAYED READING AFTER 



BORING STARTED: 12/5/16  
 BORING COMPLETED: 12/5/16  
 LOGGED BY: MP  
 BORING METHOD: CFA



# Illinois Environmental Protection Agency

Bureau of Land • 1021 North Grand Avenue East • P.O. Box 19276 • Springfield • Illinois • 62794-9276

## Uncontaminated Soil Certification by Licensed Professional Engineer or Licensed Professional Geologist for Use of Uncontaminated Soil as Fill in a CCDD or Uncontaminated Soil Fill Operation LPC-663

Revised in accordance with 35 Ill. Adm. Code 1100, as amended by PCB R2012-009 (eff. Aug. 27, 2012)

This certification form is to be used by professional engineers and professional geologists to certify, pursuant to 35 Ill. Adm. Code 1100.205(a)(1)(B), that soil (i) is uncontaminated soil and (ii) is within a pH range of 6.26 to 9.0. If you have questions about this form, please telephone the Bureau of Land Permit Section at 217/524-3300.

This form may be completed online, saved locally, printed and signed, and submitted to prospective clean construction or demolition debris (CCDD) fill operations or uncontaminated soil fill operations.

### I. Source Location Information

(Describe the location of the source of the uncontaminated soil)

Project Name: CCDD Soil Assessment Office Phone Number, if available: \_\_\_\_\_

Physical Site Location (address, including number and street):

Portions of S. Harvard Avenue, W. Ridge Avenue, W. Sunset Drive, W. Adams Street & S. Grant Avenue - See Attached Figure

City: Villa Park State: IL Zip Code: 60181

County: DuPage Township: York

Lat/Long of approximate center of site in decimal degrees (DD.ddddd) to five decimal places (e.g., 40.67890, -90.12345):

Latitude: 41.884351 Longitude: -87.976815

(Decimal Degrees) (-Decimal Degrees)

Identify how the lat/long data were determined:

GPS  Map Interpolation  Photo Interpolation  Survey  Other

IEPA Site Number(s), if assigned: BOL: \_\_\_\_\_ BOW: \_\_\_\_\_ BOA: \_\_\_\_\_

### II. Owner/Operator Information for Source Site

Site Owner

Site Operator

Name: Village of Villa Park

Name: \_\_\_\_\_

Street Address: 20 South Ardmore Avenue

Street Address: \_\_\_\_\_

PO Box: \_\_\_\_\_

PO Box: \_\_\_\_\_

City: Villa Park State: IL

City: \_\_\_\_\_ State: \_\_\_\_\_

Zip Code: 60181 Phone: 630-834-8500

Zip Code: \_\_\_\_\_ Phone: \_\_\_\_\_

Contact: \_\_\_\_\_

Contact: \_\_\_\_\_

Email, if available: \_\_\_\_\_

Email, if available: \_\_\_\_\_

This Agency is authorized to require this information under Section 4 and Title X of the Environmental Protection Act (415 ILCS 5/4, 5/39). Failure to disclose this information may result in: a civil penalty of not to exceed \$50,000 for the violation and an additional civil penalty of not to exceed \$10,000 for each day during which the violation continues (415 ILCS 5/42). This form has been approved by the Forms Management Center.

Project Name: CCDD Soil Assessment

Latitude: 41.884351 Longitude: -87.976815

Uncontaminated Site Certification

**III. Basis for Certification and Attachments**

For each item listed below, reference the attachments to this form that provide the required information.

- a. A Description of the soil sample points and how they were determined to be sufficient in number and appropriately located 35 Ill. Adm. Code 1100.610(a)]:

A limited historical & regulatory review was performed to identify PIPs. Site reconnaissance was performed while sampling to evaluate on-site environmental conditions & potential PIPs. Based on the nature & scope of the project, 15 samples were collected for indicator contaminants associated with identified PIPs and screened with a PID. Figures show sample locations.

- b. Analytical soil testing results to show that soil chemical constituents comply with the maximum allowable concentrations established pursuant to 35 Ill. Adm. Code Part 1100, Subpart F and that the soil pH is within the range of 6.25 to 9.0, including the documentation of chain of custody control, a copy of the lab analysis; the accreditation status of the laboratory performing the analysis; and certification by an authorized agent of the laboratory that the analysis has been performed in accordance with the Agency's rules for the accreditation of environmental and the scope of the accreditation [35 Ill. Adm. Code 1100.201(g), 1100.205(a), 1100.610]:

See attached analytical summary tables, laboratory reports and associated NELAC certification. Figure 2 and 3 identifies the project area that is covered by this certification.

**IV. Certification Statement, Signature and Seal of Licensed Professional Engineer or Licensed Professional Geologist**

I, Ryan M. LaDieu, P.E. (name of licensed professional engineer or geologist) certify under penalty of law that the information submitted, including but not limited to, all attachments and other information, is to the best of my knowledge and belief, true, accurate and complete. In accordance with the Environmental Protection Act [415 ILCS 5/22.51 or 22.51a] and 35 Ill. Adm. Code 1100.205(a), I certify that the soil from this site is uncontaminated soil. I also certify that the soil pH is within the range of 6.25 to 9.0. In addition, I certify that the soil has not been removed from the site as part of a cleanup or removal of contaminants. All necessary documentation is attached.

**Any person who knowingly makes a false, fictitious, or fraudulent material statement, orally or in writing, to the Illinois EPA commits a Class 4 felony. A second or subsequent offense after conviction is a Class 3 felony. (415 ILCS 5/44(h))**

Company Name: True North Consultants

Street Address: 1240 Iroquois Avenue, Suite 206

City: Naperville State: IL Zip Code: 60563

Phone: 630.717.2880

Ryan M. LaDieu

Printed Name:

02 10 17

Date:

Licensed Professional Engineer or  
Licensed Professional Geologist Signature:



P.E. or L.P.G. Seal:

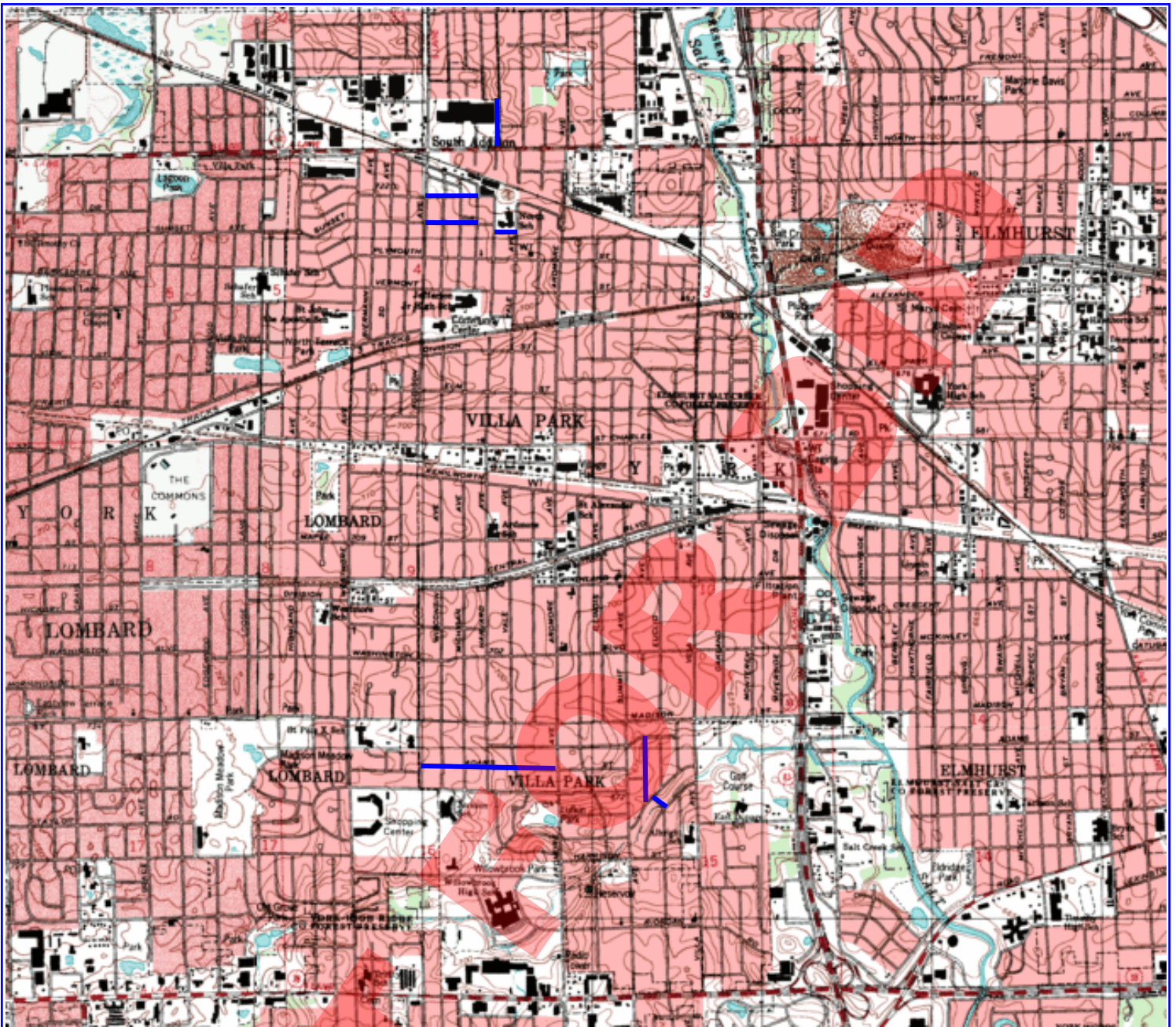

1978 CHICAGO, ILLINOIS — TOPOGRAPHIC MAP ADAPTED FROM MYTOPO

— APPROXIMATE SITE LOCATION

**TRUE NORTH**  
CONSULTANTS

1240 IROQUOIS AVE, SUITE 206  
NAPERVILLE, ILLINOIS 60563

SITE LOCATION	PORTIONS OF SOUTH HARVARD AVENUE, WEST RIDGE ROAD, WEST SUNSET DRIVE, WEST ADAMS STREET AND SOUTH GRANT AVENUE, VILLA PARK, ILLINOIS 60181
CLIENT	VILLAGE OF VILLA PARK 20 S. ARDMORE AVENUE VILLA PARK, IL 60181

NOT TO SCALE

FIGURE	I
PROJECT NUMBER	TII7047
DATE	2/10/2017



2016 — AERIAL PHOTOGRAPH ADAPTED FROM GOOGLE MAPS

 APPROXIMATE LOCATION OF SOIL SAMPLE BORING 12/5/2016 FOR CIVILTECH ENGINEERING

 APPROXIMATE LOCATION OF SOILS THAT MUST BE EXCLUDED FROM CCDD MANAGEMENT

**TRUENORTH**  
CONSULTANTS

1240 IROQUOIS AVE, SUITE 206  
NAPERVILLE, ILLINOIS 60563

SITE LOCATION	PORTIONS OF SOUTH HARVARD AVENUE, WEST RIDGE ROAD, WEST SUNSET DRIVE, WEST ADAMS STREET AND SOUTH GRANT AVENUE, VILLA PARK, ILLINOIS 60181
CLIENT	VILLAGE OF VILLA PARK 20 S. ARDMORE AVENUE VILLA PARK, IL 60181



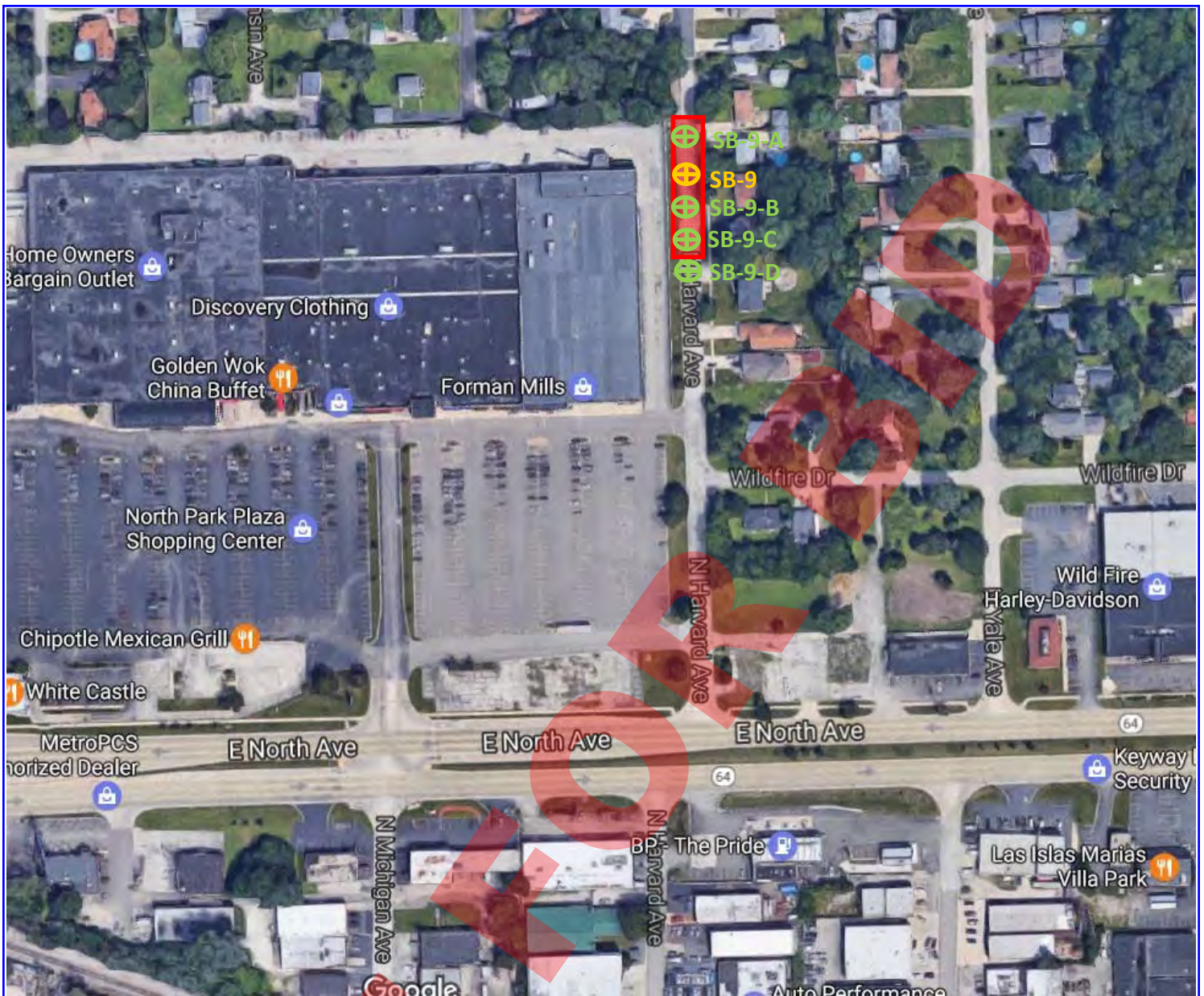

NOT TO SCALE

FIGURE	2
PROJECT NUMBER	TII7047
DATE	2/10/2017



2017 — AERIAL PHOTOGRAPH ADAPTED FROM GOOGLE MAPS

-  APPROXIMATE LOCATION OF SOIL SAMPLE 2/1/2017
-  APPROXIMATE LOCATION OF SOIL SAMPLE 12/5/2016
-  APPROXIMATE LOCATION OF SOILS THAT MUST BE EXCLUDED FROM CDD MANAGEMENT

**TRUE NORTH**  
CONSULTANTS

1240 IROQUOIS AVE, SUITE 206  
NAPERVILLE, ILLINOIS 60563

SITE LOCATION	PORTIONS OF SOUTH HARVARD AVENUE AND SOUTH CROSS STREET VILLA PARK, ILLINOIS 60181
CLIENT	VILLAGE OF VILLA PARK 20 S. ARDMORE AVENUE VILLA PARK, IL 60181



NOT TO SCALE

FIGURE	3
PROJECT NUMBER	TII7047
DATE	2/10/2017



2016 — AERIAL PHOTOGRAPH ADAPTED FROM GOOGLE MAPS



APPROXIMATE LOCATION OF SOIL SAMPLE BORING 12/5/2016 FOR CIVILTECH ENGINEERING



APPROXIMATE LOCATION OF SOILS THAT MUST BE EXCLUDED FROM CCDD MANAGEMENT

**TRUENORTH**  
CONSULTANTS

1240 IROQUOIS AVE, SUITE 206  
NAPERVILLE, ILLINOIS 60563

SITE LOCATION	PORTIONS OF SOUTH HARVARD AVENUE, WEST RIDGE ROAD, WEST SUNSET DRIVE, WEST ADAMS STREET AND SOUTH GRANT AVENUE, VILLA PARK, ILLINOIS 60181
CLIENT	VILLAGE OF VILLA PARK 20 S. ARDMORE AVENUE VILLA PARK, IL 60181





NOT TO SCALE

FIGURE	4
PROJECT NUMBER	TII7047
DATE	2/10/2017



2017 — AERIAL PHOTOGRAPH ADAPTED FROM GOOGLE MAPS

-  APPROXIMATE LOCATION OF SOIL SAMPLE 2/1/2017
-  APPROXIMATE LOCATION OF SOIL SAMPLE 12/5/2016
-  APPROXIMATE LOCATION OF SOILS THAT MUST BE EXCLUDED FROM CCDD MANAGEMENT

**TRUENORTH**  
CONSULTANTS

1240 IROQUOIS AVE, SUITE 206  
NAPERVILLE, ILLINOIS 60563

SITE LOCATION	PORTIONS OF SOUTH HARVARD AVENUE AND SOUTH CROSS STREET VILLA PARK, ILLINOIS 60181
CLIENT	VILLAGE OF VILLA PARK 20 S. ARDMORE AVENUE VILLA PARK, IL 60181



NOT TO SCALE

FIGURE	5
PROJECT NUMBER	TII7047
DATE	2/10/2017

**TABLE I**

**Summary of Soil Analytical Results - Soil Characterization Sampling**

**Benzene, Ethylbenzene, Toluene and total Xylenes (BETX)**

**CLIENT:** Village of Villa Park

**SAMPLE DATE:** December 5, 2016

**SITE:** Portions of Harvard Avenue, Ridge Road, Sunset Drive, Adams Street and Grant Avenue, Villa Park, Illinois 60681

**LABORATORY:** Prairie Analytical Systems, Inc.

**PROJECT NUMBER:** TII6693

**MATRIX:** Soil

**Analytical Method: EPA Method 5035A/8260B**

Contaminant of Concern	Maximum Allowable Concentration (MAC) within a Metropolitan Statistical Area (MSA)		Sample ID	SB-1	SB-2	SB-3	SB-4	SB-5	SB-6	SB-7	SB-8
			Sample Date	12/5/2016	12/5/2016	12/5/2016	12/5/2016	12/5/2016	12/5/2016	12/5/2016	12/5/2016
			Depth	6-7.5'	8.5-10'	8.5-10'	3.5-5'	1-2.5'	3.5-5'	8.5-10'	6-7.5'
	Value	Objective	Soil Type	Silty Clay	Silty Clay	Silty Clay	Silty Clay	Silty Clay	Silty Clay	Silty Clay	Silty Clay
Benzene	<b>0.03</b>	<b>MAC</b>		< 0.00492	NA	< 0.00464	NA	NA	NA	NA	< 0.0125
Ethylbenzene	<b>13</b>	<b>MAC</b>		< 0.00492	NA	< 0.00464	NA	NA	NA	NA	< 0.0125
Toluene	<b>12</b>	<b>MAC</b>		< 0.00492	NA	< 0.00464	NA	NA	NA	NA	< 0.0125
Xylenes (total)	<b>5.6</b>	<b>MAC</b>		< 0.0148	NA	< 0.0139	NA	NA	NA	NA	< 0.0376

**Notes:**

Constituents that are not identified in 35 IAC 1100 Subpart F (MAC Table) are compared to the Metropolitan Statistical Area Background Concentration found in 35 IAC 742 Appendix A, Table H

< = Analyte not detected (i.e. less than RL or MDL)

All data reported in milligrams per kilogram (mg/kg) unless otherwise noted.

NA = This constituent was not analyzed.

NE = No remediation objective established by the IEPA for this constituent.

Bold identifies an exceedence of the referenced objective.



NOT FOR BID

TABLE I cont.

Summary of Soil Analytical Results - Soil Characterization Sampling

Benzene, Ethylbenzene, Toluene and total Xylenes (BETX)

CLIENT: Village of Villa Park

SAMPLE DATE: December 5, 2016

SITE: Portions of Harvard Avenue, Ridge Road, Sunset Drive, Adams Street and Grant Avenue, Villa Park, Illinois 60681

LABORATORY: Prairie Analytical Systems, Inc.

PROJECT NUMBER: TII6693

MATRIX: Soil

Analytical Method: EPA Method 5035A/8260B

Contaminant of Concern	Maximum Allowable Concentration (MAC) within a Metropolitan Statistical Area (MSA)		Sample ID	SB-9						
			Sample Date	12/5/2016						
	Value	Objective	Depth	6-7.5'	Soil Type	Silty Clay				
Benzene	<b>0.03</b>	<b>MAC</b>		< 0.0147						
Ethylbenzene	<b>13</b>	<b>MAC</b>		< 0.0147						
Toluene	<b>12</b>	<b>MAC</b>		< 0.0147						
Xylenes (total)	<b>5.6</b>	<b>MAC</b>		< 0.0440						

Notes:

Constituents that are not identified in 35 IAC 1100 Subpart F (MAC Table) are compared to the Metropolitan Statistical Area Background Concentration found in 35 IAC 742 Appendix A, Table H

< = Analyte not detected (i.e. less than RL or MDL)

All data reported in milligrams per kilogram (mg/kg) unless otherwise noted.

NA = This constituent was not analyzed.

NE = No remediation objective established by the IEPA for this constituent.

Bold identifies an exceedence of the referenced objective.



NOT FOR BID

**TABLE 2**

**Summary of Soil Analytical Results - Soil Characterization Sampling**

**Polynuclear Aromatic Hydrocarbons (PNAs)**

**CLIENT:** Village of Villa Park

**SAMPLE DATE:** December 5, 2016

**SITE:** Portions of Harvard Avenue, Ridge Road, Sunset Drive, Adams Street and Grant Avenue, Villa Park, Illinois 60681

**LABORATORY:** Prairie Analytical Systems, Inc.

**PROJECT NUMBER:** TII6693

**MATRIX:** Soil

**Analytical Method: EPA Method 8270**

Contaminant of Concern	Maximum Allowable Concentration (MAC) within a Metropolitan Statistical Area (MSA)		Sample ID	SB-1	SB-2	SB-3	SB-4	SB-5	SB-6	SB-7	SB-8
			Sample Date	12/5/2016	12/5/2016	12/5/2016	12/5/2016	12/5/2016	12/5/2016	12/5/2016	12/5/2016
			Depth	6-7.5'	8.5-10'	8.5-10'	3.5-5'	1-2.5'	3.5-5'	8.5-10'	6-7.5'
	Value	Objective	Soil Type	Silty Clay	Silty Clay	Silty Clay	Silty Clay	Silty Clay	Silty Clay	Silty Clay	Silty Clay
Acenaphthene	<b>570</b>	<b>MAC</b>		< 0.388	NA	< 0.368	NA	NA	NA	NA	< 0.381
Anthracene	<b>12000</b>	<b>MAC</b>		< 0.388	NA	< 0.368	NA	NA	NA	NA	< 0.381
Benzo(a)anthracene	<b>1.8</b>	<b>MAC</b>		< 0.388	NA	< 0.368	NA	NA	NA	NA	< 0.381
Benzo(b)fluoranthene	<b>2.1</b>	<b>MAC</b>		< 0.388	NA	< 0.368	NA	NA	NA	NA	< 0.381
Benzo(k)fluoranthene	<b>9.0</b>	<b>MAC</b>		< 0.388	NA	< 0.368	NA	NA	NA	NA	< 0.381
Benzo(a)pyrene	<b>2.1</b>	<b>MAC</b>		< 0.0700	NA	< 0.0662	NA	NA	NA	NA	< 0.0687
Chrysene	<b>88</b>	<b>MAC</b>		< 0.388	NA	< 0.368	NA	NA	NA	NA	< 0.381
Dibenz(a,h)anthracene	<b>0.42</b>	<b>MAC</b>		< 0.0700	NA	< 0.0662	NA	NA	NA	NA	< 0.0687
Fluoranthene	<b>3100</b>	<b>MAC</b>		< 0.388	NA	< 0.368	NA	NA	NA	NA	< 0.381
Fluorene	<b>560</b>	<b>MAC</b>		< 0.388	NA	< 0.368	NA	NA	NA	NA	< 0.381
Indeno(1,2,3-cd)pyrene	<b>1.6</b>	<b>MAC</b>		< 0.388	NA	< 0.368	NA	NA	NA	NA	< 0.381
Naphthalene	<b>1.8</b>	<b>MAC</b>		< 0.388	NA	< 0.368	NA	NA	NA	NA	< 0.381
Pyrene	<b>2300</b>	<b>MAC</b>		< 0.388	NA	< 0.368	NA	NA	NA	NA	< 0.381

**Notes:**

Constituents that are not identified in 35 IAC 1100 Subpart F (MAC Table) are compared to the Metropolitan Statistical Area Background Concentration found in 35 IAC 742 Appendix A, Table H

< = Analyte not detected (i.e. less than RL or MDL)

All data reported in milligrams per kilogram (mg/kg) unless otherwise noted.

NA = This constituent was not analyzed.

NE = No remediation objective established by the IEPA for this constituent.

Bold identifies an exceedence of the referenced objective.



TABLE 2 cont.

Summary of Soil Analytical Results - Soil Characterization Sampling

Polynuclear Aromatic Hydrocarbons (PNAs)

CLIENT: Village of Villa Park

SAMPLE DATE: December 5, 2016

SITE: Portions of Harvard Avenue, Ridge Road, Sunset Drive, Adams Street and Grant Avenue, Villa Park, Illinois 60681

LABORATORY: Prairie Analytical Systems, Inc.

PROJECT NUMBER: TII6693

MATRIX: Soil

Analytical Method: EPA Method 8270

Contaminant of Concern	Maximum Allowable Concentration (MAC) within a Metropolitan Statistical Area (MSA)		Sample ID	SB-9						
			Sample Date	12/5/2016						
			Depth	6-7.5'						
	Value	Objective	Soil Type	Silty Clay						
Acenaphthene	<b>570</b>	<b>MAC</b>		< 0.407						
Anthracene	<b>12000</b>	<b>MAC</b>		< 0.407						
Benzo(a)anthracene	<b>1.8</b>	<b>MAC</b>		< 0.407						
Benzo(b)fluoranthene	<b>2.1</b>	<b>MAC</b>		< 0.407						
Benzo(k)fluoranthene	<b>9.0</b>	<b>MAC</b>		< 0.407						
Benzo(a)pyrene	<b>2.1</b>	<b>MAC</b>		< 0.0733						
Chrysene	<b>88</b>	<b>MAC</b>		< 0.407						
Dibenz(a,h)anthracene	<b>0.42</b>	<b>MAC</b>		< 0.0733						
Fluoranthene	<b>3100</b>	<b>MAC</b>		< 0.407						
Fluorene	<b>560</b>	<b>MAC</b>		< 0.407						
Indeno(1,2,3-cd)pyrene	<b>1.6</b>	<b>MAC</b>		< 0.407						
Naphthalene	<b>1.8</b>	<b>MAC</b>		< 0.407						
Pyrene	<b>2300</b>	<b>MAC</b>		< 0.407						

Notes:

Constituents that are not identified in 35 IAC 1100 Subpart F (MAC Table) are compared to the Metropolitan Statistical Area Background Concentration found in 35 IAC 742 Appendix A, Table H

< = Analyte not detected (i.e. less than RL or MDL)

All data reported in milligrams per kilogram (mg/kg) unless otherwise noted.

NA = This constituent was not analyzed.

NE = No remediation objective established by the IEPA for this constituent.

Bold identifies an exceedence of the referenced objective.



**TABLE 3**

**Summary of Soil Analytical Results - Soil Characterization Sampling**

**Resource Conservation Recovery Act (RCRA) Metals**

**CLIENT:** Village of Villa Park

**SAMPLE DATE:** December 5, 2016

**SITE:** Portions of Harvard Avenue, Ridge Road, Sunset Drive, Adams Street and Grant Avenue, Villa Park, Illinois 60681

**LABORATORY:** Prairie Analytical Systems, Inc.

**PROJECT NUMBER:** T116693

**MATRIX:** Soil

**Analytical Method: EPA Method 6010/6020**

Contaminant of Concern	Maximum Allowable Concentration (MAC) within a Metropolitan Statistical Area (MSA)		Sample ID	SB-1	SB-2	SB-3	SB-4	SB-5	SB-6	SB-7	SB-8
			Sample Date	12/5/2016	12/5/2016	12/5/2016	12/5/2016	12/5/2016	12/5/2016	12/5/2016	12/5/2016
			pH	8.1	8.1	8.4	8.6	7.9	7.1	7.7	7.9
			6.25 ≤ pH ≤ 9.0	Yes							
			Depth	6-7.5'	8.5-10'	8.5-10'	3.5-5'	1-2.5'	3.5-5'	8.5-10'	6-7.5'
Value	Objective	Soil Type	Silty Clay	Silty Clay	Silty Clay	Silty Clay	Silty Clay	Silty Clay	Silty Clay	Silty Clay	
Arsenic	<b>13</b>	<b>MAC</b>		7.44	NA	6.91	NA	NA	NA	NA	<b>18.8</b>
Barium	<b>1,500</b>	<b>MAC</b>		32.0	NA	27.2	NA	NA	NA	NA	39.8
Cadmium	<b>5.2</b>	<b>MAC</b>		0.536	NA	0.621	NA	NA	NA	NA	0.581
Chromium	<b>21</b>	<b>MAC</b>		20.2	NA	17.4	NA	NA	NA	NA	19.2
Lead	<b>107</b>	<b>MAC</b>		20.3	NA	12.9	NA	NA	NA	NA	11.7
Mercury	<b>0.89</b>	<b>MAC</b>		< 0.0897	NA	< 0.0866	NA	NA	NA	NA	< 0.0892
Selenium	<b>1.3</b>	<b>MAC</b>		< 0.561	NA	0.563	NA	NA	NA	NA	< 0.557
Silver	<b>4.4</b>	<b>MAC</b>		< 0.561	NA	< 0.541	NA	NA	NA	NA	< 0.557

**Notes:**

Constituents that are not identified in 35 IAC 1100 Subpart F (MAC Table) are compared to the Metropolitan Statistical Area Background Concentration found in 35 IAC 742 Appendix A, Table H

< = Analyte not detected (i.e. less than RL or MDL)

All data reported in milligrams per kilogram (mg/kg) unless otherwise noted.

NA = This constituent was not analyzed.

NE = No remediation objective established by the IEPA for this constituent.

Bold identifies an exceedence of the referenced objective.



TABLE 3 cont.

Summary of Soil Analytical Results - Soil Characterization Sampling

Resource Conservation Recovery Act (RCRA) Metals

CLIENT: Village of Villa Park

SAMPLE DATE: December 5, 2016

SITE: Portions of Harvard Avenue, Ridge Road, Sunset Drive, Adams Street and Grant Avenue, Villa Park, Illinois 60681

LABORATORY: Prairie Analytical Systems, Inc.

PROJECT NUMBER: T116693

MATRIX: Soil

Analytical Method: EPA Method 6010/6020

Contaminant of Concern	Maximum Allowable Concentration (MAC) within a Metropolitan Statistical Area (MSA)		Sample ID	SB-9	SB-8A	SB-8B	SB-9A	SB-9B	SB-9C	SB-9D		
			Sample Date	12/5/2016	2/1/2017	2/1/2017	2/1/2017	2/1/2017	2/1/2017	2/1/2017		
			pH	8.4	-	-	-	-	-	-	-	
			6.25 ≤ pH ≤ 9.0	Yes	-	-	-	-	-	-	-	
			Depth	6-7.5'	6-7.5'	6-7.5'	6-7.5'	6-7.5'	6-7.5'	6-7.5'	6-7.5'	
	Value	Objective	Soil Type	Silty Clay	Silty Clay	Silty Clay	Silty Clay	Silty Clay	Silty Clay	Silty Clay		
Arsenic	<b>13</b>	<b>MAC</b>		<b>27.7</b>	8.40	6.24	<b>13.9</b>	<b>14.5</b>	<b>20.0</b>	8.43		
Barium	<b>1,500</b>	<b>MAC</b>		67.2								
Cadmium	<b>5.2</b>	<b>MAC</b>		1.34								
Chromium	<b>21</b>	<b>MAC</b>		<b>22.2</b>								
Lead	<b>107</b>	<b>MAC</b>		20.4								
Mercury	<b>0.89</b>	<b>MAC</b>		< 0.0946								
Selenium	<b>1.3</b>	<b>MAC</b>		< 0.591								
Silver	<b>4.4</b>	<b>MAC</b>		< 0.591								

Notes:

Constituents that are not identified in 35 IAC 1100 Subpart F (MAC Table) are compared to the Metropolitan Statistical Area Background Concentration found in 35 IAC 742 Appendix A, Table H

< = Analyte not detected (i.e. less than RL or MDL)

All data reported in milligrams per kilogram (mg/kg) unless otherwise noted.

NA = This constituent was not analyzed.

NE = No remediation objective established by the IEPA for this constituent.

Bold identifies an exceedence of the referenced objective.



**TABLE 4**

**Summary of Soil Analytical Results - Soil Characterization Sampling**

**Resource Conservation Recovery Act (RCRA) Metals**

**CLIENT:** Village of Villa Park

**SAMPLE DATE:** December 5, 2016

**SITE:** Portions of Harvard Avenue, Ridge Road, Sunset Drive, Adams Street and Grant Avenue, Villa Park, Illinois 60681

**LABORATORY:** Prairie Analytical Systems, Inc.

**PROJECT NUMBER:** TII6693

**MATRIX:** Soil

**Analytical Method: EPA Method 6020**

Contaminant of Concern	Maximum Allowable Concentration (MAC) within a Metropolitan Statistical Area (MSA)		Sample ID	SB-9							
	Value	Objective	Sample Date	12/5/2016							
			Depth	6-7.5'							
			Soil Type	Silty Clay							
Arsenic	<b>0.05</b>	<b>SCOG</b>		NA							
Barium	<b>2</b>	<b>SCOG</b>		NA							
Cadmium	<b>0.005</b>	<b>SCOG</b>		NA							
Chromium	<b>0.1</b>	<b>SCOG</b>		0.0100							
Lead	<b>0.0075</b>	<b>SCOG</b>		NA							
Mercury	<b>0.002</b>	<b>SCOG</b>		NA							
Selenium	<b>0.05</b>	<b>SCOG</b>		NA							
Silver	<b>0.05</b>	<b>SCOG</b>		NA							

**Notes:**

Constituents that are not identified in 35 IAC 1100 Subpart F (MAC Table) are compared to the Metropolitan Statistical Area Background Concentration found in 35 IAC 742 Appendix A, Table H

As an alternative to the subject maximum allowable concentration value, compliance verification may be determined by comparing soil sample extraction results (TCLP/SPLP) for this constituent to the respective TACO Class I Soil Component of the Groundwater Ingestion Exposure Route objective (35 Ill. Admin. Code 742.Appendix B, Table A). (See 35 IAC 1100.610(b)(1)(B); 1100.610(b)(3)(C)).

< = Analyte not detected (i.e. less than RL or MDL)

All data reported in milligrams per liter (mg/L) unless otherwise noted.

NA = This constituent was not analyzed.

NE = No remediation objective established by the IEPA for this constituent.

Bold identifies an exceedence of the referenced objective.



NOT FOR BID